

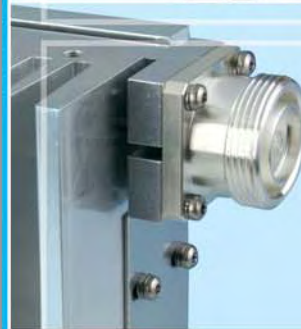

**MOBILFUNK  
KOMponentEN UND SYSTEME**

**MOBILE COMMUNICATION  
COMPONENTS AND SYSTEMS**







Company Profile . . . . . 4

Produktgruppen – Übersicht  
Product Group – Overview . . . . . 7

Koaxiale Steckverbinder – Serie N  
Coaxiale Connectors – Type N . . . . . 8

Koaxiale Steckverbinder – Serie 7-16  
Coaxiale Connectors – Type 7-16 . . . . . 20

Übergangsverbinder  
Inter-Type Adaptors . . . . . 33

Werkzeuge und Zubehör  
Tools and Accessories . . . . . 35

Kalibrierkits  
Calibration Kits . . . . . 36

Konfektionierte Kabel  
Cable Assemblies . . . . . 38

Überspannungsableiter  
Surge Protectors . . . . . 50

Koaxiale Verteiler & Richtkoppler  
Coaxial Splitter & Coupler . . . . . 77

Koaxiale Abschlusswiderstände & Dämpfungsglieder  
Coaxial Loads & Attenuators . . . . . 87

Koaxialer DC-Block  
Coaxial DC Break . . . . . 100

Koaxiale Filter  
Coaxial Filters . . . . . 102

MNCS® – Mobile Network Combining System . . . . . 109

    Diplexer . . . . . 110

    Triplexer . . . . . 120

    Multiplexer . . . . . 122

    Modules . . . . . 136

    Gestelle/Racks . . . . . 147

    Systemlösungen (Referenzen) / System solutions (References) . . . . . 148

Allgemeine technische Informationen  
General Technical Information . . . . . 160

VSWR Umrechnungstabelle  
VSWR Conversion Table . . . . . 163

Index . . . . . 164



### SPINNER SETS STANDARDS IN RF-TECHNOLOGY

Die SPINNER GmbH ist einer der weltweit führenden Hersteller von hochwertigen HF-Komponenten.

Seit über 60 Jahren liefern wir unseren Kunden innovative Produkte sowie kundenspezifische Lösungen für die verschiedensten Anwendungsbereiche.

Mit Hauptsitz in München und Produktionsstätten in Deutschland, Ungarn, China und den USA beschäftigt die SPINNER Gruppe heute mehr als 1.400 Mitarbeiter.

Mit Niederlassungen und Vertretungen in über 40 Ländern bieten wir unseren Kunden weltweit kompetente Unterstützung.

Unser Ziel war und ist es, unsere technische Kompetenz und langjährige Erfahrung zu nutzen, um die besten Lösungen für unsere Kunden zu finden.

#### **Wir sind ihr kompetenter Partner**

für den Mobilfunkmarkt und liefern ein vollständiges Spektrum aller passiven Komponenten zwischen Sendestation und Antenne. Unsere Produkte unterstützen alle modernen Netze, wie TETRA/TETRAPOL, GSM, UMTS, WLAN bis WiMAX. SPINNER Produkte sind bei allen großen Netzbetreibern zugelassen und werden weltweit eingesetzt.

SPINNER ist Marktführer bei koaxialen Steckverbindern der Serien N und 7-16 (DIN) sowie in der Fertigung von konfektionierten Wellrohrkabeln.

Neben einer Vielzahl an Systemkomponenten bieten wir seit einigen Jahren mit unserem Mobile Network Combining System (MNCS®) innovative Lösungen für die Mehrfachnutzung von Antennenanlagen im freien Funkfeld, in Gebäuden sowie für Tunnelfunk.

Die Bereitstellung von hochwertigen HF-Komponenten ist nur möglich, wenn die notwendigen personellen und fertigungstechnischen Voraussetzungen gegeben sind. SPINNER investiert deshalb seit Jahren gezielt in eine hochqualifizierte Weiterbildung seiner Mitarbeiter und modernste Anlagen, Mess- und Prüfgeräte bis in den Sub-Mikrometerbereich, in einen eigens entwickelten Intermodulations-Messplatz für GSM900 und 1800 mit einer Systemempfindlichkeit von -170 dBc, sowie in moderne, umweltschonende Galvanikanlagen.

SPINNER GmbH is one of the leading high-quality RF component and systems manufacturers in the world. For more than 60 years we have been supplying our customers with innovative products and customer specific solutions for a broad range of applications.

The SPINNER Group has its headquarters in Munich, Germany, with production facilities in Germany, Hungary, China and the US that employ more than 1,400 workers world-wide.

We have subsidiaries and representatives in over 40 countries providing the highest level of support to our international customers. It has always been our mission to use our technical expertise and long-standing experience in order to create the optimum solutions for our customers.

#### **We are your competent partner**

for the mobile communication market, supplying all passive components between the transmitter station and the antenna. Our products support all modern networks, such as TETRA/TETRAPOL, GSM, UMTS, WLAN and WiMAX. SPINNER products have been approved by all major network operators and are used world-wide.

SPINNER is the market leader in type N and 7-16 (DIN) connectors, as well as in the manufacture of custom corrugated sheath cables.

In addition to a broad variety of system components we have for a number of years been offering our Mobile Network Combining System (MNCS®), which provides innovative solutions for the sharing of antenna and cable resources in a shared carrier environment in buildings and in tunnel applications.

A company cannot deliver the highest quality RF components unless it has a well-trained staff and cutting-edge production technology. That is why SPINNER has consistently targeted investment in high level training for the staff and the most modern plants. This includes measuring and testing devices including equipment for the sub-micron range. We have also specially developed an intermodulation measurement station for GSM900 and 1800 with a system sensitivity of -170 dBc and have built modern, environmentally friendly electroplating plants.



## SPINNER SETZT MAßSTÄBE IN DER HF-TECHNIK

### SPINNER SETS STANDARDS IN RF-TECHNOLOGY



Mit unseren hocheffektiven Fertigungsanlagen für konfektionierte Kabel können wir mehr als 1 Million Stück pro Jahr in höchster Qualität produzieren.



Our highly efficient customized cable manufacturing plants allow us to produce over one million top quality units per year.

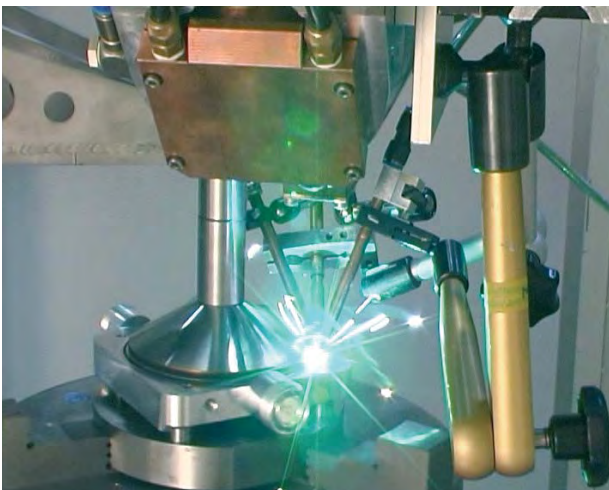

Moderne Laserschweißverfahren ermöglichen den monolithischen Aufbau von Gehäusen. Dieses Verfahren wird unter anderem bei SPINNER Stripline-Diplexern angewendet und sichert damit den Schutzgrad IP68 über die volle Produktlebensdauer.

We use modern laser welding systems in order to create monolithic housing structures. For example, this process is used for the SPINNER stripline diplexer units, to ensure protection rating IP68 over the full product service life.



### **Unser Entwicklungs- und Konstruktionsteam**

wird vom Ziel geleitet, unsere Spitzenposition im Bereich Hochfrequenztechnik aufrechtzuerhalten und ständig auszubauen.

Dem immer schneller voranschreitenden technischen Fortschritt werden wir gerecht, indem wir kontinuierlich an der Optimierung unserer Produkte arbeiten und neue, innovative Lösungen finden. Dafür suchen wir die Kundennähe und die Zusammenarbeit mit renommierten Forschungseinrichtungen. Die konsequente Qualifizierung unserer Mitarbeiter ist ein weiterer Garant für unsere Erfolge.

### **Qualitätsmanagement und Umweltschutz**

bedeutet für SPINNER eine kontinuierliche Verbesserung aller Prozesse im Unternehmen.

Effiziente Abläufe sind Basis und Garant für unsere hohe Produktqualität.

Die gesamte SPINNER Gruppe ist nach DIN EN ISO 9001 zertifiziert. Alle Produkte entsprechen den Richtlinien der RoHS -Verordnung RL 2002/95/EG.

Umweltschutz ist uns Verpflichtung und Herausforderung zugleich. Das Umweltmanagementsystem nach DIN EN ISO 14001 wurde für alle Fertigungsstätten eingeführt und dokumentiert.

Werkstoffe sowie Fertigungsverfahren kommen erst nach sorgfältiger Prüfung zum Einsatz. Wir pflegen die partnerschaftliche Zusammenarbeit mit umweltbewussten Lieferanten und setzen ein zukunftsweisendes Entsorgungssystem nach WEEE RL 2002/96/EG um.

### **Our design and development team**

is guided by the goal to maintain and improve our leading position in the RF technology industry.

As technical progress is moving faster we stay ahead of these developments by our continuous work to improve our products and by creating new and innovative solutions. In this process we work closely with our customers and cooperate with renowned research institutions. Our focus on staff improvement is another driving force of our success.

### **Quality management and environmental protection**

means continuous improvement of all processes within the SPINNER organization.

Efficient processes are the basis that guarantees our high product quality.

The entire SPINNER group is DIN EN ISO 9001 certified. All products meet the RoHS 2002/95/EG guideline.

Environmental protection is an obligation and a challenge for us at the same time. The environmental management system according to DIN EN ISO 14001 has been introduced and documented in all production facilities.

Any materials and production processes can only be used following a careful examination. We rely on partnership in our co-operation with environmentally minded suppliers and use a future-oriented waste disposal system in line with WEEE guideline 2002/96/EG.

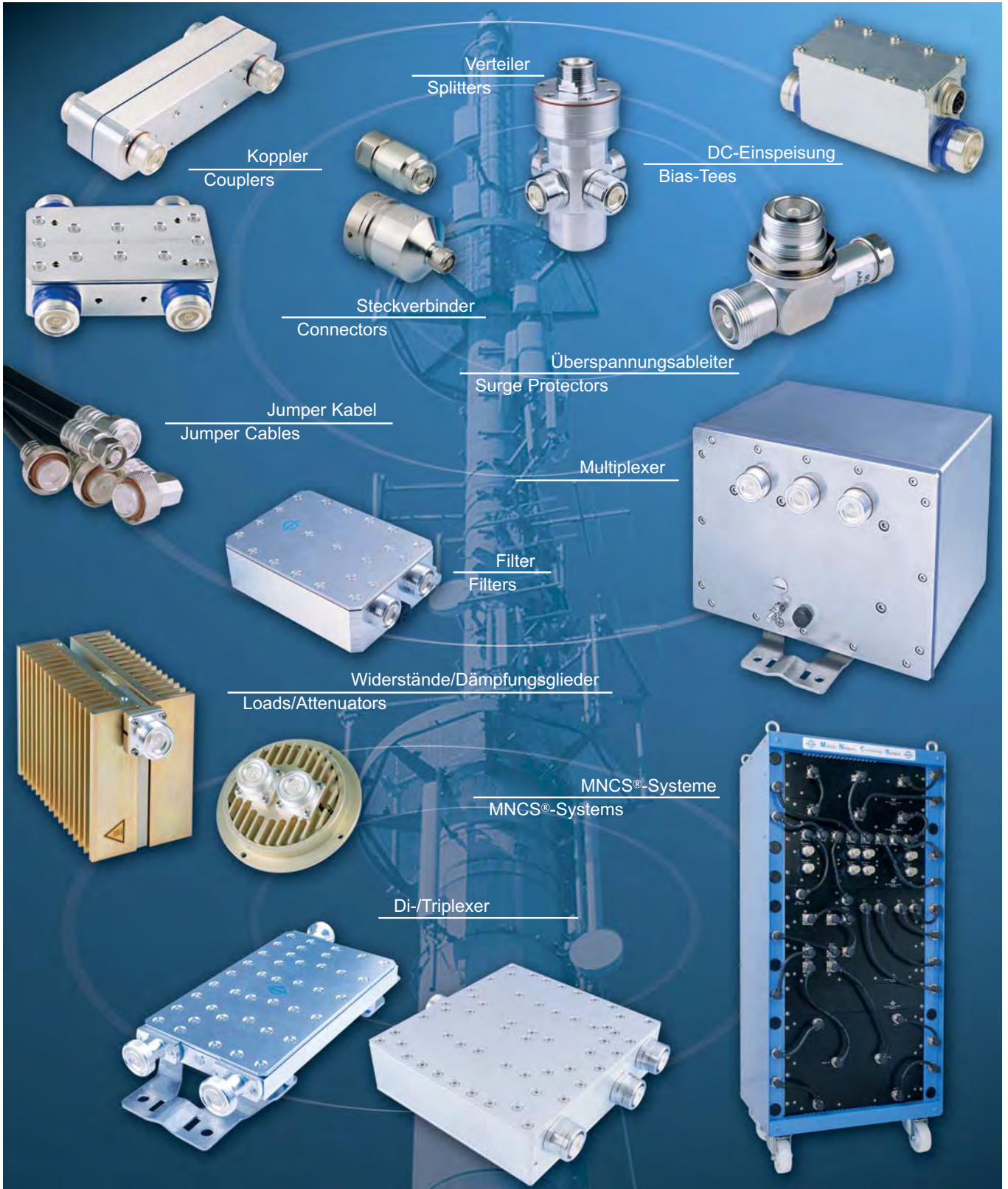

### COAXIAL CONNECTORS – TYPE N



Das Stecksystem N kann bis 11 GHz eingesetzt werden (Präzisionsausführung bis 18 GHz).

Der Einsatz ist vorwiegend in Mobilfunkanwendungen mit hohen mechanischen und elektrischen Anforderungen.

SPINNER liefert aus diesem Grund ausschließlich Steckverbinder mit ungeschlitzter Außenleiterkontakt-hülse und einer speziellen Profildichtung im Stecker-kopf anstelle der nach IEC oder CECC vorgesehenen Flachdichtscheibe, um eine zuverlässige Dichtung sicherzustellen.

Die spezielle SPINNER-Profil Überwurfmutter unserer N-Stecker wird durch Einrollen am Außenleiter fixiert. Hierdurch wird das zulässige Anzugsdrehmoment wesentlich erhöht und der Kontaktdruck deutlich verbessert.

The Type N connector can be used at frequencies up to 11 GHz, high-precision types up to 18 GHz.

It is typically used in mobile communication applications with demanding mechanical and electrical requirements.

That is why SPINNER exclusively manufactures connectors with non-slotted outer conductor contacts and a special sealing profile in the connector head instead of the flat seal disk, specified by IEC or CECC. This ensures the most reliable sealing function.

The coupling nut on N connectors has the special SPINNER profile and is fastened by flanging in the outer conductor. This leads to a much higher tightening torque and unmatched contact pressure.

*Die Steckverbinder der Serie N sind benannt nach Ihrem Erfinder Paul Neill, der diese Norm 1942 entwickelte. Der Name wird allerdings auch häufig aus der Bezeichnung Navy Connector abgeleitet.*

*The N connectors have been named after their inventor, Paul Neill, who developed this standard in 1942. But frequently the name is also related to Navy Connector.*



**COAXIAL CONNECTORS – TYPE N**

Elektrisch / Electrical	IEC 60169-16	IEC	SPINNER	Bemerkung / Remark
Wellenwiderstand Characteristic impedance	10.2	50 Ω		
Frequenzbereich Frequency range	10.2	11 GHz 18 GHz		Stufe / Grade 2 Stufe / Grade 0 +1
VSWR	10.2	≤ 1.30		gerader Steckverbinder bei 11 GHz straight connector at 11 GHz
		≤ 1.50		Winkel-Steckverbinder bei 11 GHz right angle connector at 11 GHz
Innenleiter-Kontaktwiderstand Center contact resistance	10.2	≤ 1 mΩ		anfänglich initial
Außenleiter-Kontaktwiderstand Outer contact resistance	10.2	≤ 0.25 mΩ		anfänglich initial
Isolationswiderstand Insulation resistance	10.2	≥ 5 GΩ		anfänglich initial
Spannungsfestigkeit in Meereshöhe Proof voltage at sea level	10.2	2.5 kV		40...65 Hz
Arbeitsspannung in Meereshöhe Working voltage at sea level	10.2	1.0 kV	1.4 kV	40...65 Hz
Wirksamkeit der Abschirmung Screening effectiveness	10.2	≥ 90 dB	≥ 100 dB	

Mechanisch / Mechanical	IEC 60169-16	IEC	SPINNER	Bemerkung / Remark
Kupplungsdrehmoment Coupling torque	10.2	0.7 ... 1.1 Nm	3.0 Nm	
Prüfdrehmoment Proof torque	10.2	1.7 Nm	4.0 Nm	
Zugfestigkeit des Kupplungsmechanismus Tensile strength of coupling mechanism	10.2	450 N		
Mechanische Lebensdauer Mechanical lifetime	10.2	500	10000	Betätigungen Operations
Fesselung des Innenleiters Center contact captivation				ja yes

Umwelt / Environmental	IEC 60169-16	IEC	SPINNER	Bemerkung / Remark
Klimaklasse / Climatic category	10.2	55/155/21		
Temperaturbereich / Temperature range	10.2	-55 ... +155 °C		
Schutzgrad / Degree of protection		IP68		gesteckt/mated

Werkstoffe und Oberflächenbehandlung / Materials and Surface Finish	
Federnde Kontaktteile Resilient contact members	hochfeste Cu-Legierung, versilbert (MIL-Typen Innenleiter vergoldet) high strength copper alloy, silver plated (MIL-types center conductor gold plated)
Isolation Insulation	PTFE/FEP
Innen- und Außenleiterkontaktteile Center and outer conductor parts	Cu-Legierung, versilbert (bei MIL-Typen Innenleiter vergoldet) Copper alloy, silver plated (with MIL-types center conductor gold plated)
Sonstige Metallteile Other metal parts	Cu-Legierung, glanzvernickelt Copper alloy, bright nickel plated
Dichtungen Gaskets	Silikonkautschuk Silicone rubber

# KOAXIALE STECKVERBINDER – SERIE N



## COAXIAL CONNECTORS – TYPE N

### KABELSTECKVERBINDER FÜR SCF14-50 ■ CABLE CONNECTORS FOR SCF14-50

Ausführung Version	Ω	Bestell-Nummer Part Number
CAF® Schrumpfschlauch CAF® Heat shrink sleeve	50	BN 84 47 60 BN 75 78 60 BN 84 55 60



BN 84 47 60

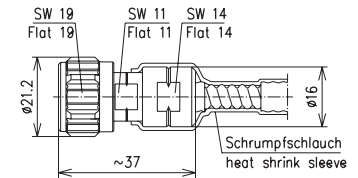

BN 75 78 60

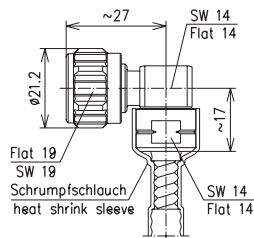

BN 84 55 60

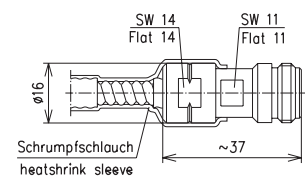

### KABELSTECKVERBINDER FÜR SCF38-50 ■ CABLE CONNECTORS FOR SCF38-50

Ausführung Version	Ω	Bestell-Nummer Part Number
CAF® Profildichtung CAF® Profile gasket	50	BN 87 01 63 BN 87 01 65* BN 87 01 73 BN 84 60 63

\*) Innenleiter vergoldet  
Inner conductor gold plated



BN 87 01 63 / BN 87 01 65\*

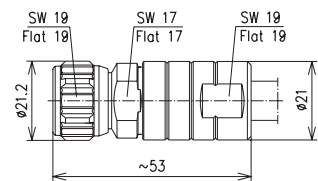

BN 87 01 73\*

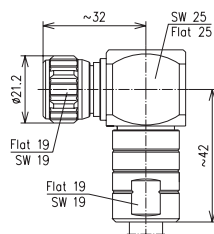

BN 84 60 63

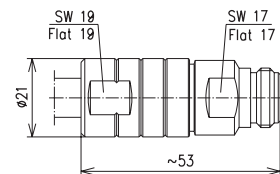

### KABELSTECKVERBINDER FÜR SCF/UCF12-50 ■ CABLE CONNECTORS FOR SCF/UCF12-50

Ausführung Version	$\Omega$	Bestell-Nummer Part Number
CAF® Profildichtung CAF® Profile gasket	50	BN 87 01 57 BN 87 01 56* BN 84 60 57

\*) Innenleiter vergoldet  
Inner conductor gold plated

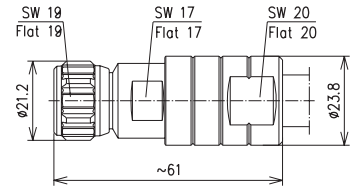

BN 87 01 57



BN 87 01 56\*

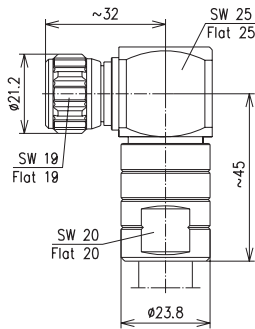

BN 84 60 57

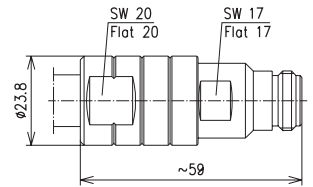

### KABELSTECKVERBINDER FÜR LCF14-50 ■ CABLE CONNECTORS FOR LCF14-50

Ausführung Version	$\Omega$	Bestell-Nummer Part Number
CAF® O-Ring	50	BN 84 47 55 BN 75 78 55 BN 84 55 55 BN 74 76 45



BN 84 47 55

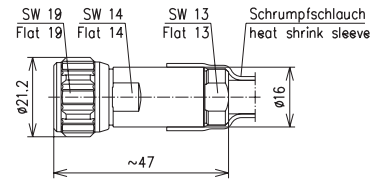

BN 75 78 55

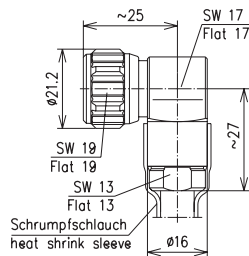

BN 84 55 55

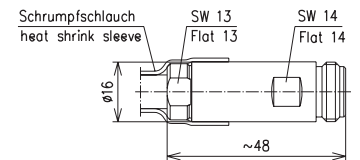

BN 74 76 45

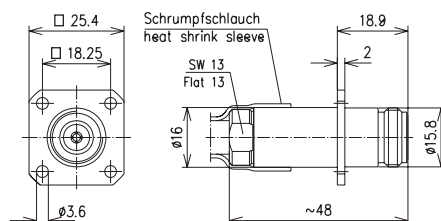

# KOAXIALE STECKVERBINDER – SERIE N



## COAXIAL CONNECTORS – TYPE N

### KABELSTECKVERBINDER FÜR LCF38-50 ■ CABLE CONNECTORS FOR LCF38-50

Ausführung Version	$\Omega$	Bestell-Nummer Part Number
CAF® O-Ring	50	BN 87 01 69
		BN 87 01 70
		BN 84 60 69



BN 87 01 69

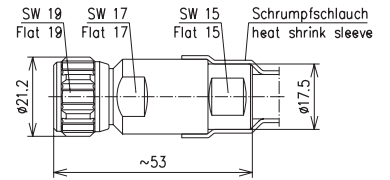

BN 87 01 70

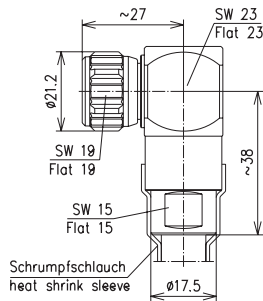

BN 84 60 69

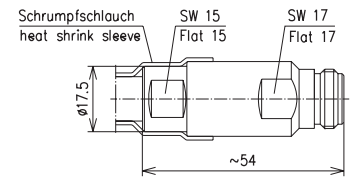

### KABELSTECKVERBINDER FÜR LCF12-50 ■ CABLE CONNECTORS FOR LCF12-50

Ausführung Version	$\Omega$	Bestell-Nummer Part Number
CAF® Plast 2000®	50	BN 87 01 68
CAF® O-Ring	50	BN 87 01 89
CAF® Plast 2000®	50	BN 87 01 67
CAF® O-Ring	50	BN 87 01 87
CAF® Plast 2000®	50	BN 84 60 68
CAF® O-Ring	50	BN 84 60 89
CAF® Plast 2000®	50	BN 74 75 44



BN 87 01 68

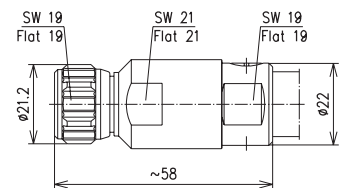

BN 87 01 89

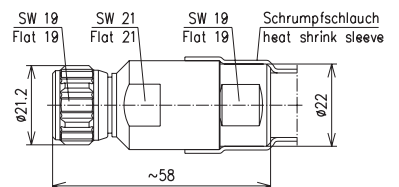

### KABELSTECKVERBINDER FÜR LCF12-50 ■ CABLE CONNECTORS FOR LCF12-50



BN 87 01 67

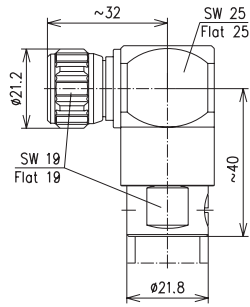

BN 87 01 87

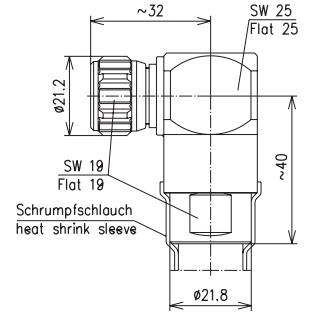

BN 84 60 68

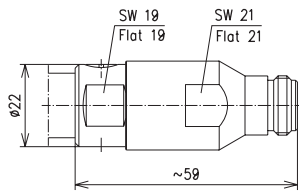

BN 84 60 89

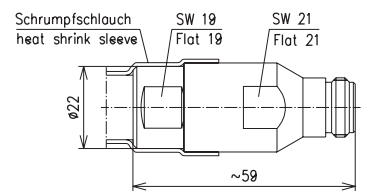

BN 74 75 44

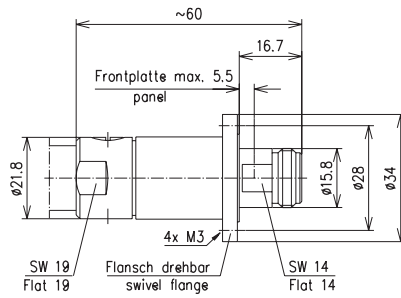

## COAXIAL CONNECTORS – TYPE N

### KABELSTECKVERBINDER FÜR LCF/UCF78-50 ■ CABLE CONNECTORS FOR LCF/UCF78-50

Ausführung Version	$\Omega$	Bestell-Nummer Part Number
CAF® Plast 2000®	50	BN 70 67 40
TOPSPIN® O-Ring	50	BN 70 67 18*
CAF® Plast 2000®	50	BN 84 63 40
TOPSPIN® O-Ring	50	BN 84 63 18*

\*) verwendbar für Al- und Cu-Kabel  
suitable for aluminium and copper cables



BN 70 67 40

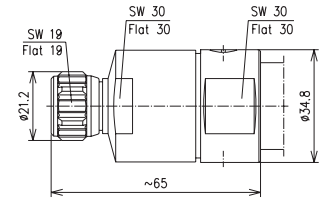

BN 70 67 18\*

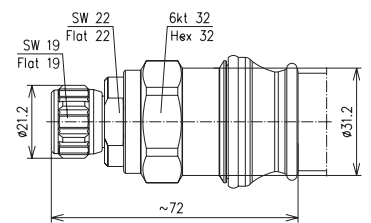

BN 84 63 40

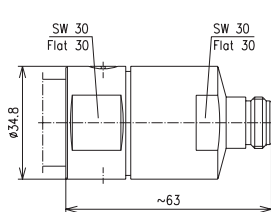

BN 84 63 18\*

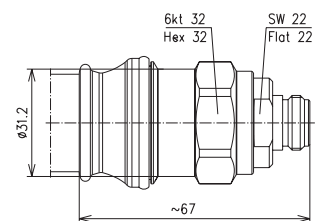

### KABELSTECKVERBINDER FÜR UCF/LCFS114-50 ■ CABLE CONNECTORS FOR UCF/LCFS114-50

Ausführung Version	$\Omega$	Bestell-Nummer Part Number
CAF® Plast 2000®	50	BN 70 67 42
CAF® O-Ring	50	BN 70 67 43
CAF® Plast 2000®	50	BN 84 63 42
CAF® O-Ring	50	BN 84 63 43



BN 70 67 42

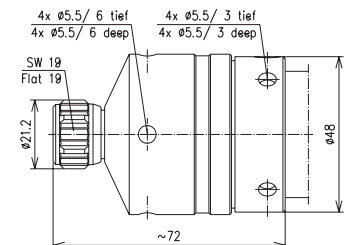

BN 70 67 43

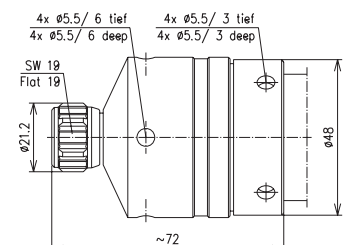

## COAXIAL CONNECTORS – TYPE N

### KABELSTECKVERBINDER FÜR UCF/LCFS114-50 ■ CABLE CONNECTORS FOR UCF/LCFS114-50



BN 84 63 42

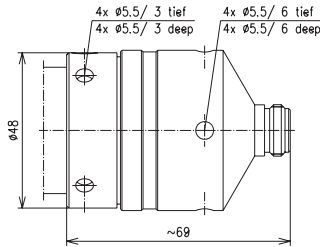

BN 84 63 43

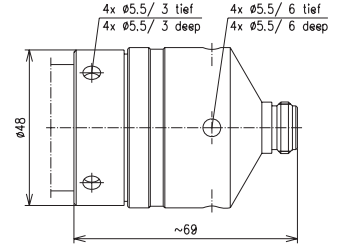

### KABELSTECKVERBINDER FÜR LCF158-50 ■ CABLE CONNECTORS FOR LCF158-50

Ausführung Version	Ω	Bestell-Nummer Part Number
CAF® Plast 2000®	50	BN 70 67 44
TOPSPIN® O-Ring	50	BN 70 67 60*
CAF® Plast 2000®	50	BN 84 63 44
TOPSPIN® O-Ring	50	BN 84 63 60*

\*) verwendbar für Al- und Cu-Kabel  
suitable for aluminium and copper cables



BN 70 67 44

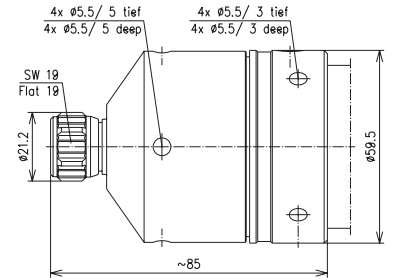

BN 70 67 60\*

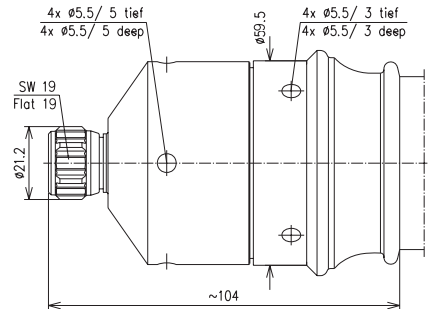

BN 84 63 44

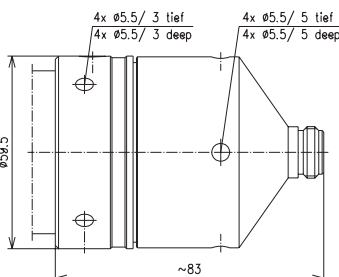

BN 84 63 60\*

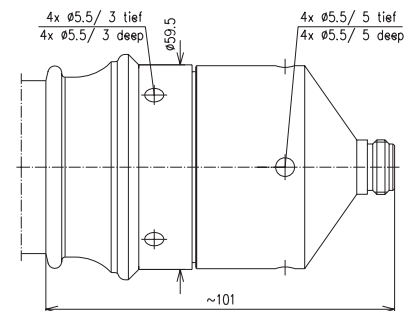

## COAXIAL CONNECTORS – TYPE N

### KABELSTECKVERBINDER FÜR RADIAFLEX® ■ CABLE CONNECTORS FOR RADIAFLEX®

Kabel Typ Cable Type	Ω	Ausführung Version	Bestell-Nummer Part Number
RADIAFLEX® 12-50	50	Schrumpfschlauch Heat shrink sleeve	BN 55 71 10 BN 55 71 11
RADIAFLEX® 58-50 A	50	Schrumpfschlauch Heat shrink sleeve	BN 52 71 91 BN 52 71 92
RADIAFLEX® 78-50	50	Schrumpfschlauch Heat shrink sleeve	BN 55 71 50 BN 55 71 51
RADIAFLEX® 114-50/50 A RADIAFLEX® 158-50/50 A	50	Schrumpfschlauch Heat shrink sleeve	BN 55 71 61 BN 55 71 71

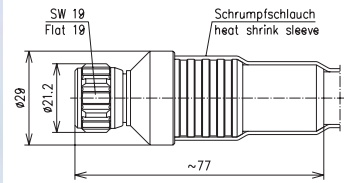

BN 55 71 10

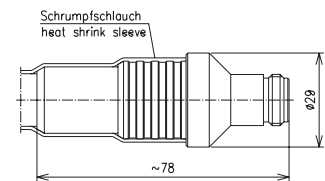

BN 55 71 11

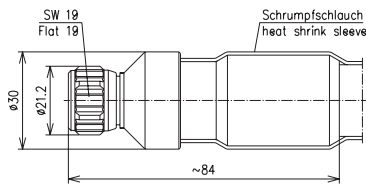

BN 52 71 91

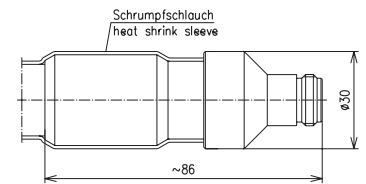

BN 52 71 92

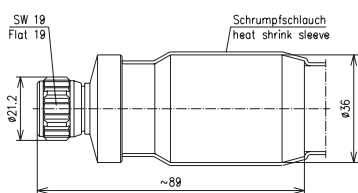

BN 55 71 50

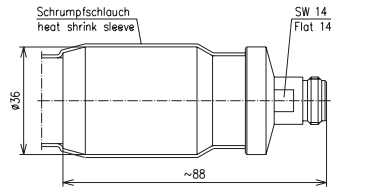

BN 55 71 51

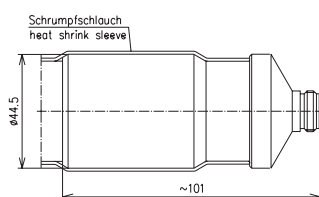

BN 55 71 61

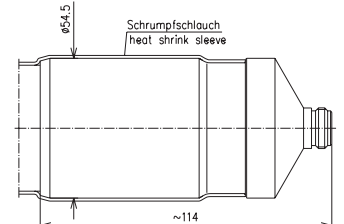

BN 55 71 71



### KABELSTECKVERBINDER FÜR RG-KABEL ■ CABLE CONNECTORS FOR RG-CABLES

Kabel Typ Cable Type	$\Omega$	Ausführung Version	Bestell-Nummer Part Number
RG 58 C/U RG 142 B/U RG 223/U RG 400/U	50	geklemmt clamped	BN 29 66 50 BN 72 12 80
RG 8 Typen (low loss)	50	geklemmt clamped	BN 94 50 60 BN 94 50 61
RG 213/U RG 214/U	50	geklemmt clamped	BN 92 24 50 BN 92 25 50
RG 214/U RG 393/U	50	gecrimpt crimped	BN 92 24 75
RG 214/U RG 393/U	50	geklemmt clamped	BN 72 12 83

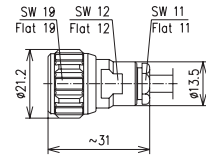

BN 29 66 50

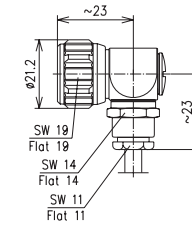

BN 72 12 80

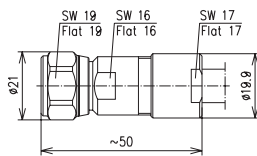

BN 94 50 60

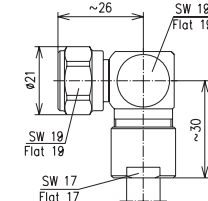

BN 94 50 61

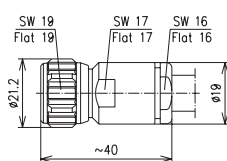

BN 92 24 50

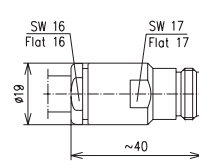

BN 92 25 50

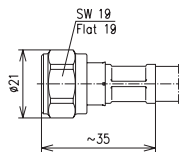

BN 92 24 75

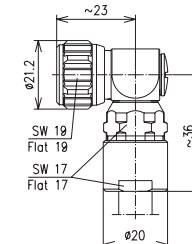

BN 72 12 83

## COAXIAL CONNECTORS – TYPE N

### STECKERKOPF ■ CONNECTOR HEAD

Ausführung Version	Bestell-Nummer Part Number
gerade montierbar im Winkel montierbar straight mounting right angle mounting	BN 45 09 40



BN 45 09 40

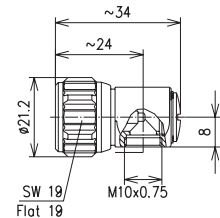

### KABELABFANGUNGEN ■ CABLE ENTRIES

Kabel Typ Cable Type	Ausführung Version	Bestell-Nummer Part Number
RG 55 B/U RG 58 C/U RG 142 B/U RG 223/U RG 400/U	geklemmt clamped	BN 41 94 00
RG 213/U	geklemmt clamped	BN 42 01 00
RG 214/U RG 216/U RG 393/U	geklemmt clamped	BN 98 29 00
RG 214/U RG 393/U	gecrimpt crimped	BN 98 29 11



BN 41 94 00

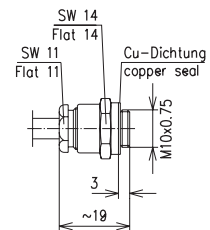

BN 42 01 00

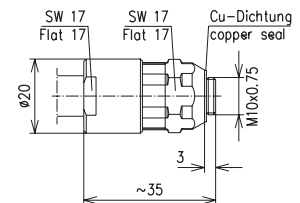

BN 98 29 00

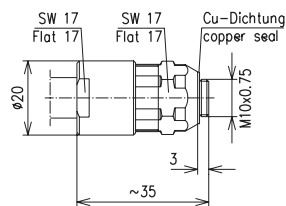

BN 98 29 11

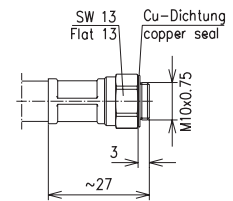

### SCHUTZKAPPEN ■ PROTECTIVE CAPS



BN 99 88 00  
Schutzkappe (Cu-Legierung)  
für Stecker, mit Kette  
Protective cap (copper alloy)  
for plug, with chain

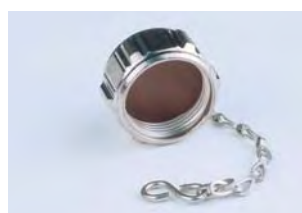

BN 29 63 00  
Schutzkappe (Cu-Legierung)  
für Kuppler, mit Kette  
Protective cap (copper alloy)  
for socket, with chain

## COAXIAL CONNECTORS – TYPE N

### ZWISCHENSTECKVERBINDER ■ WITHIN TYPE ADAPTORS



BN 29 36 50

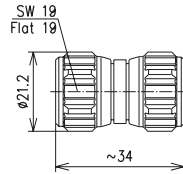

Zwischenstecker  
Adaptor, plug-plug



BN 70 82 50

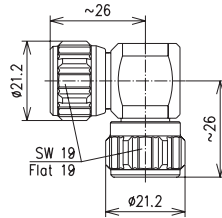

Winkelzwischenstecker  
Right angle adaptor, plug-plug



BN 29 37 50

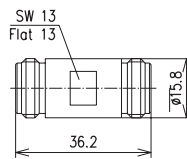

Kupplung  
Adaptor, socket-socket



BN 94 49 50

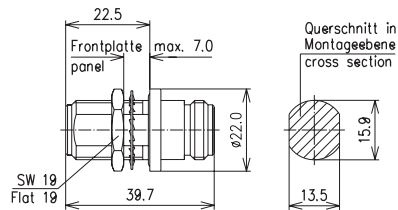

Durchführungskupplung für Einloch-  
montage (einbau- und längsdicht)  
Fixed adaptor, socket-socket,  
for single hole mounting  
(panel and barrier sealed)



BN 94 49 51

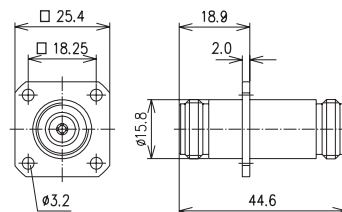

Durchführungskupplung mit Viereckflansch  
Fixed adaptor, socket-socket,  
with four hole mounting flange



BN 29 97 50

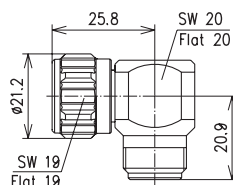

Winkelsteckerkupplung  
Right angle adaptor, plug-socket

### COAXIAL CONNECTORS – TYPE 7-16



Der 7-16 Steckverbinder hat sich durch seine herausragenden mechanischen und elektrischen Eigenschaften zum weltweit am meisten verwendeten koaxialen Stecksystem für Mobilfunk-Sendeanlagen entwickelt.

Um eine optimale Intermodulationsdämpfung von typ. -165 dBc zu erhalten, sind alle Innen- und Außenleiterteile der SPINNER Standardausführung versilbert. Unterstützend werden ausschließlich nicht-magnetische Werkstoffe verwendet und die Anzahl der HF-Kontaktstellen ist minimiert.

Die Steckverbindung ist besonders geeignet für die Übertragung mittlerer und hoher Leistungen, u. a. im Outdoor-Bereich, bis zu einer Frequenz von 8,3 GHz. Wie bei allen anderen SPINNER Steckverbindern sind auch unsere 7-16 Stecker mit der speziellen SPINNER-Profil Überwurfmutter versehen. Diese ermöglicht in Verbindung mit der Befestigung durch Einrollen ein erhöhtes Prüfdrehmoment von bis zu 55 Nm.

The 7-16 connector has become the most widely used coaxial connection system for mobile communication systems, due to its excellent mechanical and electrical properties.

In order to achieve the industry leading intermodulation performance (typically -165 dBc), SPINNER applies silver-plating on all inner and outer conductor parts of the standard connector. As a supporting measure we use exclusively non-magnetic materials, and we have minimized the number of RF contact points.

The connection is especially suited for transmitting medium or high power signals (indoors and outdoors), up to a frequency of 8.3 GHz. Like all other SPINNER connectors our 7-16 connectors are also equipped with the special SPINNER profile coupling nut. This nut, which is fastened by flanging, allows a high test torque up to 55 Nm.

*Die 50  $\Omega$  Steckverbindung 7-16 ist eine Variante des 1954 von Dr. Spinner entwickelten 6-16 Stecksystems (60  $\Omega$ ). Die Bezeichnung ist abgeleitet von den metrischen Abmessungen des Innen- und Außenleiters.*

*The 50  $\Omega$  connector 7-16 is a variant of the connector system 6-16 (60  $\Omega$ ) developed 1954 by Dr. Spinner. The designation is derived from the metric dimensions of the inner and outer conductor.*

**COAXIAL CONNECTORS – TYPE 7-16**

<b>Elektrisch / Electrical</b>	<b>IEC 60169-4</b>	<b>IEC</b>	<b>SPINNER</b>	<b>Bemerkung / Remark</b>
Wellenwiderstand Characteristic impedance		50 Ω		
Frequenzbereich Frequency range	3.	7.5 GHz	8.3 GHz	
VSWR	3.	≤ 1.22		gerader Steckverbinder bis 6 GHz straight connector up to 6 GHz
Innenleiter-Kontaktwiderstand Center contact resistance	9.4.2	≤ 0.4 mΩ		anfänglich initial
Außenleiter-Kontaktwiderstand Outer contact resistance	9.8.2	≤ 0.02 mΩ		anfänglich initial
Isolationswiderstand Insulation resistance	9.1	≥ 10 GΩ		anfänglich initial
Spannungsfestigkeit in Meereshöhe Proof voltage at sea level	9.1	4 kV		50...60 Hz
Arbeitsspannung in Meereshöhe Working voltage at sea level	3.	2.7 kV		50...60 Hz
Wirksamkeit der Abschirmung Screening effectiveness	9.8.2	≥ 128 dB		

<b>Mechanisch / Mechanical</b>	<b>IEC 60169-4</b>	<b>IEC</b>	<b>SPINNER</b>	<b>Bemerkung / Remark</b>
Kupplungsdrehmoment Coupling torque	9.5	25 Nm	25 ... 30 Nm	
Prüfdrehmoment Proof torque		35 Nm	55 Nm	
Zugfestigkeit des Kupplungsmechanismus Tensile strength of coupling mechanism			1000 N	
Mechanische Lebensdauer Mechanical lifetime	9.5	500	10000	Betätigungen Operations
Fesselung des Innenleiters Center contact captivation				ja yes

<b>Umwelt / Environmental</b>	<b>IEC 60169-4</b>	<b>IEC</b>	<b>SPINNER</b>	<b>Bemerkung / Remark</b>
Klimaklasse / Climatic category	4.	55/155/56		
Temperaturbereich / Temperature range	4.	-55 ... +155 °C		
Schutzgrad / Degree of protection		IP68		gesteckt/mated

<b>Werkstoffe und Oberflächenbehandlung / Materials and Surface Finish</b>				
Federnde Kontaktteile Resilient contact members	hochfeste Cu-Legierung, versilbert high strength copper alloy, silver plated			
Isolation Insulation	PTFE/FEP			
Innen- und Außenleiterkontaktteile Center and outer conductor parts	Cu-Legierung, versilbert Copper alloy, silver plated			
Sonstige Metallteile Other metal parts	Cu-Legierung, glanzvernickelt Copper alloy, bright nickel plated			
Dichtungen Gaskets	Silikonkautschuk Silicone rubber			

# KOAXIALE STECKVERBINDER – SERIE 7-16



## COAXIAL CONNECTORS – TYPE 7-16

### KABELSTECKVERBINDER FÜR SCF14-50 ■ CABLE CONNECTOR FOR SCF14-50

Ausführung Version	$\Omega$	Bestell-Nummer Part Number
CAF® Schrumpfschlauch CAF® Heat shrink sleeve	50	BN 74 14 60



BN 74 14 60

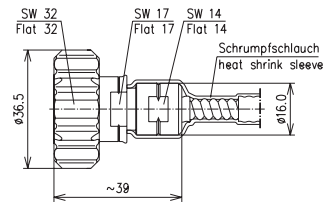

### KABELSTECKVERBINDER FÜR SCF38-50 ■ CABLE CONNECTORS FOR SCF38-50

Ausführung Version	$\Omega$	Bestell-Nummer Part Number
CAF® Profildichtung CAF® Profile gasket	50	BN 84 73 39 BN 84 73 73 BN 71 03 39



BN 84 73 39

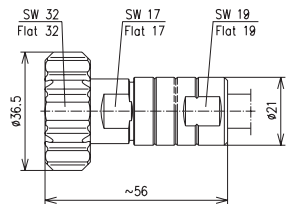

BN 84 73 73

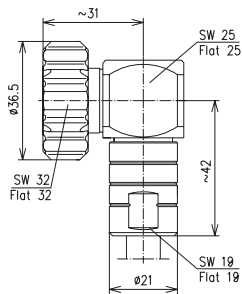

BN 71 03 39

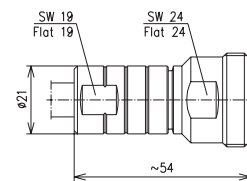

### KABELSTECKVERBINDER FÜR SCF/UCF12-50 ■ CABLE CONNECTORS FOR SCF/UCF12-50

Ausführung Version	$\Omega$	Bestell-Nummer Part Number
CAF® Profildichtung CAF® Profile gasket	50	BN 84 73 59 BN 84 73 57 BN 71 03 59



BN 84 73 59

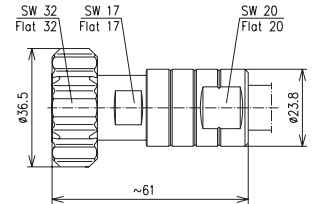

BN 84 73 57

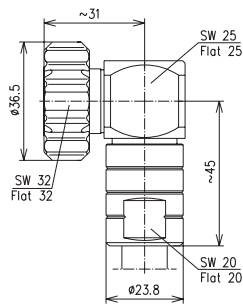

BN 71 03 59

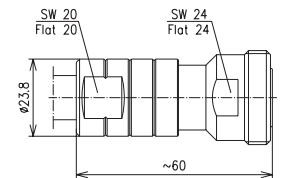

### KABELSTECKVERBINDER FÜR LCF14-50 ■ CABLE CONNECTOR FOR LCF14-50

Ausführung Version	$\Omega$	Bestell-Nummer Part Number
CAF® O-Ring	50	BN 74 14 45



BN 74 14 45

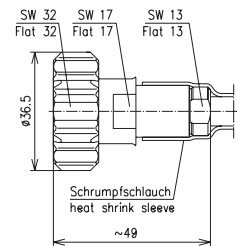

### KABELSTECKVERBINDER FÜR LCF38-50 ■ CABLE CONNECTOR FOR LCF38-50

Ausführung Version	$\Omega$	Bestell-Nummer Part Number
CAF® O-Ring	50	BN 84 73 69



BN 84 73 69

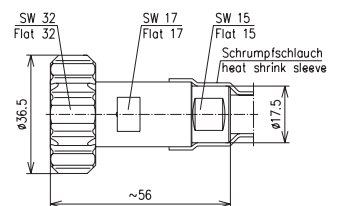

COAXIAL CONNECTORS – TYPE 7-16

KABELSTECKVERBINDER FÜR LCF12-50 ■ CABLE CONNECTORS FOR LCF12-50

Ausführung Version	$\Omega$	Bestell-Nummer Part Number
CAF® Plast 2000®	50	BN 84 73 68
CAF® O-Ring	50	BN 84 73 89
CAF® Plast 2000®	50	BN 84 73 56
CAF® O-Ring	50	BN 84 73 91
CAF® Plast 2000®	50	BN 71 03 68
CAF® O-Ring	50	BN 71 03 89



BN 84 73 68

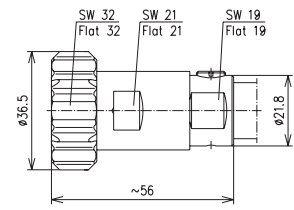

BN 84 73 89

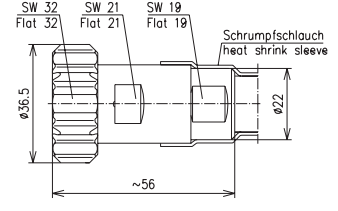

BN 84 73 56

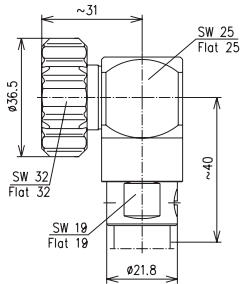

BN 84 73 91

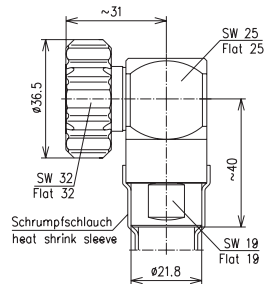

BN 71 03 68

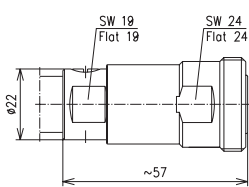

BN 71 03 89

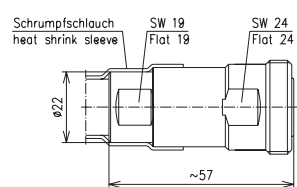



### KABELSTECKVERBINDER FÜR LCF/UCF78-50 ■ CABLE CONNECTORS FOR LCF/UCF78-50

Ausführung Version	$\Omega$	Bestell-Nummer Part Number
CAF® Plast 2000®	50	BN 84 48 40
TOPSPIN® O-Ring	50	BN 85 43 18*
CAF® Plast 2000®	50	BN 84 48 50
CAF® O-Ring	50	BN 84 48 51
CAF® Plast 2000®	50	BN 65 56 40
TOPSPIN® O-Ring	50	BN 65 43 18*

\*) verwendbar für Al- und Cu-Kabel  
suitable for aluminium and copper cables



BN 84 48 40

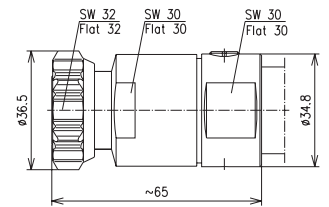

BN 85 43 18\*

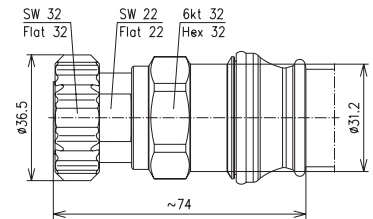

BN 84 48 50

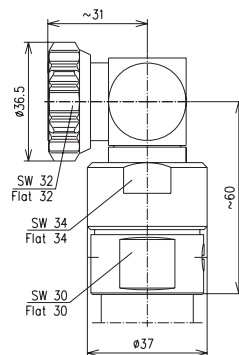

BN 84 48 51

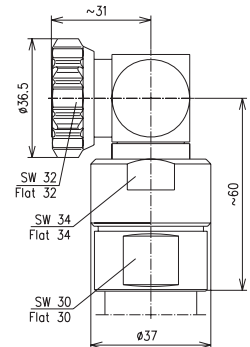

BN 65 56 40

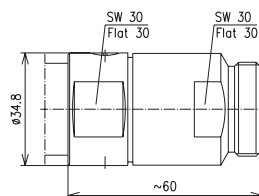

BN 65 43 18\*

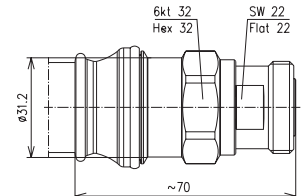

## COAXIAL CONNECTORS – TYPE 7-16

### KABELSTECKVERBINDER FÜR UCF/LCFS114-50 ■ CABLE CONNECTORS FOR UCF/LCFS114-50

Ausführung Version	$\Omega$	Bestell-Nummer Part Number
CAF® Plast 2000®	50	BN 84 48 42
CAF® O-Ring	50	BN 84 48 43
CAF® Plast 2000®	50	BN 65 56 42
CAF® O-Ring	50	BN 65 56 43



BN 84 48 42

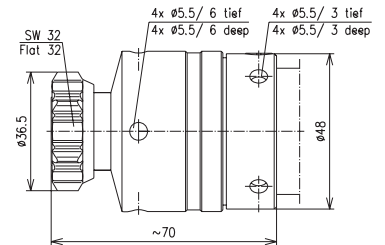

BN 84 48 43

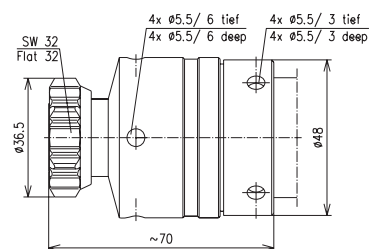

BN 65 56 42

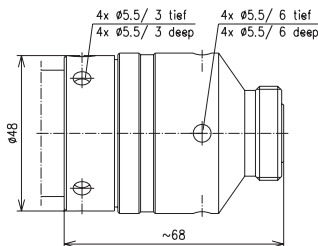

BN 65 56 43

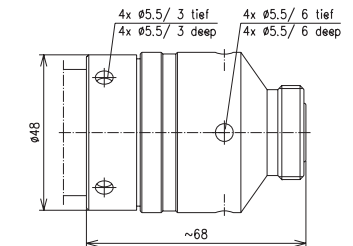

### KABELSTECKVERBINDER FÜR LCF158-50 ■ CABLE CONNECTORS FOR LCF158-50

Ausführung Version	$\Omega$	Bestell-Nummer Part Number
CAF® Plast 2000®	50	BN 84 48 44
TOPSPIN® O-Ring	50	BN 84 48 60*
CAF® Plast 2000®	50	BN 65 56 44
TOPSPIN® O-Ring	50	BN 65 56 60*



BN 84 48 44

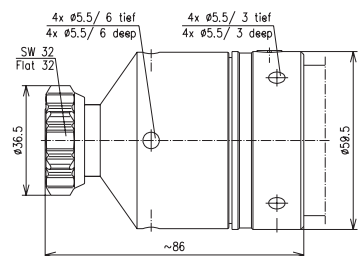

BN 84 48 60\*

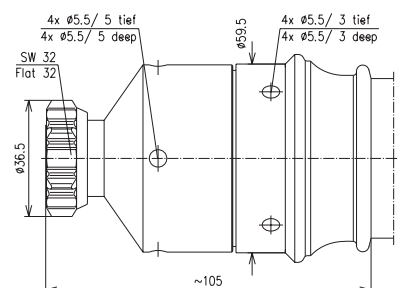

\*) verwendbar für Al- und Cu-Kabel  
suitable for aluminium and copper cables

### KABELSTECKVERBINDER FÜR LCF158-50 ■ CABLE CONNECTORS FOR LCF158-50



BN 65 56 44

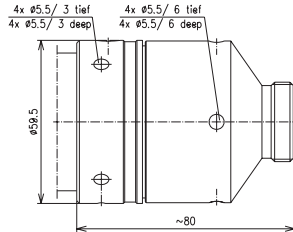

BN 65 56 60\*

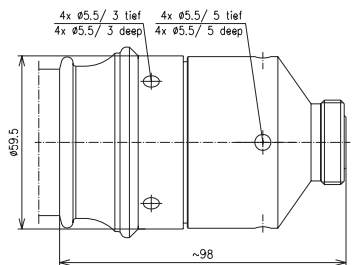

### KABELSTECKVERBINDER FÜR LCF214-50 ■ CABLE CONNECTORS FOR LCF214-50

Ausführung Version	Ω	Bestell-Nummer Part Number
CAF® Plast 2000®	50	BN 84 48 73
CAF® O-Ring	50	BN 84 48 63
CAF® Plast 2000®	50	BN 65 56 73
CAF® O-Ring	50	BN 65 56 63



BN 84 48 73

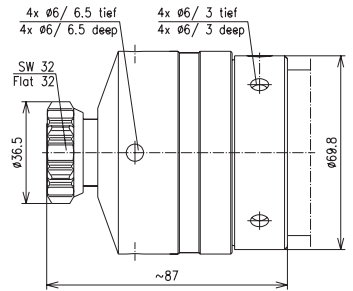

BN 84 48 63

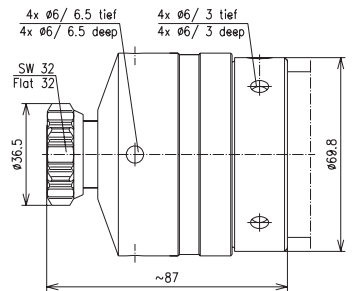

BN 65 56 73

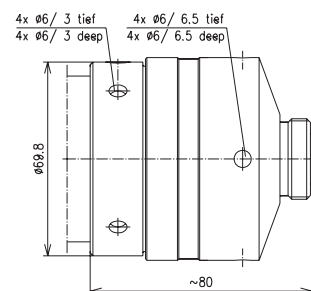

BN 65 56 63

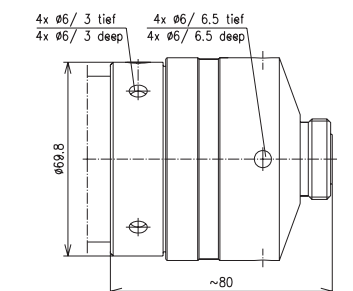

# KOAXIALE STECKVERBINDER – SERIE 7-16



## COAXIAL CONNECTORS – TYPE 7-16

### KABELSTECKVERBINDER FÜR RADIAFLEX® ■ CABLE CONNECTORS FOR RADIAFLEX®

Kabel Typ Cable Type	Ω	Ausführung Version	Bestell-Nummer Part Number
RADIAFLEX® 78-50	50	Schrumpfschlauch Heat shrink sleeve	BN 55 71 52 BN 55 71 53
RADIAFLEX® 114-50	50	Schrumpfschlauch Heat shrink sleeve	BN 55 71 63
RADIAFLEX® 158-50	50	Schrumpfschlauch Heat shrink sleeve	BN 55 71 73



BN 55 71 52

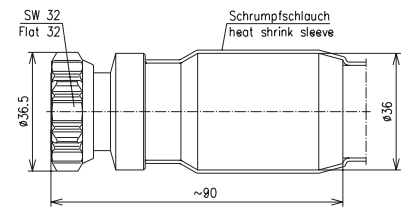

BN 55 71 53

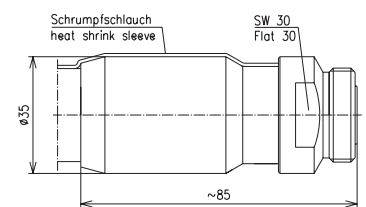

BN 55 71 63

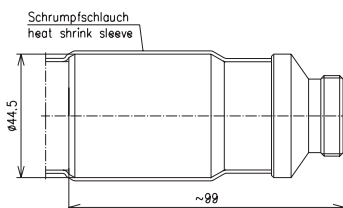

BN 55 71 73

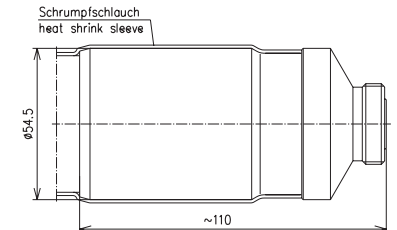

### KABELSTECKVERBINDER FÜR RG-KABEL ■ CABLE CONNECTORS FOR RG-CABLES

Kabel Typ Cable Type	Ω	Ausführung Version	Bestell-Nummer Part Number
RG 402/U	50	gelötet soldered	BN 80 76 25
RG 402/U Semirigid flexible 141	50	gelötet soldered	BN 80 77 88 BN 80 77 06 BN 80 77 50
RG 401/U Semirigid flexible 250	50	gelötet soldered	BN 80 76 21
RG 401/U	50	gelötet soldered	BN 80 77 33 BN 80 77 60
RG 214/U RG 393/U	50	geklemmt clamped	BN 95 18 20 BN 80 76 80 BN 95 19 20



BN 80 76 25

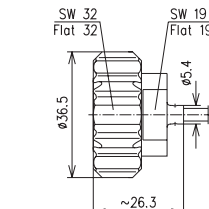

BN 80 77 88

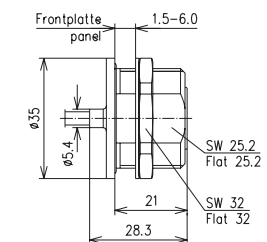

## COAXIAL CONNECTORS – TYPE 7-16

### KABELSTECKVERBINDER FÜR RG-KABEL ■ CABLE CONNECTORS FOR RG-CABLES



BN 80 77 06

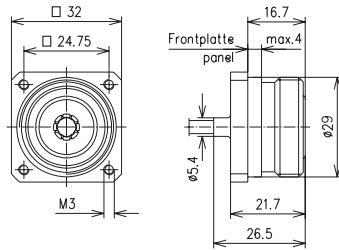

BN 80 77 50

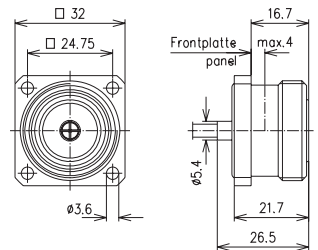

BN 80 76 21

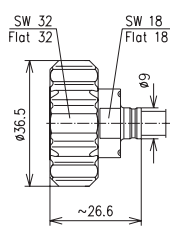

BN 80 77 33

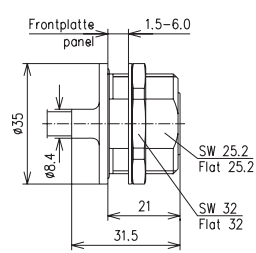

BN 80 77 60

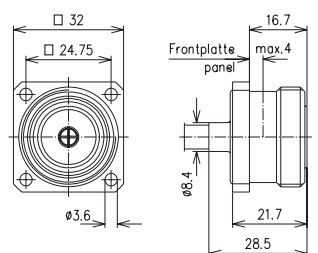

BN 95 18 20

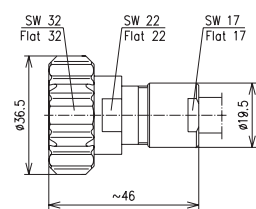

BN 80 76 80

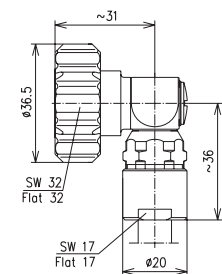

BN 95 19 20

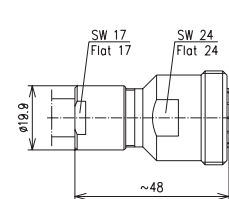

## COAXIAL CONNECTORS – TYPE 7-16

### STECKERKOPF ■ CONNECTOR HEAD

Ausführung Version	Bestell-Nummer Part Number
gerade montierbar im Winkel montierbar straight mounting right angle mounting	BN 45 09 95



BN 45 09 95

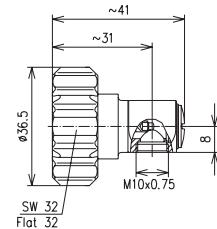

### KABELABFANGUNGEN ■ CABLE ENTRIES

Kabel Typ Cable Type	Ausführung Version	Bestell-Nummer Part Number
RG 55 B/U RG 58 C/U RG 142 B/U RG 223/U RG 400/U	geklemmt clamped	BN 41 94 00
RG 213/U	geklemmt clamped	BN 42 01 00
RG 214/U RG 216/U RG 393/U	geklemmt clamped	BN 98 29 00
RG 214/U RG 393/U	gecrimpt crimped	BN 98 29 11



BN 41 94 00

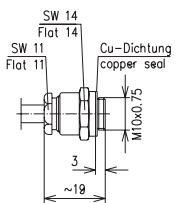

BN 42 01 00

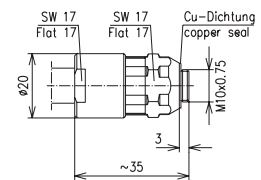

BN 98 29 00

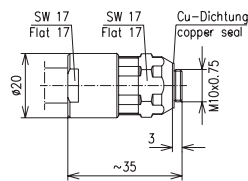

BN 98 29 11

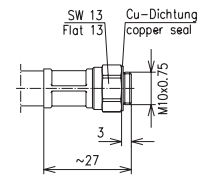

### SCHUTZKAPPEN ■ PROTECTIVE CAPS



BN 23 90 02  
Schutzkappe (Cu-Legierung)  
für Stecker, mit Kette  
Protective cap (copper alloy)  
for plugs with chain



BN 23 89 50  
Schutzkappe (Cu-Legierung)  
für Kuppler, mit Kette  
Protective cap (copper alloy)  
for sockets with chain

## COAXIAL CONNECTORS – TYPE 7-16

### GEHÄUSESTECKVERBINDER ■ FIXED CONNECTORS



BN 95 47 16

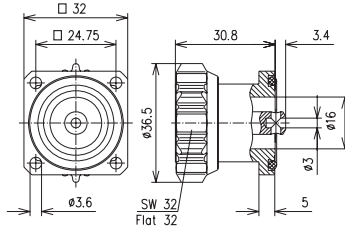

Gehäusestecker mit Viereckflansch  
Abdichtung zum Gehäuse mit O-Ring,  
Innenleiter mit Lötanschluss  
Fixed plug with four hole mounting flange,  
sealing to the panel with O-Ring,  
inner conductor with soldering connection



BN 95 47 65

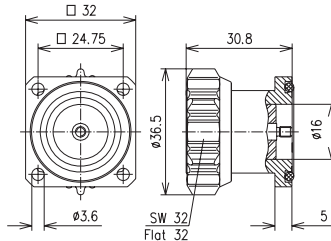

Gehäusestecker mit Viereckflansch  
Abdichtung zum Gehäuse mit O-Ring,  
Innenleiter mit Außengewinde M3  
Fixed plug with four hole mounting flange,  
sealing to the panel with O-Ring,  
inner conductor with M3 male thread



BN 95 45 10

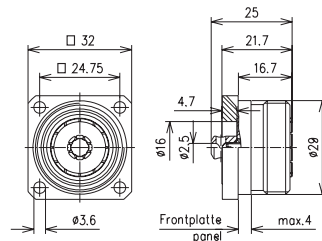

Gehäusekuppler mit Viereckflansch,  
mit Innenleiter-Lötanschluss  
(Außenleiterkontaktbuchse geschlitzt)  
Fixed socket with four hole mounting flange,  
with inner conductor soldering connection  
(with slotted outer conductor)

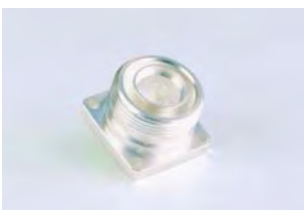

BN 95 46 84

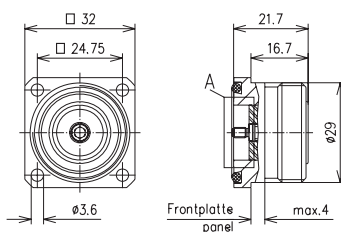

Gehäusekuppler mit Viereckflansch  
Abdichtung zum Gehäuse mit O-Ring,  
Innenleiter verdrehungsgesichert  
mit Außengewinde M3  
Fixed socket with four hole mounting flange,  
sealing to the panel with O-Ring,  
captivated inner conductor with M3 male thread

COAXIAL CONNECTORS – TYPE 7-16

ZWISCHENSTECKVERBINDER ■ WITHIN TYPE ADAPTORS

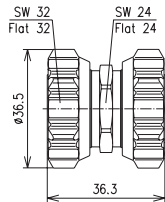

BN 39 33 70  
Zwischenstecker  
Adaptor, plug-plug

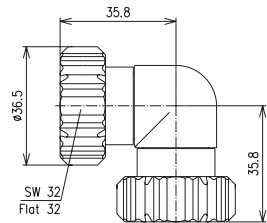

BN 94 47 02  
Winkelzwischenstecker  
Right angle adaptor, plug-plug

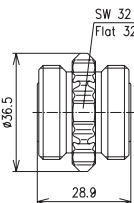

BN 19 64 00  
Kupplung  
Adaptor, socket-socket

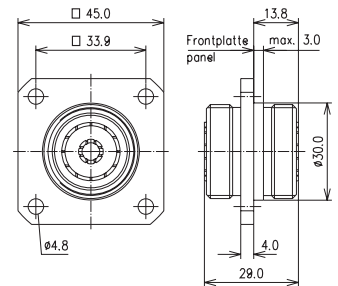

BN 80 84 00  
Durchführungskupplung mit Viereckflansch  
Fixed adaptor, socket-socket  
with four hole mounting flange

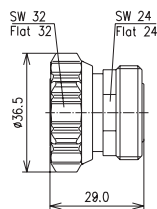

BN 75 64 04  
Steckerkupplung  
(Schutz für Messanschluss)  
Adaptor, plug-socket  
(port saver)

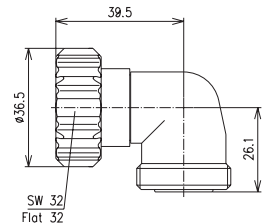

BN 29 64 00  
Winkelsteckerkupplung  
Right angle adaptor, plug-socket

KURZSCHLÜSSE ■ SHORT CIRCUIT

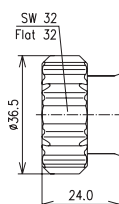

BN 80 64 00  
Kurzschluss, Stecker  
Short circuit, plug

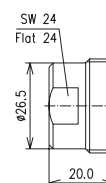

BN 80 65 00  
Kurzschluss, Kuppler  
Short circuit, socket



## INTER-TYPE ADAPTORS



Übergangsverbinder dienen zur Verbindung von Koaxanschlüssen unterschiedlicher Steckverbinder-systeme.

Die in diesem Katalog enthaltenen Bestell-Nummern (BN...) geben die häufigsten und wichtigsten Kombinationen im Mobilfunkbereich an. Nicht enthaltene Kombinationen sind auf Anfrage lieferbar.

Die Angabe Stecker oder Kuppler bezeichnet die jeweilige Ausführung der Anschlüsse des Übergangs-verbinders.

Grundsätzlich werden Übergangsverbinder mit möglichst niedrigen Reflexionsfaktoren entwickelt. Präzisions-Übergangsverbinder der HF-Qualitätsstufe 0 können auf Anfrage geliefert werden.

Inter-type adaptors are used to link up one connector type to another type.

The part numbers (BN...) listed in this catalog include the most common and important combinations for mobile communication systems.

Combinations not listed here are available upon request. We specify the items as either plug (male) or socket (female) in order to describe the connector style of the inter-type adaptor.

Our inter-type adaptors are designed for the lowest possible reflection factors.

Precision inter-type adaptors with RF quality grade 0 are available upon request.

## INTER-TYPE ADAPTORS

Anschluss 1 Connector 1 N	Anschluss 2 Connector 2 TNC	Bestell-Nummer Part Number
Stecker / plug	Kuppler / socket	BN 72 58 10
Kuppler / socket	Stecker / plug	BN 72 59 10
Kuppler / socket	Kuppler / socket	BN 72 60 10



BN 72 58 10

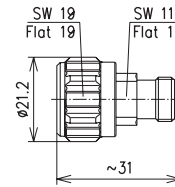

BN 72 59 10

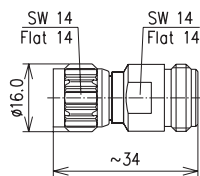

BN 72 60 10

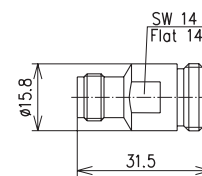

Anschluss 1 Connector 1 7-16	Anschluss 2 Connector 2 N	Bestell-Nummer Part Number
Stecker / plug	Stecker / plug	BN 29 38 00
Stecker / plug	Kuppler / socket	BN 19 44 00
Kuppler / socket	Stecker / plug	BN 29 39 00
Kuppler / socket	Kuppler / socket	BN 29 40 00



BN 29 38 00

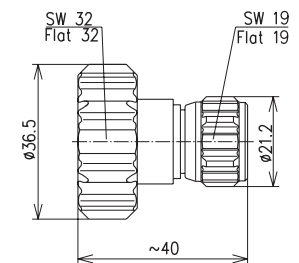

BN 19 44 00

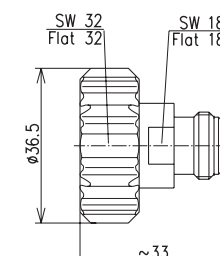

BN 29 39 00

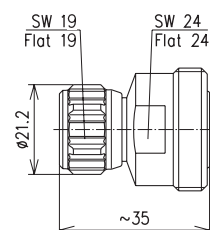

BN 29 40 00

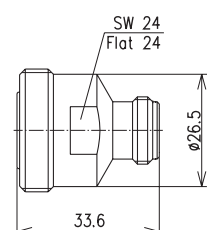

**PLAST 2000®**

Kabeltyp Cable Type	Füllmenge* Filling quantity*
LCF12-50	4 cm <sup>3</sup>
LCF58-50	6 cm <sup>3</sup>
LCF78-50	7 cm <sup>3</sup>
UCF/LCFS114-50	15 cm <sup>3</sup>
LCF158-50	20 cm <sup>3</sup>
LCF214-50	28 cm <sup>3</sup>

Bauteil Part	Bestell-Nummer Part Number
20 cm <sup>3</sup> Tube	BN 15 16 71
70 cm <sup>3</sup> Tube	BN 15 05 97
Einspritzpresse mit Gewinde M9 Injection gun with M9 thread	BN 07 05 51



\* je Steckverbinder Ausführung PLAST® 2000  
per connector in PLAST® 2000 version

- Garantiert eine absolut einwandfreie Abdichtung zwischen Steckverbinder und Kabel
  - Optimaler Korrosionsschutz der Außenleiterkontaktstelle zwischen Kabel und Steckverbinder
  - 20 cm<sup>3</sup> Tube kann direkt in die Kabelabfangung eingeschraubt werden
  - Bei Verwendung der 70 cm<sup>3</sup> Tube ist die Einspritzpresse BN 07 05 51 erforderlich
- guarantees an absolutely perfect sealing function between connector and cable
  - optimum corrosion protection of the outer conductor contact zone between cable and connector
  - the 20 cm<sup>3</sup> tube can be screwed directly into the cable entries
  - for 70 cm<sup>3</sup> tubes injection gun BN 07 05 51 is required

**ABSETZWERKZEUGE ■ TRIMMING TOOLS**

Kabeltyp Cable Type	Bestell-Nummer Part Number
SCF14-50	BN 54 13 28
SCF38-50	BN 54 13 35
SCF/UCF12-50	BN 54 13 34
LCF14-50	BN 54 13 20
LCF38-50	BN 54 13 38
LCF12-50	BN 54 13 17
LCF/UCF78-50	BN 54 13 18
LCF/UCF78-50A/L	BN 54 13 88*
LCFS/UCF114-50A LCF158-50A RADIAFLEX® 114-50 RADIAFLEX® 114-75 RADIAFLEX® 158-50	BN 54 13 36**
UCF114-50A LCF158-50A LCF214-50A	BN 54 13 43***

- für Kupfer- und Aluminium-Wellrohrkabel
- Reduzierung der Montagezeiten um über 60%
- erhebliche Senkung der Montagekosten
- gleichbleibende Montagequalität

- for copper and aluminium corrugated cables
- assembly time cut by more than 60%
- considerable reduction of assembly costs
- constant assembly quality



\* nur für TOPSPIN® Steckverbinder / only for TOPSPIN® connectors

\*\* Komfortausführung mit Kurbel / comfort type with crank

\*\*\* einfache Ausführung mit Kurbel / economy type with crank

## CALIBRATION KITS

Die Kombination aller Ausführungen von Kalibriernormalen zu einer kompakten Einheit ist die optimale Lösung zur einfachen Handhabung bei der Kalibrierung von vektoriellen Netzwerkanalysatoren.

Unsere OSLT-Kombinationen bestehen aus jeweils einem Leerlauf (Open), einem Kurzschluss (Short), einem Abschlusswiderstand (Load) und einer Durchgangsleitung (Through) in einem Bauteil. Jedes Kalibriernormal ist einzeln austauschbar.

Mit einem Einsatzbereich bis zu einer max. Frequenz von 8 GHz können die Kalibriernormale für alle gängigen Mobilfunk-, WLAN- und WiMAX-Anwendungen verwendet werden. Kalibriersätze N und 7-16 vom Typ OSL sind auf Anfrage lieferbar.

Combining all versions of calibration standards to make one compact unit is the optimum solution for easier calibration work on vector network analyzers.

Our OSLT combination systems are one unit, combining an Open, a Short, a Load and a Through standard, all in one. Every calibration standard can be replaced individually.

The maximum frequency of 8 GHz allows you to use these calibration standards for all common mobile communication, WLAN and WiMAX applications.

Calibration sets N and 7-16 of type OSL are deliverable upon request.

Bestell-Nummer Part Number		BN 53 38 43	BN 53 38 44	BN 53 38 45	BN 53 38 46
Anschlüsse (50 Ω) Connectors CECC22190		N Kuppler N socket	N Stecker N plug	7-16 Kuppler 7-16 socket	7-16 Stecker 7-16 plug
Frequenzbereich Frequency range		0 ... 8 GHz		0 ... 6 GHz	
Gewicht Weight		ca./approx. 250 g		ca./approx. 950 g	
Temperaturbereich Temperature range		+ 15 °C ... + 30 °C		+ 15 °C ... + 30 °C	
Schutzgrad Degree of protection		IP40		IP40	
Leerlauf Open	Phasenfehler Phase error	≤ 3°		≤ 1.5°	
Kurzschluss Short	Phasenfehler Phase error	≤ 1.25°		≤ 1.0°	
Abschlusswiderstand / Load					
DC-Widerstand DC resistance		50 ± 0.5 Ω		50 ± 0.5 Ω	
Rückflussdämpfung Return loss		≥ 34 dB		≥ 40 dB	
Anschlussleistung Power rating		≤ 0.5 W		≤ 0.5 W	
Durchgangsleitung / Through					
Rückflussdämpfung Return loss		≥ 31 dB		≥ 34 dB	
Durchgangsdämpfung Insertion loss		≤ 0.1 dB		≤ 0.1 dB	

CALIBRATION KITS



BN 53 38 43

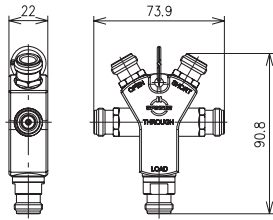

BN 53 38 44

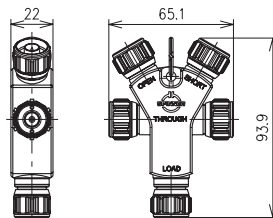

BN 53 38 45

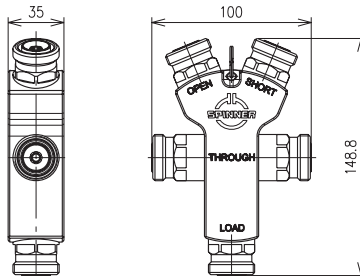

BN 53 38 46

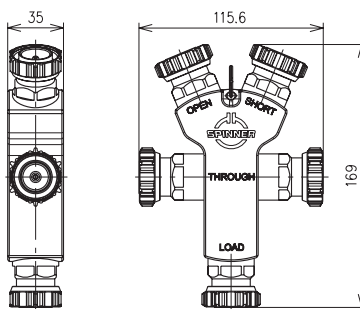

### CABLE ASSEMBLIES



SPINNER fertigt seit Jahren qualitativ hochwertige Jumper Kabel für den Mobilfunkbereich.

Durch unsere vollautomatisierten Fertigungsprozesse bieten wir Ihnen attraktive Preise bei kurzer Lieferzeit. Eine Tageskapazität bis zu 5.000 Stück ermöglicht uns die Produktion von mehr als 1 Million Kabeln pro Jahr in höchster Qualität.

Wir garantieren hervorragende IM-Eigenschaften und niedrige VSWR Werte über die komplette Einsatzdauer der Kabel.

Jumper mit Cu-Wellrohrkabel fertigen wir in den Kabelgrößen 1/4", 3/8" und 1/2" mit allen gängigen Mobilfunksteckverbindern. Innen- und Außenleiter werden 360° induktiv verlötet, der Schutzgrad IP68 nach IEC 60529 wird garantiert.

Selbstverständlich erfüllen alle unsere Wellrohr Jumper die RoHS 2002/95 Richtlinien.

Auf Wunsch konfektionieren wir für Sie Jumper Kabel mit speziellen Anforderungen, wie z. B. Phasenabgleich mit sehr engen Toleranzen, Kabel mit Graumantel oder auch Kabel mit zusätzlichem Schutzschlauch.

Spinner has long-standing experience in manufacturing high-quality jumper cables for mobile communication applications. Our fully automated manufacturing processes offer you the benefits of competitive prices and short lead times. Our daily capacity is 5,000 pieces, allowing us to produce more than one million top quality cables assemblies per year.

We guarantee superior IM properties and low VSWR values over the complete service life of the cables.

We manufacture jumpers with Cu corrugated sheath cables in sizes 1/4", 3/8" and 1/2" with all common mobile communication connector types. The inner and outer conductors are 360° induction-brazed, which guarantees an IP68 protection rating under IEC standard 60529. Our corrugated sheath jumpers all meet the RoHS 2002/95 guidelines.

Upon request we also customize jumper cables to meet your specific requirements, such as phase adjustment with extremely narrow tolerances, cables with grey sheath or cables with an additional protection sheath.

Für Ihre Bestellung nennen Sie uns einfach die benötigten Steckverbinder-Kombinationen und Kabellängen.

Innerhalb von 24 Stunden erhalten Sie dann die Auftragsbestätigung von uns.

All you need to do to order a jumper cable assembly is to tell us the required connector combinations and cable lengths.

Within 24 hours you will receive our order confirmation.

**JUMPER SUPERFLEXIBLE 1/2"**

Wellenwiderstand Impedance	50 Ω				
Intermodulation (IM3) 2 x 20 W f <sub>1</sub> = 1770 MHz; f <sub>2</sub> = 1810 MHz; f <sub>IM3</sub> = 1850 MHz	≤ -160 dBC; typ. -165 dBC				
VSWR* für Stecksysteme 7-16 und N VSWR* for connector sizes 7-16 and N	≤ 1000 MHz	≤ 2200 MHz	≤ 2700 MHz	≤ 3800 MHz	≤ 5825 MHz
Kabel mit 2 geraden Steckverbindern Cable with 2 straight connectors	≤ 1.03	≤ 1.05	≤ 1.06	≤ 1.08	≤ 1.10
Kabel mit 1 geraden und 1 Winkelstecker Cable with 1 straight and 1 right angle connector	≤ 1.04	≤ 1.06	≤ 1.07	≤ 1.09	≤ 1.11
Kabel mit 2 Winkelsteckverbindern Cable with 2 right angle connectors	≤ 1.05	≤ 1.07	≤ 1.08	≤ 1.10	≤ 1.12

\* typische VSWR Werte für Längen ≤ 5 m ; \* typical VSWR values for lengths ≤ 5 m

Kabeltyp Cable Type	max. Dämpfung* max. Attenuation*				
	1000 MHz	2200 MHz	2700 MHz	3800 MHz	5825 MHz
SF 1/2"	0.112 dB/m	0.173 dB/m	0.195 dB/m	0.237 dB/m	0.304 dB/m

\* VSWR 1,0, Kabeltemperatur 20 °C, Werte ohne Steckverbinder; typische Dämpfung eines Steckverbinders ≤ 0,01 dB

\* VSWR 1.0, cable temperature 20 °C, values without connectors, typical connector attenuation is ≤ 0.01 dB

Kabeltyp Cable Type	max. Anschlussleistung* max. Power Rating*				
	1000 MHz	2200 MHz	2700 MHz	3800 MHz	5825 MHz
SF 1/2"	770 W	498 W	443 W	364 W	283 W

\* VSWR 1,0, Umgebungstemperatur 40 °C, Innenleitertemperatur 100 °C, keine Sonneneinstrahlung

\* VSWR 1.0, ambient temperature 40 °C, inner conductor temperature 100 °C, no solar loading

Kabeltyp Cable Type	min. Biegeradius, wiederholte Biegung min. Bending Radius, repeated Bending
SF 1/2"	32 mm

## CABLE ASSEMBLIES

### JUMPER SUPERFLEXIBLE 1/2"

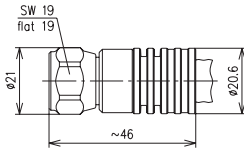

N Stecker  
N plug

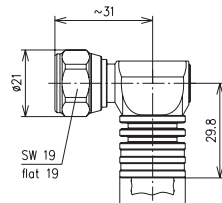

N Winkelstecker  
N right angle plug

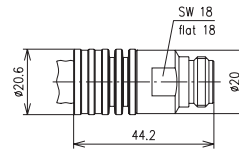

N Kuppler  
N socket

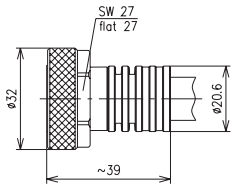

7-16 Stecker  
7-16 plug

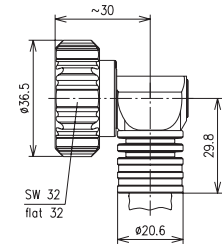

7-16 Winkelstecker  
7-16 right angle plug

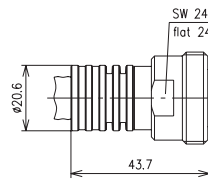

7-16 Kuppler  
7-16 socket

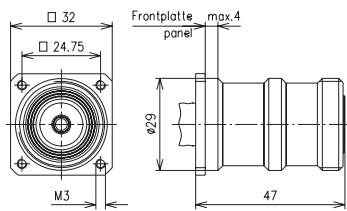

7-16 Gehäusekuppler mit Viereckflansch  
7-16 fixed socket with four hole mounting flange



JUMPER SUPERFLEXIBLE 1/2"

Länge L Length	Gewicht Weight	Bestell-Nummer Part Number
<b>7-16 Stecker/plug – 7-16 Stecker/plug</b>		
0.5 m	0.24 kg	BN J5 37 97
1.0 m	0.34 kg	BN J5 33 91
1.5 m	0.44 kg	BN J5 37 98
2.0 m	0.54 kg	BN J5 33 88
3.0 m	0.74 kg	BN J5 33 98
4.0 m	0.94 kg	BN J5 33 89
5.0 m	1.14 kg	BN J5 36 38
<b>7-16 Stecker/plug – 7-16 Kuppler/socket</b>		
0.5 m	0.25 kg	BN J5 36 89
1.0 m	0.35 kg	BN J5 39 60
1.5 m	0.45 kg	BN J5 39 61
2.0 m	0.55 kg	BN J5 37 94
3.0 m	0.75 kg	BN J5 37 51
4.0 m	0.95 kg	BN J5 37 41
5.0 m	1.15 kg	BN J5 38 31
<b>7-16 Stecker/plug – 7-16 Winkelstecker/right angle plug</b>		
0.5 m	0.30 kg	BN J5 40 25
1.0 m	0.40 kg	BN J5 38 24
1.5 m	0.50 kg	BN J5 38 25
2.0 m	0.60 kg	BN J5 37 95
3.0 m	0.80 kg	BN J5 37 96
4.0 m	1.00 kg	BN J5 38 26
5.0 m	1.20 kg	BN J5 40 13
<b>7-16 Stecker/plug – N Stecker/plug</b>		
0.5 m	0.22 kg	BN J5 40 58
1.0 m	0.32 kg	BN J5 38 34
1.5 m	0.42 kg	BN J5 38 35
2.0 m	0.52 kg	BN J5 38 38
3.0 m	0.72 kg	BN J5 38 36
4.0 m	0.92 kg	BN J5 40 72
5.0 m	1.12 kg	BN J5 40 66
<b>N Stecker/plug – N Stecker/plug</b>		
0.5 m	0.21 kg	BN J5 42 83
1.0 m	0.31 kg	BN J5 34 51
1.5 m	0.41 kg	BN J5 57 65
2.0 m	0.51 kg	BN J5 34 52
3.0 m	0.71 kg	BN J5 34 53
4.0 m	0.91 kg	BN J5 37 62
5.0 m	1.11 kg	BN J5 51 87
<b>N Stecker/plug – N Winkelstecker/right angle plug</b>		
0.5 m	0.23 kg	BN J5 67 78
1.0 m	0.33 kg	BN J5 40 81
1.5 m	0.43 kg	BN J5 47 85
2.0 m	0.53 kg	BN J5 43 23
3.0 m	0.73 kg	BN J5 42 96
4.0 m	0.93 kg	BN J5 00 56
5.0 m	1.13 kg	BN J5 58 56

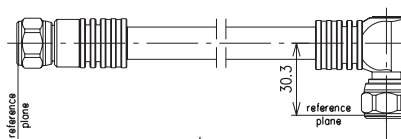
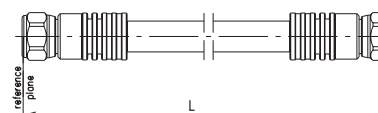
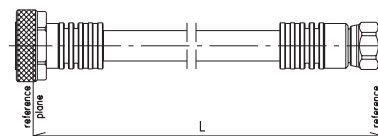
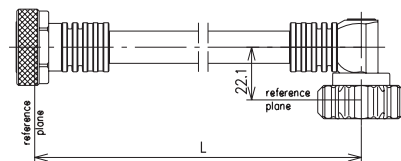
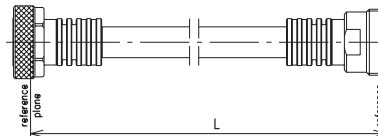
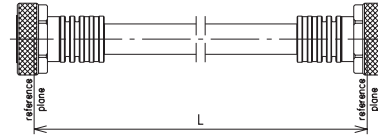

## CABLE ASSEMBLIES

### JUMPER SUPERFLEXIBLE 1/4", 3/8"

Wellenwiderstand Impedance	50 Ω				
Intermodulation (IM3) 2 x 20 W $f_1 = 1770 \text{ MHz}; f_2 = 1810 \text{ MHz}; f_{IM3} = 1850 \text{ MHz}$	≤ -160 dBc; typ. -165 dBc				
VSWR* für Stecksystem 7-16 und N VSWR* for connector size 7-16 and N	≤ 1000 MHz	≤ 2200 MHz	≤ 2700 MHz	≤ 3800 MHz	≤ 5825 MHz
Kabel mit 2 geraden Steckverbindern Cable with 2 straight connectors	≤ 1.05	≤ 1.07	≤ 1.08	≤ 1.10	≤ 1.12
Kabel mit 1 geraden und 1 Winkelstecker Cable with 1 straight and 1 right angle connector	≤ 1.06	≤ 1.08	≤ 1.09	≤ 1.11	≤ 1.13
Kabel mit 2 Winkelsteckverbindern Cable with 2 right angle connectors	≤ 1.07	≤ 1.09	≤ 1.10	≤ 1.12	≤ 1.14

\* typische VSWR Werte für Längen ≤ 5 m ; \* typical VSWR values for lengths ≤ 5 m

Kabeltyp Cable Type	max. Dämpfung* max. Attenuation*					min. Biegeradius, wiederholte Biegung min. Bending Radius, repeated Bending
	1000 MHz	2200 MHz	2700 MHz	3800 MHz	5825 MHz	
SF 3/8"	0.141 dB/m	0.217 dB/m	0.243 dB/m	0.295 dB/m	0.378 dB/m	25 mm
SF 1/4"	0.195 dB/m	0.301 dB/m	0.337 dB/m	0.410 dB/m	0.525 dB/m	25 mm

\* VSWR 1,0, Kabeltemperatur 20 °C, Werte ohne Steckverbinder, typische Dämpfung eines Steckverbinders ≤ 0,01 dB

\* VSWR 1,0, cable temperature 20 °C, values without connectors, typical connector attenuation is less than ≤ 0.01 dB

Kabeltyp Cable Type	max. Anschlussleistung* max. Power Rating*				
	1000 MHz	2200 MHz	2700 MHz	3800 MHz	5825 MHz
SF 3/8"	560 W	364 W	324 W	267 W	209 W
SF 1/4"	339 W	220 W	196 W	161 W	126 W

\* VSWR 1,0, Umgebungstemperatur 40 °C, Innenleitertemperatur 100 °C, keine Sonneneinstrahlung

\* VSWR 1,0, ambient temperature 40 °C, inner conductor temperature 100 °C, no solar loading

## CABLE ASSEMBLIES

### JUMPER SUPERFLEXIBLE 1/4"

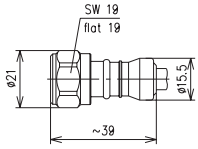

N Stecker  
N plug

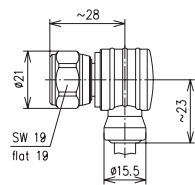

N Winkelstecker  
N right angle plug

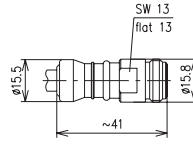

N Kuppler  
N socket

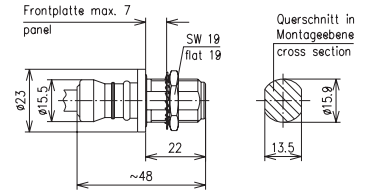

N Gehäusekuppler für Einlochmontage  
N fixed socket for single hole mounting

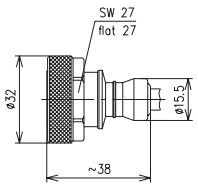

7-16 Stecker  
7-16 plug

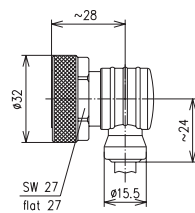

7-16 Winkelstecker  
7-16 right angle plug

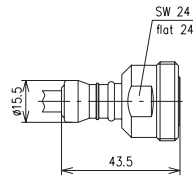

7-16 Kuppler  
7-16 socket

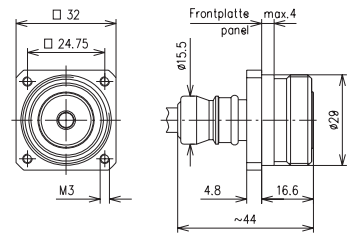

7-16 Gehäusekuppler mit Viereckflansch  
7-16 fixed socket with four hole mounting flange

### JUMPER SUPERFLEXIBLE 3/8"

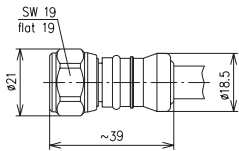

N Stecker  
N plug

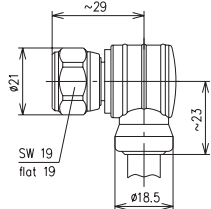

N Winkelstecker  
N right angle plug

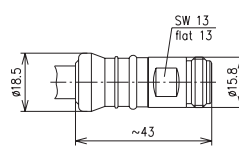

N Kuppler  
N socket

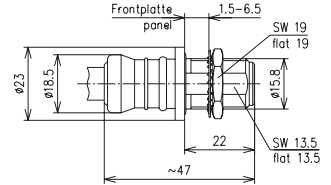

N Gehäusekuppler für Einlochmontage  
N fixed socket for single hole mounting

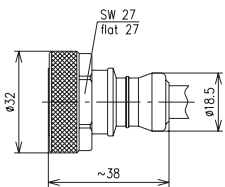

7-16 Stecker  
7-16 plug

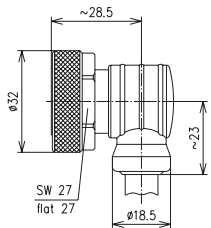

7-16 Winkelstecker  
7-16 right angle plug

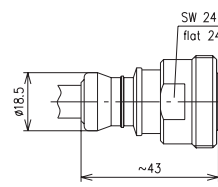

7-16 Kuppler  
7-16 socket

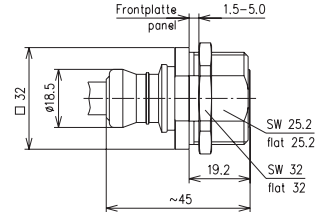

7-16 Gehäusekuppler für Einlochmontage  
7-16 fixed socket for single hole mounting

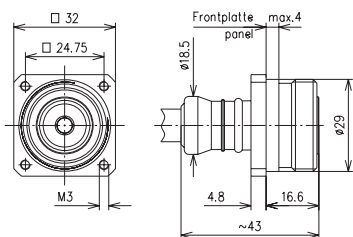

7-16 Gehäusekuppler mit Viereckflansch  
7-16 fixed socket with four hole mounting flange

CABLE ASSEMBLIES

JUMPER LOW LOSS FLEXIBLE 1/2"

Wellenwiderstand Impedance	50 Ω				
Intermodulation (IM3) 2 x 20 W $f_1 = 1770 \text{ MHz}; f_2 = 1810 \text{ MHz}; f_{IM3} = 1850 \text{ MHz}$	≤ -160 dBc; typ. -165 dBc				
VSWR* für Stecksystem 7-16 und N VSWR* for connector size 7-16 and N	≤ 1000 MHz	≤ 2200 MHz	≤ 2700 MHz	≤ 3800 MHz	≤ 5825 MHz
Kabel mit 2 geraden Steckverbindern Cable with 2 straight connectors	≤ 1.05	≤ 1.07	≤ 1.08	≤ 1.10	≤ 1.12
Kabel mit 1 geraden und 1 Winkelstecker Cable with 1 straight and 1 right angle connector	≤ 1.06	≤ 1.08	≤ 1.09	≤ 1.11	≤ 1.13
Kabel mit 2 Winkelsteckverbindern Cable with 2 right angle connectors	≤ 1.07	≤ 1.09	≤ 1.10	≤ 1.12	≤ 1.14

\* typische VSWR Werte für Längen ≤ 5 m ; \* typical VSWR values for lengths ≤ 5 m

Kabeltyp Cable Type	max. Dämpfung* max. Attenuation*					min. Biegeradius, wiederholte Biegung min. Bending Radius, repeated Bending
	1000 MHz	2200 MHz	2700 MHz	3800 MHz	5825 MHz	
LF 1/2"	0.072 dB/m	0.111 dB/m	0.124 dB/m	0.151 dB/m	0.193 dB/m	125 mm

\* VSWR 1,0, Kabeltemperatur 20 °C, Werte ohne Steckverbinder, typische Dämpfung eines Steckverbinders ≤ 0,01 dB

\* VSWR 1.0, cable temperature 20 °C, values without connectors, typical connector attenuation is ≤ 0.01 dB

Kabeltyp Cable Type	max. Anschlussleistung* max. Power Rating*				
	1000 MHz	2200 MHz	2700 MHz	3800 MHz	5825 MHz
LF 1/2"	1180 W	767 W	684 W	564 W	441 W

\* VSWR 1,0, Umgebungstemperatur 40 °C, Innenleitertemperatur 100 °C, keine Sonneneinstrahlung

\* VSWR 1.0, ambient temperature 40 °C, inner conductor temperature 100 °C, no solar loading

JUMPER LOW LOSS FLEXIBLE 1/2"

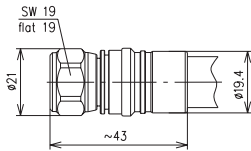

N Stecker  
N plug

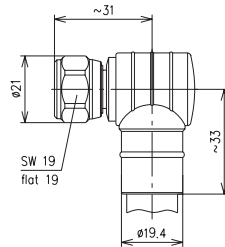

N Winkelstecker  
N right angle plug

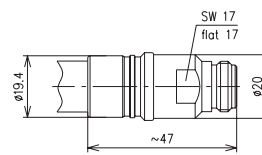

N Kuppler  
N socket

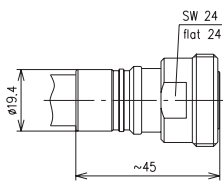

7-16 Kuppler  
7-16 socket

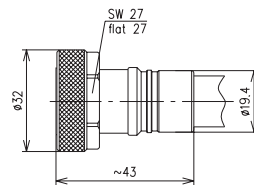

7-16 Stecker  
7-16 plug

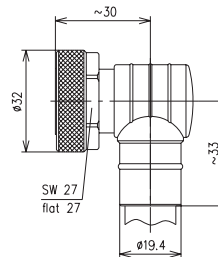

7-16 Winkelstecker  
7-16 right angle plug

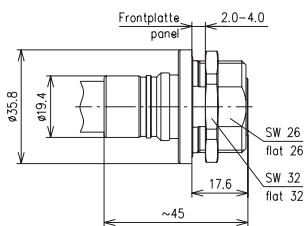

7-16 Gehäusekuppler  
für Einlochmontage  
7-16 fixed socket  
for single hole mounting

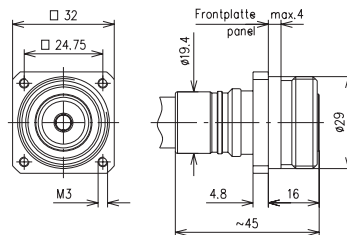

7-16 Gehäusekuppler  
mit Viereckflansch  
7-16 fixed socket with  
four hole mounting flange



## CABLE ASSEMBLIES

### SERIFLEX®

SERIFLEX® Kabel werden aus Rohkabeln mit komplett bleifrei verzinnem Kupfergeflecht als Außenleiter gefertigt. Diese Materialauswahl ermöglicht eine beliebig formstabile Biegung des Kabels, ohne dass die HF-Eigenschaften dadurch beeinflusst werden.

SPINNER liefert die Kabelgrößen 141-50 und 250-50 mit FEP Mantel. Kabelinnen- und Kabelaußenleiter sind mit dem Steckverbinder verlötet. SERIFLEX® Kabel können mit Steckverbindern der Typen SMA, N und 7-16 konfektioniert werden.

SERIFLEX® Kabel sind für Innenraummontage konzipiert und garantieren den Schutzgrad IP50 nach IEC 60529. Selbstverständlich erfüllen sie auch die RoHS 2002/95 Richtlinien.

SPINNER liefert beliebige Kabellängen und Steckverbinderkombinationen auf Anfrage.

SERIFLEX® cables are manufactured from raw cables with an outer conductor made of lead-free tin-plated copper mesh. This selection of materials allows you to permanently bend the cable as desired with the cable retaining its shape and its RF properties.

SPINNER delivers cable sizes 141-50 and 250-50 with FEP sheath. The inner and outer conductors of the cable are soldered onto the connector. SERIFLEX® cables can be customized using connector types SMA, N and 7-16.

SERIFLEX® cables are designed for indoor installation and guarantee protection rating IP50 under standard IEC 60529. They also meet the RoHS 2002/95 guideline.

Upon request SPINNER delivers any cable length and connector combination.

Kabeltyp Cable Type	max. Dämpfung* max. Attenuation*			Biegeradius, einmalig Bending Radius, single	Biegeradius, mehrmalig Bending Radius, repeated
	1000 MHz	2000 MHz	3000 MHz		
141-50-FEP	0.402 dB/m	0.601 dB/m	0.748 dB/m	≥ 1.5 x d	≥ 200 mm
250-50-FEP	0.238 dB/m	0.363 dB/m	0.517 dB/m	≥ 3.0 x d	≥ 400 mm

\* VSWR 1,0, Kabeltemperatur 20 °C, Werte ohne Steckverbinder, typische Dämpfung eines Steckverbinders ≤ 0,01 dB

\* VSWR 1,0, cable temperature 20 °C, values without connectors, typical connector attenuation is ≤ 0.01 dB

Kabeltyp Cable Type	max. Anschlussleistung* max. Power Rating*			max. Einsatzfrequenz max. Operating Frequency	Wellenwiderstand Impedance	50 Ω
	1000 MHz	2000 MHz	3000 MHz			
141-50-FEP	485 W	320 W	250 W	20 GHz	VSWR f ≤ 2200 MHz Länge/length ≤ 5 m	≤ 1.1 typ.
250-50-FEP	1220 W	820 W	640 W	18 GHz		

\* VSWR 1,0, Umgebungstemperatur 40 °C, Innenleitertemperatur 100 °C, keine Sonneneinstrahlung

\* VSWR 1,0, ambient temperature 40 °C, inner conductor temperature 100 °C, no solar loading

## CABLE ASSEMBLIES

### SERIFLEX® 141

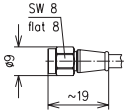

SMA Stecker  
SMA plug

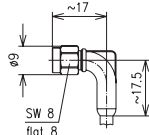

SMA Winkelstecker  
SMA right angle plug

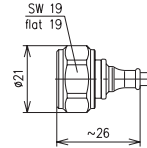

N Stecker  
N plug

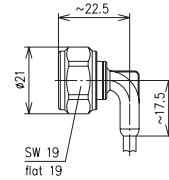

N Winkelstecker  
N right angle plug

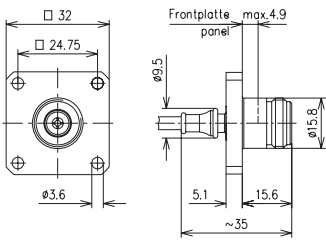

N Gehäusekuppel  
mit Viereckflansch  
N fixed socket with  
four hole mounting flange

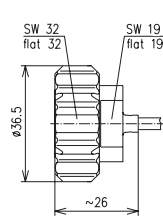

7-16 Stecker  
7-16 plug

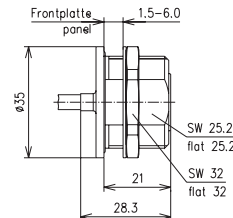

7-16 Gehäusekuppel  
für Einlochmontage  
7-16 fixed socket for  
single hole mounting

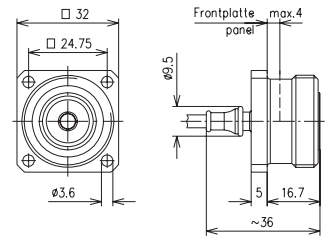

7-16 Gehäusekuppel  
mit Viereckflansch  
7-16 fixed socket with  
four hole mounting flange

### SERIFLEX® 250

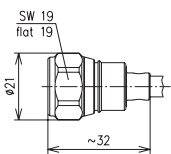

N Stecker  
N plug

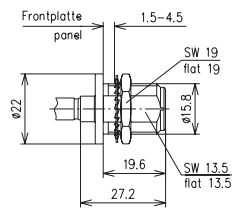

N Gehäusekuppel für Einlochmontage  
N fixed socket for single hole mounting

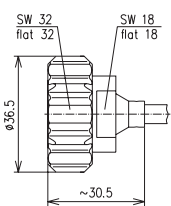

7-16 Stecker  
7-16 plug

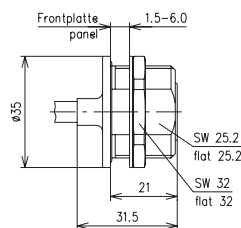

7-16 Gehäusekuppel für Einlochmontage  
7-16 fixed socket for single hole mounting

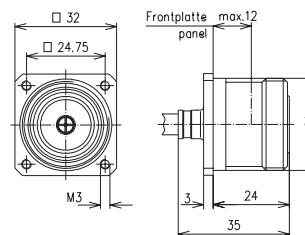

7-16 Gehäusekuppel mit Viereckflansch  
7-16 fixed socket with four hole mounting flange



## CABLE ASSEMBLIES

### GEFLECHTKABEL ■ BRAIDED CABLES

Diese Jumper Kabel werden aus dem Geflecht kabel RG223/U gefertigt und zeichnen sich durch eine hohe Flexibilität und kleine Biegeradien aus.

Der Kabelmantel ist halogenfrei und flammwidrig. Die Jumper können mit den Stecksystemen SMA, TNC und N konfektioniert werden.

Die Steckerinnenleiter sind mit dem Kabelinnenleiter verlötet, die Stecker außenleiter sind gecrimpt.

Geflecht kabel sind für Innenraummontage konzipiert und garantieren den Schutzgrad IP50 nach IEC 60529. Auf Anfrage bieten wir Sonderversionen, geprüft nach IEC 60529 mit Schutzgrad IP64 für Außenraummontage. Selbstverständlich erfüllen sie die RoHS 2002/95 Richtlinien.

SPINNER liefert beliebige Kabellängen und Steckverbinderkombinationen der aufgeführten Stecksysteme.

These jumper cables are manufactured from RG223/U mesh cables and stand out for their excellent flexibility and small bending radius.

The cable sheath is halogen-free and non-flammable. The jumpers can be customized with SMA, TNC and N type connectors. The inner conductor of the connector is soldered onto the cable's inner conductor, the outer conductor is crimped.

Mesh cables are designed for indoor installation and guarantee protection rating IP50 under standard IEC 60529. Upon request we offer special versions approved under IEC 60529 with protection rating IP64 for outdoor installation. They also meet the RoHS 2002/95 guideline.

SPINNER delivers any cable length and combination of the listed connector types.

Kabeltyp Cable Type	max. Dämpfung* max. Attenuation*		max. Anschlussleistung** max. Power Rating*		Biegeradius, einmalig Bending Radius, single	Biegeradius, mehrmalig Bending Radius, repeated
	1000 MHz	2000 MHz	1000 MHz	2000 MHz		
RG223-HFFR-50	0.400 dB/m	0.635 dB/m	55 W	35 W	≥ 30 mm	≥ 120 mm

\* VSWR 1,0, Kabeltemperatur 20 °C, Werte ohne Steckverbinder, typische Dämpfung eines Steckverbinders ≤ 0,01 dB

\* VSWR 1,0, cable temperature 20 °C, values without connectors, typical connector attenuation is ≤ 0.01 dB

\*\* VSWR 1,0, Umgebungstemperatur 40 °C, Innenleitertemperatur 100 °C, keine Sonneneinstrahlung

\*\* VSWR 1,0, ambient temperature 40 °C, inner conductor temperature 100 °C, no solar loading

Wellenwiderstand Impedance	50 Ω
VSWR f ≤ 2200 MHz Länge/length ≤ 5 m	≤ 1.1 typ.



### GEFLECHTKABEL ■ BRAIDED CABLES

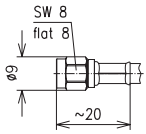

SMA Stecker  
SMA plug

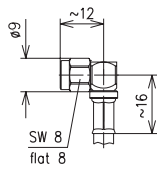

SMA Winkelstecker  
SMA right angle plug

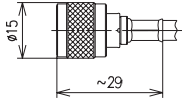

TNC Stecker  
TNC plug

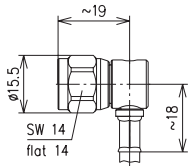

TNC Winkelstecker  
TNC right angle plug

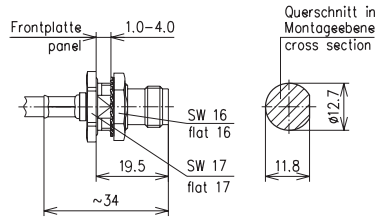

TNC Gehäusekuppler für Einlochmontage  
TNC fixed socket for single hole mounting

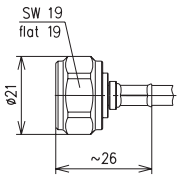

N Stecker  
N plug

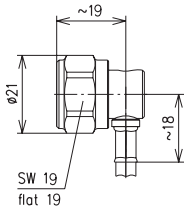

N Winkelstecker  
N right angle plug

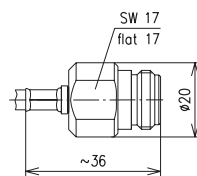

N Kuppler  
N socket

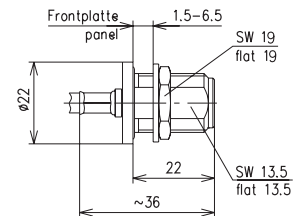

N Gehäusekuppler für Einlochmontage  
N fixed socket for single hole mounting



**25% ALLER SCHÄDEN IM ELEKTRONIKBEREICH  
WERDEN DURCH ÜBERSPANNUNGEN VERURSACHT.**

**25% OF ALL DAMAGES IN ELECTRONICS ARE  
CAUSED BY POWER SURGES.**

SPINNER hat sein Produktprogramm für koaxiale Überspannungsableiter erweitert und bietet ein hochwertiges Sortiment von verschiedenen Schutzelementen für koaxiale Systeme an. Dabei werden alle relevanten HF-Anwendungsbereiche abgedeckt für die ein Überspannungsschutz notwendig ist, wie z.B.:

- Schutz von Feststationen für analoge und digitale Kommunikation; 4 m-Sprechfunk, VHF-Bodenfunk in der Luftfahrt, 2 m-Zugfunk, TETRA, GSM900/1800, UMTS.
- Schutz von Kommunikationsleitungen in Tunneln mit Oberleitungen
- Schutz in Verbindung mit Strahlungskabeln
- Schutz von Einspeisung für Gleichstrom und Frequenzen bis 10 MHz (nach Antenna Interface Standards Group)

SPINNER has expanded the product range of coaxial surge protectors and offers premium choice of different protection elements for coaxial systems. It covers all relevant RF applications for which a surge protection is necessary e.g.:

- the protection of installations for analog and digital communication like such as 4 m radio, VHF ground radio in aviation, 2 m radio, TETRA, GSM900/1800, UMTS
- the protection of communication lines in tunnels with overhead contact wires
- the protection applications in connection with radiating cables
- the protection of Bias-Ts for DC and frequencies up to 10 MHz (according to Antenna Interface Standards Group)

Überspannungen werden hauptsächlich durch elektromagnetische Felder verursacht, die durch Blitzeinschläge in der nahen Umgebung erzeugt werden. Die Häufigkeit von Blitzen ist regional sehr unterschiedlich, eine grobe Abschätzung zeigt folgende Graphik:

Surges are mainly caused by electromagnetic fields generated by nearby lightning strikes. The frequency of lightning can vary by region. A rough estimation is given in the following chart:

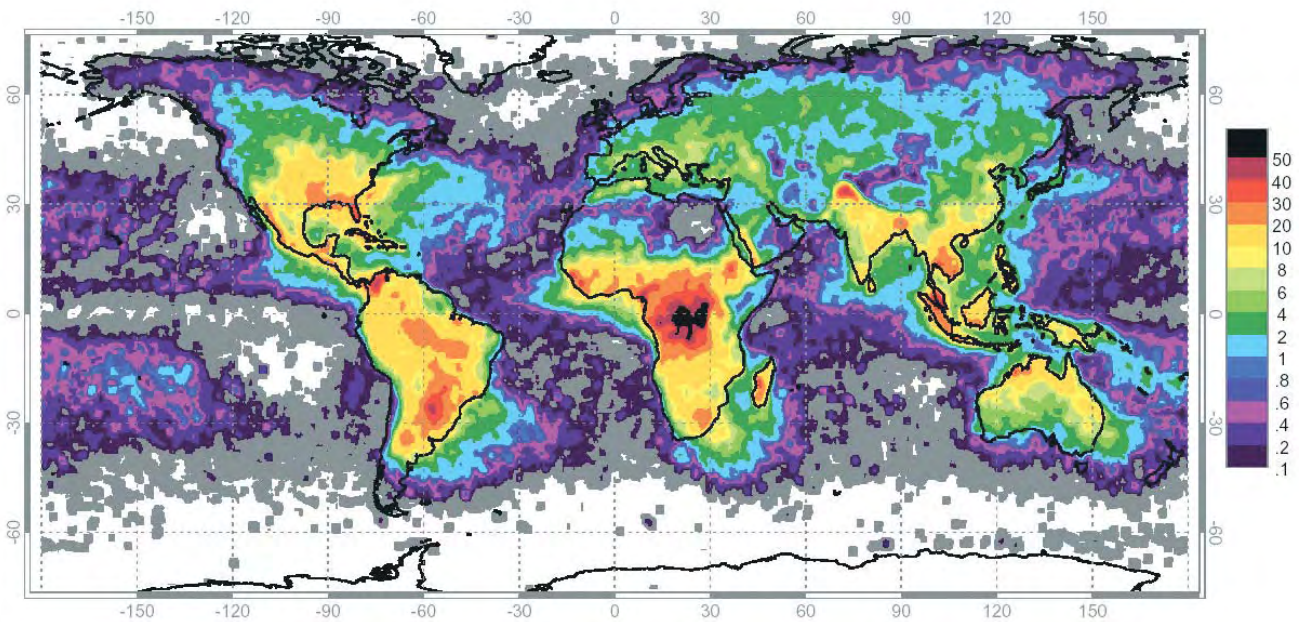

*Blitzhäufigkeit (Blitze/km<sup>2</sup>/Jahr) / Measured in flashes/km<sup>2</sup>/year*

Ein zuverlässiger Schutz vor Überspannungen ist nur bei korrekter Montage und regelmäßiger Wartung, je nach Überspannungsableitertyp, gewährleistet. Die Wartungsintervalle richten sich vor allem nach der Häufigkeit und Stärke der Impuls-Strombelastungen. Empfohlene Richtwerte für die Überspannungsableiter Typ I und Typ IV:

A reliable protection against surges is given only by a proper installation and regular maintenance depending on the protector type. The maintenance intervals depend mainly upon the number and the strength of the impulse current impacts. Recommended values for the surge protectors type I and type IV:

Stromstärke	Austausch nach Anzahl der Ereignisse
30 kA	1
10 (20*) kA	5
5 kA	10
1 kA	100

Current	Replacement after number of events
30 kA	1
10 (20*) kA	5
5 kA	10
1 kA	100

\*) gültig für 90 V und 230 V Ansprechspannung

\*) valid for 90 V and 230 V sparkover voltage

### Typ I – mit Gasentladungsableiter

#### Aufbau:

Ein Gasentladungsableiter besteht aus einem zylindrischen Isolator (meist Keramik) mit zwei leitenden Kappen an den Enden. Der Innenraum ist mit Edelgas unter definiertem Druck gefüllt.

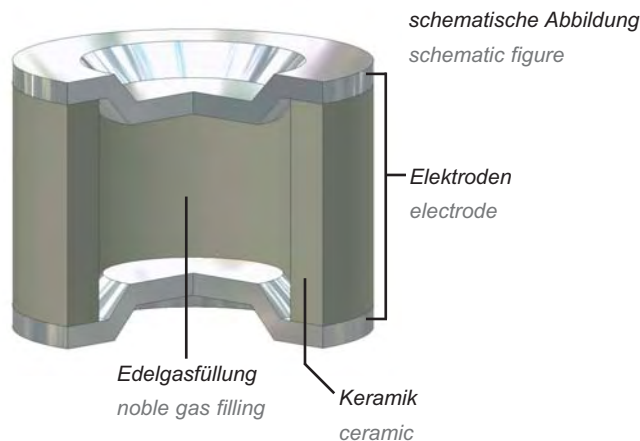

#### Funktion:

Der Ableiter hat bei Normalbetrieb einen quasi unendlichen Widerstand ( $> 1 \text{ G}\Omega$ ). Wenn die Spannung zwischen den Elektroden die Ansprechspannung übersteigt, kommt es zu einem Durchbruch und eine Entladung in Form eines Lichtbogens entsteht.

Die Ansprechspannung ist abhängig von der Anstiegsgeschwindigkeit der Spannung und vom Ableitertyp. Da die Entladung niederohmig ist, wird die Spannung zwischen den Elektroden auf die Brennspannung (typ. 20 V) reduziert. Der Ableitstrom kann dabei sehr hohe Werte annehmen ( $\geq 25 \text{ kA}$ ), bevor der Ableiter zerstört wird.

Wenn die Spannung zwischen den Elektroden die Brennspannung unterschreitet, erlischt der Lichtbogen und der Ableiter kehrt in den Normalzustand zurück.

### Type I – with Gas Discharge Arrestor:

#### Construction:

A gas discharge arrester consists of a cylindric insulator (mostly ceramics) with two conductive caps at the ends. The inside is filled with inert gas under defined pressure.

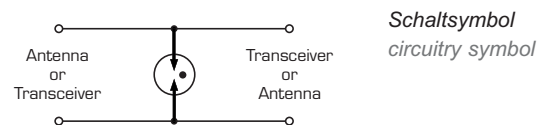

#### Function:

During normal operation the arrester has a quasi-infinite resistance ( $> 1 \text{ G}\Omega$ ). If the voltage between the electrodes rises above the sparkover voltage, a breakthrough and discharge in the form of an electrical arc occurs.

The sparkover voltage is dependent upon the rise time of the voltage and the type of arrester.

As the discharge is of low resistance the voltage between the electrodes is reduced to the arc (residual) voltage (typ. 20 V). The surge current can grow to very high values ( $\geq 25 \text{ kA}$ ) before the arrester is destroyed.

If the voltage between the electrodes falls below the arc voltage the arc extinguishes and the arrester returns to normal operation.

### Typ II – mit $\lambda/4$ Kurzschlussleitung

Aufbau:

Eine koaxiale Leitung mit definiertem Wellenwiderstand wird an einem Ende kurzgeschlossen und das andere Ende, in einer Entfernung ähnlich einer viertel Wellenlänge, der Hauptleitung parallelgeschaltet.

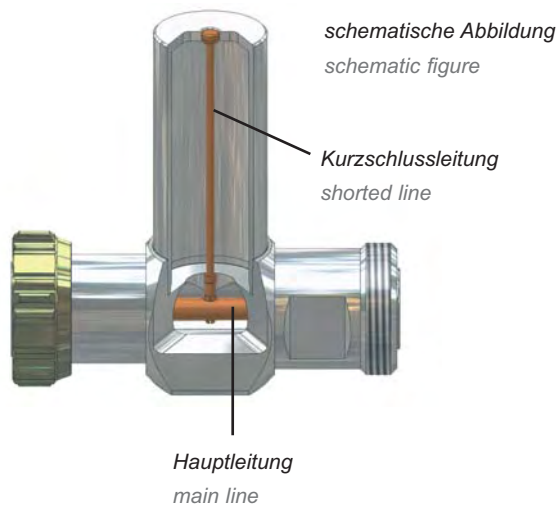

Funktion:

Der Kurzschluss der Leitung wird für die HF am anderen Ende in einen Leerlauf transformiert und beeinflusst dadurch die Hauptleitung unwesentlich.

Es entsteht ein einfaches Bandpass Filter mit der  $\lambda/4$ -Frequenz als Mittelfrequenz. Die Kenndaten der Leitung (Wellenwiderstand  $Z_L$  und Länge  $l$ ) zusammen mit zusätzlichen Transformationselementen in der Hauptleitung sind für die Betriebsbandbreite verantwortlich. Durch die galvanische Verbindung von Innen- und Außenleiter ist eine Gleichstromübertragung nicht möglich. Das Fehlen eines nichtlinearen Bauteils (wie z.B. Gasentladungsableiter) ermöglicht eine hohe Intermodulationsfestigkeit.

Die Kurzschlussleitung kann rechtwinklig abstehen oder in Richtung der Achse der Hauptleitung gefaltet sein (Inline-Design).

### Type II – with Quarter Wavelength Stub

Construction:

A coaxial line with a defined characteristic impedance is short-circuited at one end. The other end of the line with a length similar to a quarter wavelength is connected parallel to the main line.

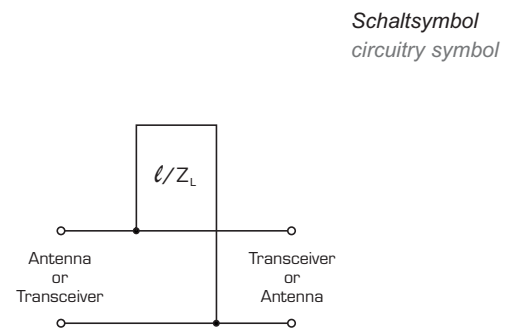

Schaltsymbol  
circuitry symbol

Function:

The short at the end of the stub is transformed to an open at the bottom. Thus the RF on the main line is essentially influenced, and the stub acts like a simple bandpass filter with the quarter-wave frequency as centre frequency.

The nature of the stub line (characteristic impedance  $Z_L$  and length  $l$ ) together with additional transforming elements in the main line is responsible for the operating bandwidth of the device.

Because of the galvanic connection of inner and outer conductor, a DC transmission is not possible.

The missing of any non-linear component (like e.g. a gas discharge arrester) secures very low intermodulation.

The stub can be radial to or folded into the axis of the main line (In line design).

### Weitere Varianten und Kombinationen

#### Typ III – mit $\lambda/4$ -Kurzschlussleitung und DC-Block

Eine Variante der  $\lambda/4$ -Technik ist ein DC-Block in der Hauptleitung. Er dient sowohl der Erhöhung der Bandbreite, als auch der Reduzierung von Restspannung und Restenergie. Diese Variante kann nicht bidirektional betrieben werden.

#### Typ IV – mit $\lambda/4$ -Kurzschlussleitung und Gasentladungsableiter (Hybrid-Technik)

Die Hybrid-Technik kombiniert beide Schutztechniken. Der Kurzschluss am Ende der Leitung wird ersetzt durch eine Kapazität und einen Gasentladungsableiter. Der Innen- und Außenleiter der Hauptleitung sind nicht mehr galvanisch verbunden, so dass Gleichstrom und Niederfrequenz übertragen werden können.

Die Hauptleitung ist durch die  $\lambda/4$ -Leitung von den Effekten des Ableiters entkoppelt und umgekehrt, dadurch ist der Ableiter im Normalbetrieb frei von Last.

#### Typ V / VI – DC-Einspeisung ohne/mit Modem

Varianten der Hybrid-Technik sind die DC-Einspeisungen, bei denen am Kurzschlussende ein Tiefpass und ein DC-Anschluss bzw. ein Modem ergänzt wird. Der Innenleiter der Einspeisung ist senderseitig DC-geblockt.

Als Option kann ein Modem integriert werden, mit dessen Hilfe digitale Steuersignale für die Systemkomponenten der Gleichspannung gemäß der AISG 2.0-Spezifikation überlagert werden.

Bei der Gleichspannung kann dabei zwischen 12 V und 24 V gewählt werden. Der Eingangsstrom in die Einspeisung ist mit 5 A gesichert. Das Modem wird HF-seitig durch einen zusätzlichen Varistor als Feinschutz vor Über- bzw. Störspannungen geschützt.

### Further Modifications and Combinations

#### Type III – with Quarter Wavelength Stub and DC Break

A modification of the quarter wave type is a DC break in the main line. The DC break extends the bandwidth and decreases the residual voltage and energy. This type cannot be used bidirectionally.

#### Type IV – with Quarter Wavelength Line and Gas Discharge Arrestor (Hybrid)

The Hybrid type combines both protection mechanisms. The short at the end of the  $\lambda/4$  line is replaced by a capacity and a gas discharge arrestor.

The inner and outer conductor of the main line are not connected galvanically, therefore DC and low frequency can be transmitted.

The main line is decoupled from the effects of the arrestor and vice versa by the quarter wavelength line. Thus the arrestor is free of electrical stress in normal operation.

#### Types V and VI – Bias-T without/with modem

Modifications of the Hybrid types are the Bias-Ts. For both a low-pass and a DC connection respectively, a modem is added to the end of the quarter wavelength line. The inner conductor of the main line is DC-blocked to the transmitter.

As an option a modem can be integrated to overlay the DC voltage with digital control signals for system components according to the AISG 2.0 specification.

The DC voltage here can be chosen between 12 V and 24 V. The input current into the feed is fused with 5 A. The modem is protected at the RF end from surges and interfering voltages by an additional varistor as fine protection.

Type	Anwendung Application	Vorteile Advantages	Bemerkung Remark
<b>Typ I</b> Gasentladungsableiter	- universell breitbandig - von DC bis 2500 MHz	- DC-Übertragung möglich	- Wartung notwendig - HF-Leistung begrenzt - hohe Intermodulation
<b>Typ I</b> Gas Discharge Arrestor	- universal broadband - from DC to 2500 MHz	- DC transmission possible	- maintenance necessary - RF power limited - high intermodulation
<b>Typ II</b> $\lambda/4$ Kurzschlussleitung	- bis zu 3 Mobilfunkbänder - von 380 bis 2200 MHz	- keine Wartung - hohe HF-Leistung - sehr geringe Intermodulation	- keine DC-Übertragung
<b>Typ II</b> Quarter Wavelength Stub	- up to 3 mobile bands - from 380 to 2200 MHz	- no maintenance - high RF power - very low intermodulation	- no DC transmission possible
<b>Typ III</b> $\lambda/4$ Kurzschlussleitung mit DC-Block	- alle Mobilfunkbänder - von 800 bis 2500 MHz	- wie Typ II - Restspannung u. -energie nahezu 0	- keine DC-Übertragung
<b>Typ III</b> Quarter Wavelength Stub with DC break	- all mobile bands - from 800 to 2500 MHz	- like type II - nearly 0 residual voltage and energy	- no DC transmission possible
<b>Typ IV</b> Hybrid	- alle Mobilfunkbänder mit aktiven Elementen an der Antenne	- DC-Übertragung möglich - hohe HF-Leistung - geringe Intermodulation	- Wartung notwendig
<b>Typ IV</b> Hybrid	- all mobile bands with active elements at the antenna	- DC transmission possible - high RF power - low intermodulation	- maintenance necessary
<b>Typ V</b> DC-Einspeisung	- 3 Mobilfunkbänder mit DC-Einspeisung für aktive Elemente an der Antenne	- hohe DC-Spannung/Strom - hohe HF-DC-Entkopplung - geringe Intermodulation - eingebauter Überspannungsableiter - DC geblockt in Richtung BTS	- Ableiter nicht austauschbar
<b>Typ V</b> Bias -T	- 3 mobile bands with DC feed for active elements at the antenna	- high DC voltage and current - high RF/DC isolation - low intermodulation - integrated surge protector - DC blocked in direction to BTS	- Arrestor not replaceable
<b>Typ VI</b> DC-Einspeisung mit Modem	- 3 Mobilfunkbänder mit DC- und Dateneinspeisung für Mastverstärker und RET- Antennen	- wie Typ V - Datenübertragung gemäß AISG 2.0 - zusätzlicher Feinschutz	- Ableiter und Feinschutz nicht austauschbar
<b>Typ VI</b> Bias-T with Modem	- 3 mobile bands with DC and data feed for mast amplifiers and RET antennas	- like type V - data transmission accord. to AISG 2.0 - additional fine protector	- Arrestor and fine protection not replaceable





Überspannungsableiter mit Gasentladungsableiter können für alle Anwendungen im Frequenzbereich von 0 bis 2,5 GHz eingesetzt werden. Dabei ist die HF-Anschlussleistung durch die Ansprechspannung des Ableitertyps begrenzt.

Surge Protectors with gas discharge arrestor can be used for all applications in the frequency range of 0 to 2.5 GHz. The RF power rating is limited by the sparkover voltage of the discharge arrestor.

- Symmetrischer Aufbau (beidseitig geschützt)
- geeignet für Außenmontage
- DC-Übertragung über Innenleiter möglich
- Gasentladungsableiter einfach austauschbar
- Austausch alle 3 bis 4 Jahre empfohlen
- Ableiter frei von Radioaktivität
- Symmetrical design (both sides protected)
- Suitable for outdoor installation
- DC transmission via inner conductor possible
- Gas discharge arrestor easily replaceable
- Replacement recommended every 3 to 4 years
- Arrestors free of radioactivity

#### Gehäuse für Gasentladungsableiter ■ Housings for Gas Discharge Arrestors

Anschluss 1 Connection 1	Anschluss 2 Connection 2	Bestell-Nummer * Part Number
7-16 Stecker/Plug	7-16 Gehäusekuppler/Fixed Socket 1-Lochmontage/bulkhead mounting M29	BN 19 42 84
7-16 Gehäusestecker/Fixed Plug 4-Lochmontage/4 hole mounting	7-16 Kuppler/Socket	BN 19 42 82
7-16 Gehäusekuppler/Fixed Socket 1-Lochmontage/bulkhead mounting M29	7-16 Kuppler/Socket	BN 92 04 80
N Stecker/Plug	N Gehäusekuppler/Fixed Socket 1-Lochmontage/bulkhead mounting 5/8"	BN 95 08 80
N Kuppler/Socket	N Gehäusekuppler/Fixed Socket 1-Lochmontage/bulkhead mounting 5/8"	BN 95 08 88

\*) andere Kombinationen und Steckverbindertypen auf Anfrage / other combinations and connector types on request

**Gasentladungsableiter ■ Gas Discharge Arrestors**

Bestellnummer Part Number	BN A7 13 07	BN A7 13 08	BN A7 13 11	BN A7 13 13
stat. Ansprechspannung (100 V/s)* Stat. sparkover voltage	90 ± 20 V	230 ± 35 V	600 +120 / -90 V	1000 ± 200 V
dyn. Ansprechspannung (1 kV/µs) Dyn. sparkover voltage	≤ 700 V	≤ 750 V	≤ 1200 V	≤ 1600 V
Bogenbrenn- (Rest-)spannung Arc (residual) voltage	≤ 25 V			≤ 30 V
zulässiger Ableitstoßstrom Permitted surge current	einmalig/single (8/20 µs)	25 kA		
	mehrmalig/multiple (8/20 µs) 5 Impulse/pulses in 3 min.	20 kA	10 kA	10 kA
HF Anschlussleistung, unmoduliert; VSWR = 1; N.N.; 40 °C RF power rating, unmodulated; VSWR = 1; sea level; 40 °C	≤ 20 W	≤ 180 W	≤ 1200 W	≤ 3000 W
Abmessungen Dimensions	ø 8 / H 6 mm			ø 8 / H 6.8 mm

\*) andere Spannungen auf Anfrage / other voltages on request

**Typische Daten mit Gasentladungsableiter ■ Typical Data with Gas Discharge Arrestor**

Frequenzbereich Frequency range		DC ... 2.5 GHz
Wellenwiderstand Impedance		50 Ω
VSWR	DC ... 1.0 GHz >1.0 ... 2.5 GHz	≤ 1.06 ≤ 1.20
Dämpfung Insertion loss		≤ 0.1 dB
Anschlussmaßnorm Mating face standard	7-16 N	gem./accord. to IEC 60169-4 gem./accord. to IEC 60169-16
Kupplungsdrehmomente Coupling torques	7-16 N	25 ... 30 Nm 3 Nm
Innenleiter Inner conductor		Messing versilbert brass silver plated
Außenleiter Outer conductor		Messing versilbert brass silver plated
sonstige Metallteile Other metal parts		Messing vernickelt brass nickel plated
Isolation Insulation		PTFE
Dichtung Sealing		Silikon silicone
Betriebstemperatur Operating temperature range		-40 °C ... +85 °C
Schutzgrad (gesteckter Zustand) Degree of protection (mated condition)		IP67



BN 19 42 84

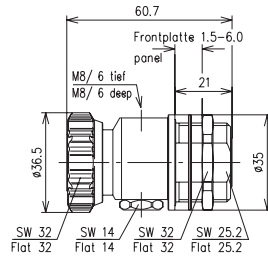

Querschnitt in Montageebene  
Cross section in mounting plane

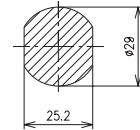

BN 19 42 82

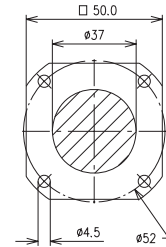
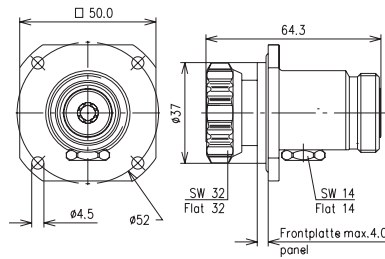

BN 92 04 80

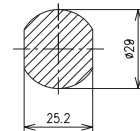
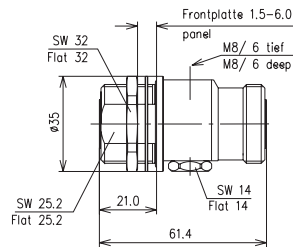

BN 95 08 80

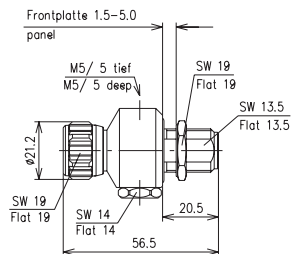

BN 95 08 88

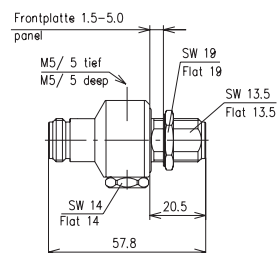



Diese Art von Überspannungsableiter ist zur Anwendung im Mobilfunk für einzelne sowie bis zu drei zusammengefasste Bänder (z.B. GSM900, GSM1800 und UMTS) geeignet. Dabei ist keine Übertragung von Gleichstrom über die Koaxanschlüsse möglich. Die Kurzschlussleitung kann rechtwinklig abstehen oder in Achse der Hauptleitung gefaltet (Inline-Bauart) sein.

This kind of surge protector is suitable for applications with single or up to three combined mobile communication bands (e.g. GSM900, GSM1800 and UMTS). DC transmission via the coaxial ports is not possible with this type. The stub can be radial to, or folded into the axis of the main line (In line design).

- symmetrischer Aufbau, beidseitig geschützt
  - hohe HF-Anschlussleistung
  - sehr niedrige Intermodulation
  - geeignet für Außenmontage
  - wartungsfrei
- Symmetrical design (both sides protected)
  - High RF power rating
  - Very low intermodulation
  - Suitable for outdoor installation
  - Maintenance free

Anschluss 1* Connection 1	Anschluss 2* Connection 2	Bestell-Nummer / Part Number	
		380 ... 512 MHz	800 ... 2170 MHz
7-16 Stecker/Plug	7-16 Kuppler/Socket	BN 76 64 19	BN 75 64 73**
7-16 Kuppler/Socket	7-16 Kuppler/Socket	–	BN 75 64 74**

\*) andere Kombinationen auf Anfrage / other combinations on request

\*\*\*) mit montiertem Erdungskabel (siehe Seite 63) / with mounted grounding cable (see page 63)

## TYP II - MIT $\lambda/4$ KURZSCHLUSSLEITUNG



## TYP II - WITH QUARTER WAVELENGTH STUB

### Typische Daten ■ Typical Data

Frequenzbereich Frequency range	380 .. 520 MHz	800 .. 2170 MHz
Wellenwiderstand Impedance	50 $\Omega$	
VSWR	$\leq 1.20$ (380 ... 430 MHz) $\leq 1.22$ (> 430 ... 520 MHz)	$\leq 1.11$
Dämpfung Insertion loss	$\leq 0.1$ dB	
zulässige HF-Leistung RF power rating	$\leq 3$ kW	$\leq 0.95$ kW (800 MHz) $\leq 0.60$ kW (2170 MHz)
zulässiger Ableitstoßstrom Allowed surge current (8/20 $\mu$ s)	50 kA	60 kA
Prüfimpuls Test pulse	4 kV (1.2/50 $\mu$ s) / 2 kA (8/20 $\mu$ s)	
Restspannung bei Prüfimpuls Residual voltage at test pulse	$\leq 20$ V	$\leq 5.8$ V
Restenergie bei Prüfimpuls Residual energy at test pulse	$\leq 20$ $\mu$ J	$\leq 7$ $\mu$ J
Intermodulation (IM3) 2 x 20 W 936/958 MHz; 1770/1810 MHz	–	$\leq -160$ dBc
Anschlussmaßnorm Mating face standard	gem./accord. to IEC 60169-4	
Kupplungsdrehmoment Coupling torque	25 ... 30 Nm	
Innenleiter Inner conductor	Messing versilbert brass silver plated	
Außenleiter Outer conductor	Messing versilbert brass silver plated	
sonstige Metallteile other metal parts	Messing vernickelt brass nickel plated	
Isolation Insulation	PTFE	
Dichtung Sealing	Silikon silicone	
Betriebstemperatur Operating temperature range	-40 °C ... +85 °C	
Schutzgrad (gesteckter Zustand) Degree of protection (mated condition)	IP67	



BN 76 64 19

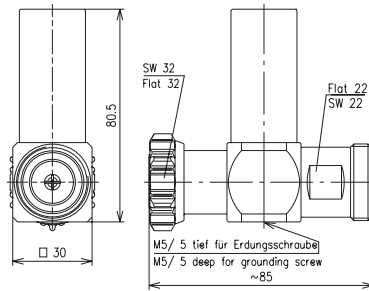

BN 75 64 73

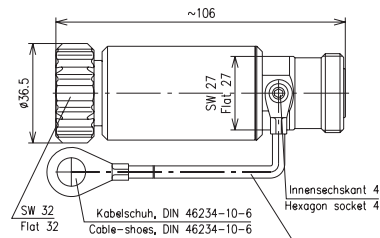

Potentialausgleich, Länge: 600mm Querschnitt: 6mm<sup>2</sup>  
 cable for potential equalisation, lengt: 600mm cross section: 6mm<sup>2</sup>



BN 75 64 74

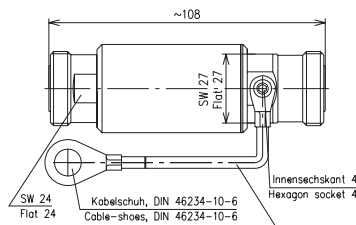

Potentialausgleich, Länge: 600mm Querschnitt: 6mm<sup>2</sup>  
 cable for potential equalisation, lengt: 600mm cross section: 6mm<sup>2</sup>

Zubehör ■ Accessory



BN A7 13 67

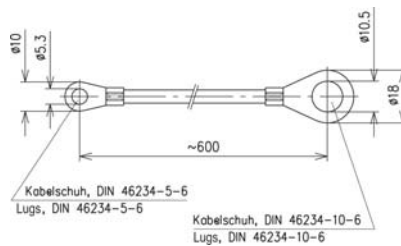

Erdungskabel  
 Länge 600 mm  
 Kabelseil Li2Y 1x6 mm<sup>2</sup>  
 PE-isoliert schwarz  
 mit gecrimpten Kabelschuhen für M5/M10

Grounding cable  
 Length 600 mm  
 Ground lead Li2Y 1x6 mm<sup>2</sup>  
 Black PE insulation  
 With crimped ground lugs for M5/M10 screws







## TYP III - MIT $\lambda/4$ KURZSCHLUSSLEITUNG UND DC-BLOCK

### TYP III - WITH QUARTER WAVELENGTH STUB AND DC BREAK

Der aufgetrennte Innenleiter dieser Typen bietet gleichzeitig eine erhöhte Schutzwirkung und eine größere Bandbreite (800 bis 2500 MHz). Damit kann der gesamte Frequenzbereich der gebräuchlichsten Mobilfunkbänder sowie die drahtlosen Datenübertragungen mit W-LAN nach IEEE 802.11b/g oder Bluetooth mit einem einzigen Überspannungsableiter abgedeckt werden. Durch die Auftrennung ergibt sich, dass diese Ausführung nicht symmetrisch ist, d.h. definierte Anschlüsse für Antenne und geschützte Sender-Empfängerseite aufweist.

The internally separated inner conductor improves the protection effect and extends the bandwidth (800 to 2500 MHz).

Therefore the whole frequency range of the most common mobile communication bands and W-LAN data transmission accord. to IEEE 802.11b/g or Bluetooth can be covered by one protector only. On the other hand the DC break type is not symmetric, i.e. there are defined ports for the antenna and for the protected transceiver side.

- unsymmetrischer Aufbau (nur eine Seite geschützt)
- sehr hohe Schutzwirkung durch Reduzierung der Restspannung und -energie auf nahezu Null
- hohe HF-Anschlussleistung
- sehr geringe Intermodulation
- geeignet für Außenmontage
- wartungsfrei
- Asymmetric design (only one side protected)
- Very high protection almost 0 residual voltage and energy
- High RF power rating
- Very low intermodulation
- Suitable for outdoor installation
- Maintenance free

Antennen-Anschluss 1 Antenna Connection 1	geschützter Anschluss 2 Protected Connection 2	Bestell-Nummer Part Number
7-16 Stecker/Plug	7-16 Gehäusekuppler/Fixed Socket 1-Lochmontage/bulkhead mounting M29	BN 76 64 13
7-16 Gehäusekuppler/Fixed Socket 1-Lochmontage/bulkhead mounting M29	7-16 Stecker/Plug	BN 76 64 03
7-16 Gehäusekuppler/Fixed Socket 1-Lochmontage/bulkhead mounting M29	7-16 Gehäusekuppler/Fixed Socket* 1-Lochmontage/bulkhead mounting M29	BN 75 64 78
7-16 Gehäusestecker/Fixed Plug 1-Lochmontage/bulkhead mounting M40	7-16 Kuppler/Socket	BN 76 64 07
7-16 Kuppler/Socket	7-16 Gehäusestecker/Fixed Plug 1-Lochmontage/bulkhead mounting M40	BN 76 64 18

\*) 1 x O-Ring, 6kt-Mutter, Scheibe / 1 x O-Ring, hex nut, washer

## TYP III - MIT $\lambda/4$ KURZSCHLUSSLEITUNG UND DC-BLOCK



## TYP III - WITH QUARTER WAVELENGTH STUB AND DC BREAK

### Typische Daten ■ Typical Data

Frequenzbereich Frequency range		800 ... 2500 MHz
Wellenwiderstand Impedance		50 $\Omega$
VSWR	800 ... 2500 MHz 850 ... 2450 MHz	$\leq 1.14$ $\leq 1.11$
Dämpfung Insertion loss		$\leq 0.1$ dB
zulässige HF-Leistung RF power rating		$\leq 3.0$ kW (800 MHz) $\leq 1.7$ kW (2500 MHz)
zulässiger Ableitstoßstrom Allowed surge current	8/20 $\mu$ s 10/350 $\mu$ s	100 kA 50 kA
Prüfimpuls Test pulse		4 kV (1.2/50 $\mu$ s) / 2 kA (8/20 $\mu$ s)
Restspannung bei Prüfimpuls Residual voltage at test pulse		< 15 mV
Restenergie bei Prüfimpuls Residual energy at test pulse		< 15 nJ
Intermodulation (IM3) 2 x 20 W		$\leq -165$ dBc
Anschlussmaßnorm Mating face standard		gem./accord. to IEC 60169-4
Kupplungsdrehmoment Coupling torque		25 ... 30 Nm
Innenleiter Inner conductor		Messing oder CuBe versilbert brass or CuBe silver plated
Außenleiter Outer conductor		Messing versilbert brass silver plated
sonstige Metallteile other metal parts		Messing vernickelt brass nickel plated
Isolation Insulation		PTFE
Dichtung Sealing		Silikon silicone
Betriebstemperatur Operating temperature range		-40 °C ... +85 °C
Schutzgrad (gesteckter Zustand) Degree of protection (mated condition)		IP67



# TYP III - MIT $\lambda/4$ KURZSCHLUSSLEITUNG UND DC-BLOCK

## TYP III - WITH QUARTER WAVELENGTH STUB AND DC BREAK



BN 76 64 13

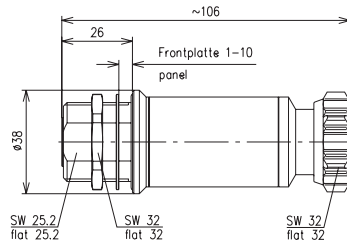

Querschnitt in Montageebene  
Cross section in mounting plane

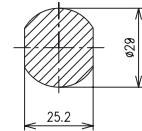

BN 76 64 03

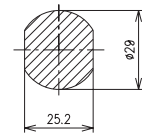
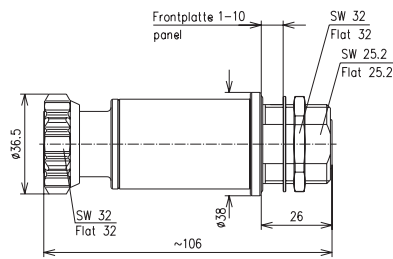

BN 75 64 78

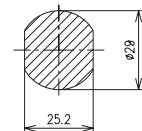
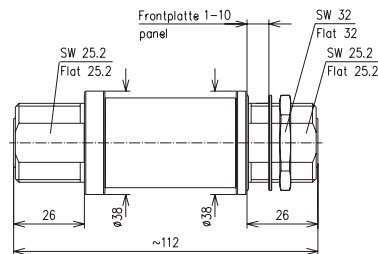

BN 76 64 07

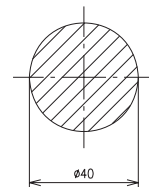
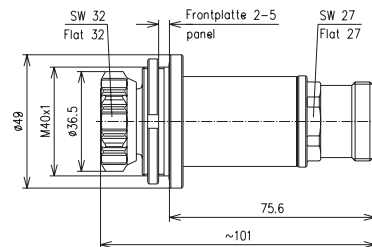

BN 76 64 18

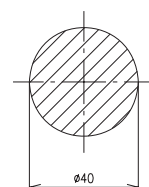
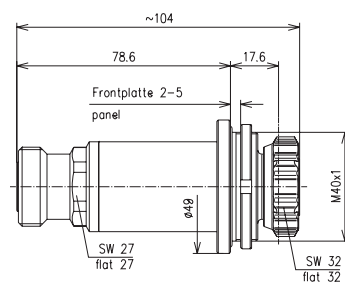





## TYP IV - MIT $\lambda/4$ LEITUNG UND GASENTLADUNGSABLEITER

### TYP IV - WITH QUARTER WAVELENGTH LINE AND GAS DISCHARGE ARRESTOR

Diese Ausführung vereint die Vorteile der beiden Schutztechniken (Gleichstromübertragung und Intermodulationsfestigkeit).

Sie wird deshalb auch Hybrid-Technik genannt.

Die Bandbreite beträgt 800 MHz bis 2500 MHz sowie 0 bis 10 MHz. Da neben Gleichstrom auch Niederfrequenz störungsfrei übertragen wird, können diese Überspannungsableiter auch mit Steuersignalen (nach AISG) von Antennenverstärkern und/oder ferngesteuerten Antennen verwendet werden.

- symmetrischer Aufbau (beidseitig geschützt)
- breitbandig niedriges VSWR
- hohe HF-Anschlussleistung
- hohe Gleichspannungs- und -strombelastung
- sehr niedrige Intermodulation
- Ableiter frei von Radioaktivität
- Ableiter einfach austauschbar
- Austausch alle 8 bis 10 Jahre empfohlen
- geeignet für Außenmontage

This surge protector design combines the advantages of both protecting techniques (DC transmission and low intermodulation).

Therefore it is also called a hybrid design.

The bandwidth is 800 MHz to 2500 MHz and 0 to 10 MHz. Suitable for DC and low frequency (LF) transmission these surge protectors can also be used to control signals (according to AISG) of antenna amplifiers and/or remote controlled antennas.

- Symmetrical design (both sides protected)
- Broadband low VSWR
- High RF power rating
- High DC voltage and current rating
- Very low intermodulation
- Arrestor free of radioactivity
- Arrestor easy to replace
- Recommended replacement every 8 to 10 years
- Suitable for outdoor installation

Anschluss 1 Connection 1	Anschluss 2 Connection 2	Bestell-Nummer Part Number
7-16 Gehäusekuppler/Fixed Socket 1-Lochmontage/Bulkhead mounting M29	7-16 Gehäusekuppler/Fixed Socket* 1-Lochmontage/Bulkhead mounting M29	BN 76 64 21
7-16 Stecker/Plug	7-16 Gehäusekuppler/Fixed Socket 1-Lochmontage/Bulkhead mounting M29	BN 75 64 95
7-16 Gehäusekuppler/Fixed Socket 1-Lochmontage/Bulkhead mounting 1 1/4"	7-16 Kuppler/Socket	BN 76 64 22
7-16 Gehäusestecker/Fixed Plug 1-Lochmontage/Bulkhead mounting M40	7-16 Kuppler/Socket	BN 76 64 23
	Ersatzableiter	BN A7 22 45

\*) 1 x O-Ring, 6kt-M., Scheibe / 1 x O-Ring, hex nut, washer

## TYP IV - MIT $\lambda/4$ LEITUNG UND GASENTLADUNGSABLEITER



### TYP IV - WITH QUARTER WAVELENGTH LINE AND GAS DISCHARGE ARRESTOR

#### Typische Daten ■ Typical Data

Frequenzbereich Frequency range		800 ... 2500 MHz (0 ... 10 MHz)
Wellenwiderstand Impedance		50 $\Omega$
VSWR	800 ... 2500 MHz 850 ... 2450 MHz	$\leq 1.14$ $\leq 1.11$
Dämpfung Insertion loss		$\leq 0.1$ dB
zulässige HF-Leistung RF power rating		$\leq 3.0$ kW (800 MHz) $\leq 1.7$ kW (2500 MHz)
zulässiger Ableitstoßstrom Allowed surge current	einmalig/single mehrmalig/multiple	25 kA (8/20 $\mu$ s) 20 kA (8/20 $\mu$ s)
Prüfimpuls Test pulse		4 kV (1.2/50 $\mu$ s) / 2 kA (8/20 $\mu$ s)
Restenergie bei Prüfimpuls Residual energy at test pulse		$\leq 350$ $\mu$ J
stat. Ansprechspannung des Gasentladungsableiters stat. sparkover voltage of the gas discharge arrestor		90 V $\pm$ 20 V
Intermodulation (IM3) 2 x 20 W		$\leq -165$ dBc
Anschlussmaßnorm Mating face standard		gem./accord. to IEC 60169-4
Kupplungsdrehmoment Coupling torque		25 ... 30 Nm
Innenleiter Inner conductor		Messing (Buchsen CuBe) versilbert brass silver plated (bushing CuBe)
Außenleiter Outer conductor		Messing versilbert brass silver plated
sonstige Metallteile other metal parts		Messing vernickelt brass nickel plated
Isolation Insulation		PTFE
Dichtung Sealing		Silikon silicone
Betriebstemperatur Operating temperature range		- 40 °C ... + 85 °C
Schutzgrad (gesteckter Zustand) Degree of protection (mated condition)		IP67



# TYP IV - MIT $\lambda/4$ LEITUNG UND GASENTLADUNGSABLEITER

## TYP IV - WITH QUARTER WAVELENGTH LINE AND GAS DISCHARGE ARRESTOR



BN 76 64 21

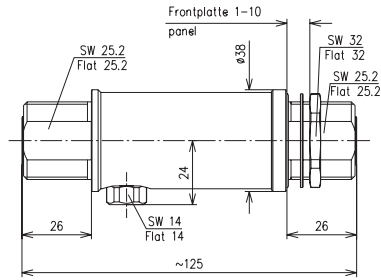

Querschnitt in Montageebene  
Cross section in mounting plane

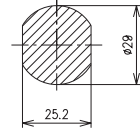

BN 75 64 95

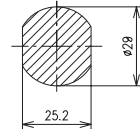
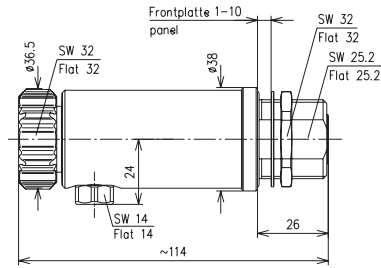

BN 76 64 22

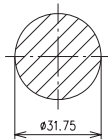
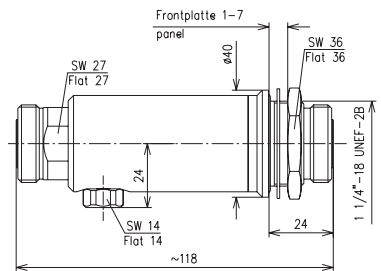

BN 76 64 23

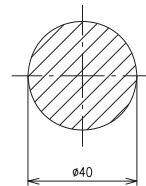
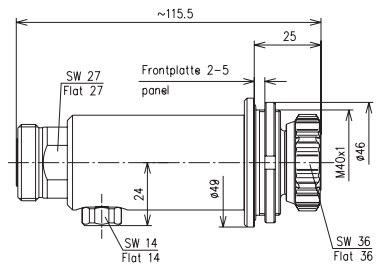







Diese Bauteile werden verwendet, um in Mobilfunk-sendeanlagen Gleichstrom in den Innenleiter eines koaxialen Kabels einzuspeisen.

Gleichzeitig werden diese Einspeisungen auch als Schutz für Überspannungen verwendet, wobei die Schutztechnik Hybrid mit senderseitigem DC-Block verwendet wird.

SPINNER liefert verschiedenste DC Einspeisungen, die für den jeweiligen Einsatz optimiert sind.

In diesem Katalog finden Sie zwei typische Beispiele:

- reine DC-Einspeisung
- DC-Einspeisung mit integriertem Modem nach AISG

Diese stellen nur eine kleine Auswahl unserer technischen Möglichkeiten dar. Deshalb bitten wir Sie, andere Ausführungen bei uns anzufragen. Wir helfen Ihnen gerne bei der Wahl der für Ihre Anwendung geeigneten Ausführung.

#### Vorteile

- hohe Gleichspannungs- und -strombelastung
- hohe HF-Anschlussleistung
- breitbandig niedriges VSWR
- niedrige Intermodulation

Optional erhältlich:

- Modem zur Übertragung von digitalen Signalen
- Modem Betriebsspannung 12 V oder 24 V DC
- DC-Durchgang

These components are used to inject DC current into the inner conductor of a coaxial cable of Mobile Communication transceiver systems.

Additionally, these Bias-Ts feature an integrated hybrid type surge arrester with a DC break in the transceiver line.

SPINNER supplies various types of Bias-Ts, optimised for your application.

In this catalogue two typical examples are shown:

- simple Bias-T
- Bias-T with built-in modem according to AISG

This is only a small selection of our technical capabilities. For other types please ask us. A wide selection of other types is available on request.

#### Advantages

- High DC voltage and current rating
- High RF power rating
- Broadband low VSWR
- Low intermodulation

Optionally available:

- Modem to transmit digital signals
- Modem operating voltage 12 V or 24 V DC
- DC-pass

## TYP V/VI - DC-EINSPEISUNG MIT ÜBERSPANNUNGSABLEITER



## TYP V/VI - BIAS-T WITH SURGE PROTECTOR

### Typische Daten ■ Typical Data

Koax-DC-Einspeisung mit DC-Block und Ableiter | Bias-T with DC break and arrestor

Frequenzbereich Frequency range		800 ... 2500 MHz
VSWR		≤ 1.12
Durchgangsdämpfung Insertion loss		≤ 0.05 dB
DC-Spannung DC voltage		± 60 V max.
Strombelastung bei 12 V Current rating at 12 V		6.4 A max.
zulässiger Ableitstoßstrom Allowed surge current		25 kA (8/20 µs)
Anschlüsse Connectors	RF/DC-Seite/Side (50 Ω) RF-Seite/Side (50 Ω) DC-Einspeisung/Connection	7-16 Stecker/Plug 7-16 Kuppler/Socket SMA Kuppler/Socket
Entkopplung AC-DC Isolation AC-DC	800 ... 2200 MHz > 2200 ... 2500 MHz	≥ 70 dB ≥ 60 dB
Intermodulation (IM3) 2 x 20 W		≤ -160 dBc
zulässige HF-Leistung RF power rating		≤ 750 W (850 MHz)



### Bestell-Nummer / Part Number

BN 75 64 98



## TYP V/VI - DC-EINSPEISUNG MIT ÜBERSPANNUNGSABLEITER

### TYP V/VI - BIAS-T WITH SURGE PROTECTOR

#### Typische Daten ■ Typical Data

Koax-DC-Einspeisung mit DC-Block, Feinschutz und Modem | Bias-T with DC break, fine protector and modem

Frequenzbereich Frequency range		800 ... 2170 MHz
VSWR		$\leq 1.15$
Durchgangsdämpfung Insertion loss		$\leq 0.1$ dB
DC-Spannung DC voltage		24 V ( 10 ... 30 V)
Strombelastung bei 12 V Current rating at 12 V		2 A max.
zulässiger Ableitstoßstrom Allowed surge current		10 kA (8/20 $\mu$ s)
Anschlüsse Connectors	RF/DC-Seite/Side (50 $\Omega$ ) RF-Seite/Side (50 $\Omega$ )	7-16 Stecker/Plug 7-16 Kuppler/Socket
Anschluss DC/Modem Connector DC/Modem		8-pol. Rundstecker m. Kontaktbuchsen 8 pin circular connector with female contacts
Intermodulation (IM3) 2 x 20 W		$\leq -160$ dBc
zulässige HF-Leistung RF power rating		$\leq 750$ W (850 MHz)



#### Bestell-Nummer / Part Number

BN 75 65 29



### COAXIAL SPLITTER & COUPLER



SPINNER bietet seinen Kunden extrem breitbandige Komponenten, die eine gemeinsame Nutzung eines Verteilersystems für alle Mobilfunkanwendungen im Frequenzbereich von 220 bis 2700 MHz – TETRA, GSM900, GSM1800, UMTS, WLAN und WiMAX erlauben.

Bei der Aufteilung von Mobilfunksignalen wie sie z.B. bei der Inhouse-Versorgung von Bürogebäuden oder Einkaufszentren benötigt wird, kommen drei unterschiedliche Verteilerkomponenten zum Einsatz:

**Symmetrische Verteiler** (Splitter) teilen ein Eingangssignal in zwei oder mehrere gleichartige Anteile auf.

**Unsymmetrische Verteiler** (Tapper) hingegen teilen ein Signal in zwei unterschiedlich große Anteile mit einem festgelegten Verteilerverhältnis.

Splitter und Tapper sind wichtige Bestandteile zur einfachen und gleichmäßigen Ansteuerung von Inhouse-Antennen.

**Richtkoppler** erlauben die Aufteilung eines Eingangssignals in zwei gleiche oder ungleiche Anteile. Dabei sind beide Ausgänge sehr stark voneinander entkoppelt. Darüber hinaus können mit einem Richtkoppler zwei Eingangssignale, auch bei unterschiedlichen Frequenzen, gemischt werden. Hierdurch bieten sie eine einfache und kostengünstige Lösung zur Zusammenschaltung zweier BTS-Signale.

SPINNER offers its customers components with an extremely broad range of use that allow you to use a common distributor system for all mobile communication applications in the frequency range between 220 and 2700 MHz – TETRA, GSM900, GSM1800, UMTS, WLAN and WiMAX.

When mobile communication signals are distributed, which is necessary for the in-house distribution in office buildings or shopping centres, three different distribution components are employed:

**Symmetric splitters** split up the incoming signal in two or more identical shares.

On the other hand **asymmetric distributors** (tappers) split up a signal in different shares with a defined distribution ratio.

Splitters and tappers are the key components required for the simple and smooth control of in-house antennas.

**Directional couplers** make it possible to separate an incoming signal in two identical or two different shares with the output signals being very effectively de-coupled from each other. Over and above a directional coupler can be used to combine two incoming signals, even when they are on different frequencies. Thus directional couplers offer a simple and cost-efficient solution for combining two BTS signals.

## COAXIAL SYMMETRIC SPLITTER

Bestell-Nummer Part Number	BN 81 82 57	BN 81 82 58	BN 53 15 92	BN 81 82 61
Anzahl der Ausgänge Number of outputs	2	2	3	4
Frequenzbereich Frequency range	870 ... 960 MHz	850 ... 2200 MHz		
VSWR am Eingang VSWR at input	≤ 1.1	≤ 1.15	≤ 1.22	≤ 1.22
Durchgangsdämpfung Insertion loss	≤ 3.2 dB	≤ 3.2 dB	≤ 5.0 dB	≤ 6.2 dB
Amplitudendifferenz Amplitude balance	≤ 0.1 dB	≤ 0.2 dB	≤ 0.35 dB	≤ 0.2 dB
Phasendifferenz Phase balance	0°	0°	≤ 27°	0°
Anschlussleistung Power rating	≤ 800 W	≤ 500 W	≤ 500 W	≤ 300 W
Intermodulation (IM3) 2 x 20 W	≤ -150 dBc; typ. ≤ -160 dBc			
Temperaturbereich Temperature range	-40 °C ... +55 °C			
Schutzgrad Degree of protection	IP65			
Anschlüsse (50 Ω) Connectors IEC 60169-4	Eingang/Input Ausgänge/Outputs		7-16 Stecker/Plug 7-16 Kuppler/Socket	
Gewicht Weight	ca./approx. 0.6 kg	ca./approx. 0.7 kg	ca./approx. 0.8 kg	ca./approx. 0.9 kg
Mast-/Wandhalterungen Mast/Wall mounting brackets	Teil des Lieferumfangs part of delivery	zu bestellen/to be ordered BN B0 80 57 / BN B0 80 54		

### ZUBEHÖR ■ ACCESSORIES

Bestell-Nummer / Part Number	
BN B0 80 57	Masthalterung Mast mounting
BN B0 80 54	Wandhalterung Wall mounting

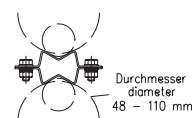
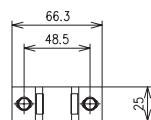

BN B0 80 57

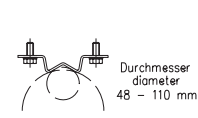
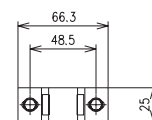

BN B0 80 54

## COAXIAL SYMMETRIC SPLITTER

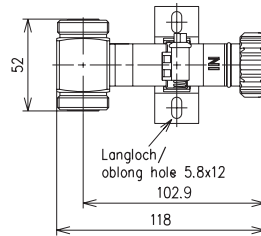

**Bestell-Nummer / Part Number**

BN 81 82 57

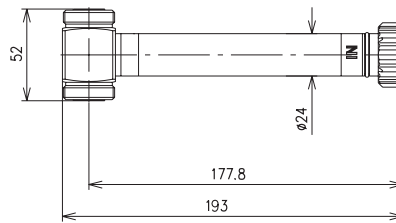

**Bestell-Nummer / Part Number**

BN 81 82 58

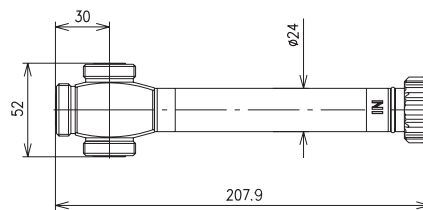

**Bestell-Nummer / Part Number**

BN 53 15 92

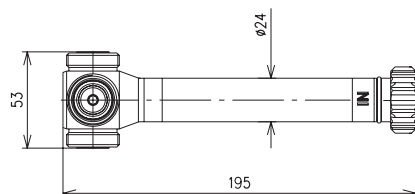

**Bestell-Nummer / Part Number**

BN 81 82 61

## COAXIAL SYMMETRIC SPLITTER

Bestell-Nummer Part Number	BN 81 82 89	BN 81 82 90	BN 81 82 91
Anzahl der Ausgänge Number of outputs	2	3	4
Frequenzbereich Frequency range	330 ... 2700 MHz		
VSWR am Eingang VSWR at input	≤ 1.2		
Durchgangsdämpfung Insertion loss	≤ 3.2 dB	≤ 5.0 dB	≤ 6.2 dB
Amplitudendifferenz Amplitude balance	≤ 0.3 dB	≤ 0.3 dB	≤ 0.5 dB
Phasendifferenz Phase balance	≤ 3°	≤ 3°	≤ 8°
Anschlussleistung Power rating	≤ 450 W		
Intermodulation (IM3) 2 x 20 W	≤ -160 dBc; typ. ≤ -165 dBc		
Temperaturbereich Temperature range	-40 °C ... +55 °C		
Schutzgrad Degree of protection	IP65		
Anschlüsse (50 Ω) Connectors IEC 60169-4	7-16 Kuppler/Socket		
Gewicht Weight	ca./approx. 1.0 kg	ca./approx. 1.1 kg	ca./approx. 1.2 kg
Mast-/Wandhalterungen Mast/Wall mounting brackets	Teil des Lieferumfangs part of delivery		



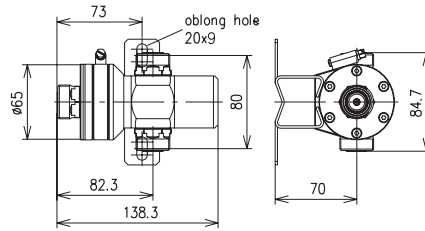

**Bestell-Nummer / Part Number**

BN 81 82 89

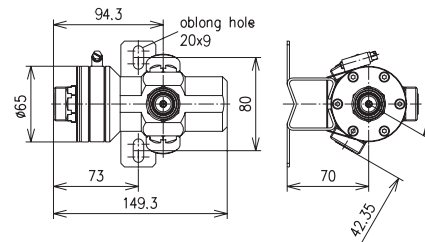

**Bestell-Nummer / Part Number**

BN 81 82 90

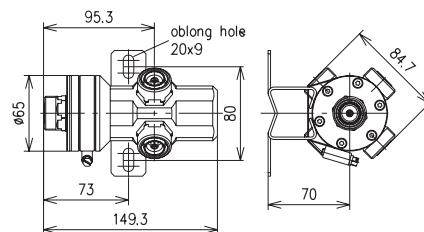

**Bestell-Nummer / Part Number**

BN 81 82 91

## COAXIAL UNSYMMETRIC SPLITTER

Bestell-Nummer Part Number	BN 81 82 42	BN 81 82 43	BN 81 82 44	BN 81 82 45	BN 81 82 46	BN 81 82 99	BN 81 82 48
Verteilungsverhältnis Splitting ratio	1:1/4:3/4	1:1/5:4/5	1:1/6:5/6	1:1/10:9/10	1:1/20:19/20	1:1/30:29/30	1:1/100:99/100
Frequenzbereich Frequency range	380 ... 1500 MHz 1710 ... 2700 MHz						
VSWR am Eingang VSWR at input	≤ 1.4	≤ 1.3					
Durchgangsdämpfung Insertion loss							
Nebenleitung/Secondary line	6.0 ± 1 dB	7.0 ± 1 dB	8.0 ± 1 dB	10.0 ± 1 dB	13.0 ± 1 dB	15.0 + 1 / - 2 dB	20.0 + 1 / - 2.5 dB
Hauptleitung/Main line	~ 1.25 dB	~ 1.0 dB	~ 1.0 dB	~ 0.5 dB	~ 0.2 dB	~ 0.15 dB	~ 0.1 dB
Anschlussleistung Power rating	≤ 500 W						
Intermodulation (IM3) 2 x 20 W	≤ -155 dBc; typ. ≤ -160 dBc						
Temperaturbereich Temperature range	-40 °C ... +70 °C						
Schutzgrad Degree of protection	IP65						
Anschlüsse (50 Ω) Connectors IEC 60169-4	7-16 Kuppler/Socket						
Gewicht Weight	ca./approx. 0.5 kg						
Mast-/Wandhalterungen Mast/Wall mounting brackets	zu bestellen/to be ordered BN B0 94 99						

### ZUBEHÖR ■ ACCESSORIES

#### Bestell-Nummer / Part Number

BN B0 94 99

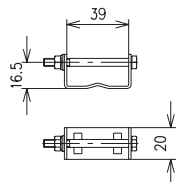

## COAXIAL UNSYMMETRIC SPLITTER

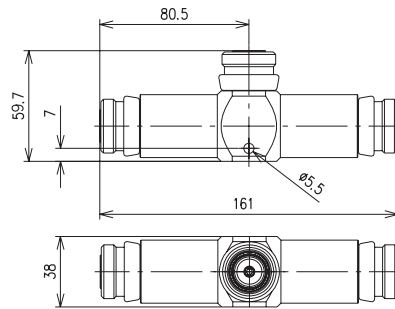

### Bestell-Nummer / Part Number

BN 81 82 42

BN 81 82 43

BN 81 82 44

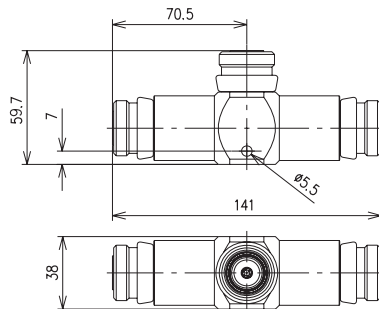

### Bestell-Nummer / Part Number

BN 81 82 45

BN 81 82 46

BN 81 82 99

BN 81 82 48

## COAXIAL DIRECTIONAL COUPLER

Bestell-Nummer Part Number	BN 75 33 81	BN 75 33 82	BN 75 33 83	BN 75 33 86	BN 75 33 84	BN 75 33 85
Bauform Style	H					
Frequenzbereich Frequency range	330 ... 520 MHz					
Koppeldämpfung Coupling	3.0 ± 0.3 dB	6.0 ± 0.5 dB	10.0 ± 0.5 dB	20.0 ± 0.5 dB	30.0 ± 0.5 dB	50.0 ± 0.5 dB
Directivity	≥ 30 dB					
VSWR	≤ 1.06					
Anschlussleistung Power rating	≤ 1000 W					
Temperaturbereich Temperature range	-40 °C ... +70 °C					
Schutzgrad Degree of protection	IP65					
Anschlüsse (50 Ω) Connectors IEC 60169-4	7-16 Kuppler/Socket					
Gewicht Weight	ca./approx. 1.4 kg					

Bestell-Nummer Part Number	BN 75 33 52	BN 75 33 48	BN 75 33 49	BN 75 33 53	BN 75 33 54
Bauform Style	H				X
Frequenzbereich Frequency range	800 ... 2500 MHz				
Koppeldämpfung Coupling	3.0 ± 0.25 dB	6.0 ± 0.5 dB	10.0 ± 0.5 dB	30.0 ± 1.0 dB	3.0 ± 0.25 dB
Directivity (800 ... 2200 MHz) (>2200 ... 2500 MHz)	≥ 30 dB (800 ... 2500 MHz)	≥ 30 dB ≥ 27 dB		≥ 30 dB (800 ... 2500 MHz)	≥ 30 dB ≥ 28 dB
VSWR (800 ... 2200 MHz) (>2200 ... 2500 MHz)	≤ 1.06 (800 ... 2500 MHz)	≤ 1.08 ≤ 1.15	≤ 1.10 ≤ 1.20	≤ 1.06 (800 ... 2500 MHz)	≤ 1.06 ≤ 1.08
Anschlussleistung Power rating	≤ 1000 W				
Intermodulation (IM3) 2 x 20 W	≤ -160 dBc; typ. ≤ -165 dBc				
Temperaturbereich Temperature range	-40 °C ... +70 °C				
Schutzgrad Degree of protection	IP65				
Anschlüsse (50 Ω) Connectors IEC 60169-4	7-16 Kuppler/Socket				
Gewicht Weight	ca./approx. 1.2 kg				

## COAXIAL DIRECTIONAL COUPLER

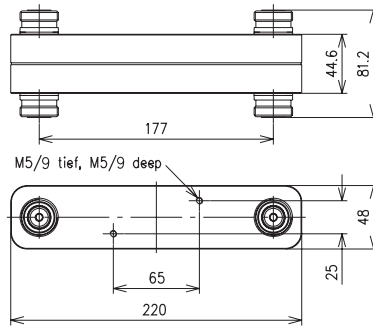
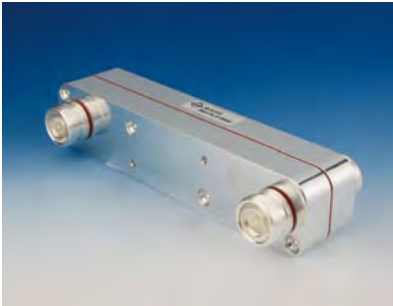

### Bestell-Nummer / Part Number

BN 75 33 81

BN 75 33 82

BN 75 33 83

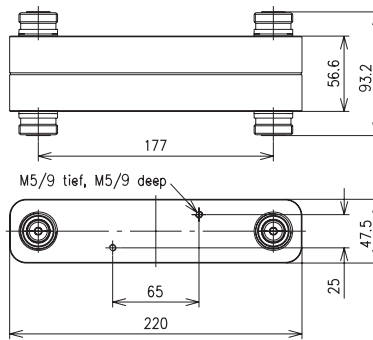

### Bestell-Nummer / Part Number

BN 75 33 86

BN 75 33 84

BN 75 33 85

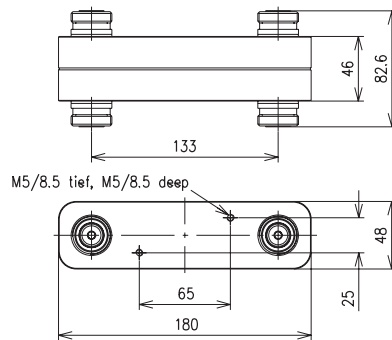

### Bestell-Nummer / Part Number

BN 75 33 52

BN 75 33 48

BN 75 33 49

BN 75 33 53

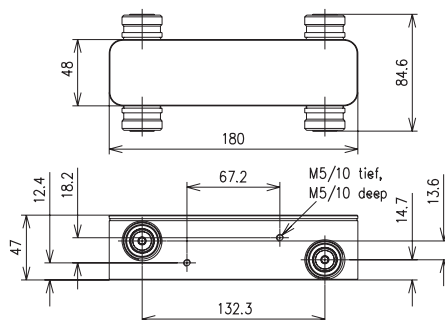

### Bestell-Nummer / Part Number

BN 75 33 54

## COAXIAL DIRECTIONAL COUPLER

Hybridcombiner mit IM-armem Abschlußwiderstand ■ Hybrid combiner with low IM load

Bestell-Nummer Part Number	BN 57 30 45
Frequenzbereich Frequency range	800 ... 2170 MHz
Koppeldämpfung Coupling	3.0 ± 0.5 dB
Directivity	≥ 27 dB
VSWR	≤ 1.15
Anschlussleistung pro Eingang Power rating per input	≤ 100 W
Intermodulation (IM3) 2 x 20 W Eingänge/Inputs Ausgänge/Outputs	≤ -155 dBC; typ. -160 dBC ≤ -143 dBC; typ. -150 dBC
Temperaturbereich Temperature range	-40 °C ... +55 °C
Schutzgrad Degree of protection	IP65
Anschlüsse (50 Ω) Connectors IEC 60169-4	7-16 Kuppler/Socket
Gewicht Weight	ca./approx. 4.2 kg
Mast- / Wandhalterung Mast / Wall mounting bracket	Teil des Lieferumfangs part of delivery

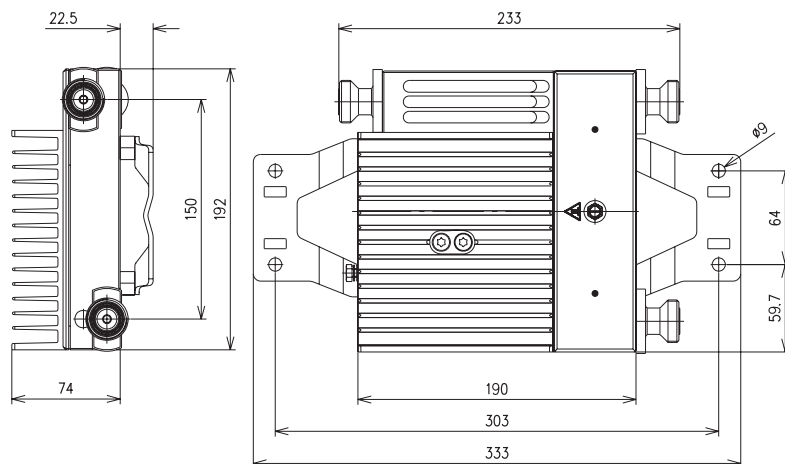
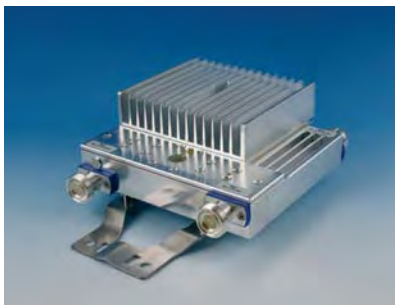



Widerstände übernehmen häufig die Funktion einer Antenne während der Test- oder Einmessphase einer Mobilfunk-Basisstation.

Sie absorbieren dabei die HF-Energie und wandeln diese in Wärme um. Die maximale Belastbarkeit hängt bei den in diesem Katalog dargestellten Typen hauptsächlich von der Baugröße des Kühlkörpers bzw. der Umgebungstemperatur ab.

SPINNER-Widerstände verfügen über ein hervorragendes VSWR über den gesamten Einsatzfrequenzbereich.

Neben den mit resistiven Elementen aufgebauten Versionen bieten wir auch Low-IM-Widerstände an. Diese verwenden ein langes, dämpfungsbehaftetes Kupfer-Kabel, um die angeschlossene HF-Leistung zu absorbieren.

Low-IM-Widerstände erreichen garantierte -160 dBc Intermodulationsabstand und eignen sich damit ideal für alle Mobilfunkanwendungen.

Dämpfungsglieder sind vom Aufbau und der Wirkungsweise Widerständen sehr ähnlich, absorbieren aber nur einen Teil der eingespeisten Leistung. Sie können damit zur Simulation eines Empfangsignals oder zur vorübergehenden Leistungsbegrenzung, auch einzelner BTS-Sektoren verwendet werden.

Auch Dämpfungsglieder bieten wir als Low-IM-Versionen mit einem Intermodulationsabstand von garantierten -163 dBc an.

During the testing and tuning phase of a mobile communication ground station resistors often fulfill the function of an antenna.

They absorb the RF energy and transform it into heat. With the resistor types presented in this catalogue the main factors influencing the maximum load capacity include the size of the cooling body and the ambient temperature.

Spinner resistors feature an excellent VSWR throughout their whole frequency range.

Besides the versions based on resistive elements we also offer Low-IM resistors. They use a long copper cable with inherent attenuation in order to absorb the RF energy from the connected system.

Low-IM resistors guarantee an intermodulation value of -160 dBc, which makes them ideal products for all mobile communication applications.

Attenuation links are very similar to resistors in terms of their structure and function, but they absorb only part of the input power. So they can be used for simulating a received signal or for temporary power limitation of individual BTS sectors.

We also offer our attenuation links as Low-IM versions with a guaranteed intermodulation value of -163 dBc.

## COAXIAL LOADS

### KOAXIALE IM-ARME WIDERSTÄNDE ■ COAXIAL LOW INTERMODULATION LOADS

Bestell-Nummer Part Number	BN 53 42 79	BN 53 42 80	BN 53 42 77
Frequenzbereich Frequency range	800 ... 3000 MHz		
Intermodulation (IM3) 2 x 20 W	≤ -160 dBc; typ. ≤ -165 dBc		
VSWR	≤ 1.15; typ. ≤ 1.11		
Anschlussleistung Power rating	≤ 50 W	≤ 100 W	≤ 150 W
Temperaturbereich Temperature range	-5 °C ... +55 °C		
Schutzgrad Degree of protection	IP20		
Anschlüsse (50 Ω) Connectors IEC 60169-4	7-16 Kuppler/Socket		
Gewicht Weight	ca./approx. 2.0 kg	ca./approx. 2.8 kg	ca./approx. 4.1 kg



BN 53 42 79

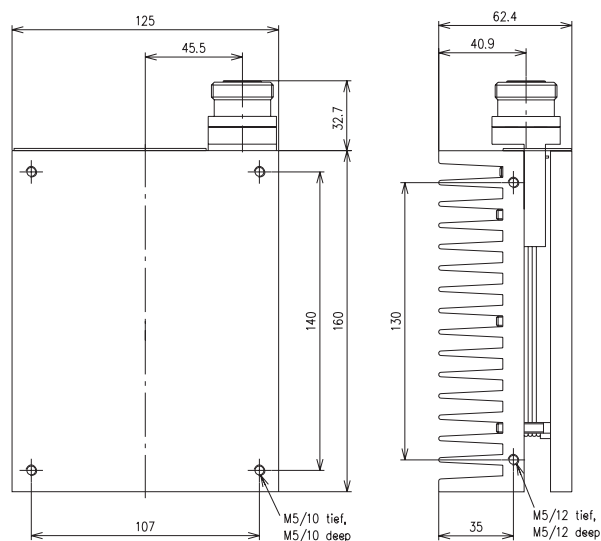



## COAXIAL LOADS

### KOAXIALE IM-ARME WIDERSTÄNDE ■ COAXIAL LOW INTERMODULATION LOADS

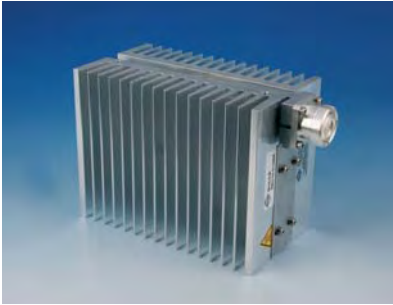

BN 53 42 80

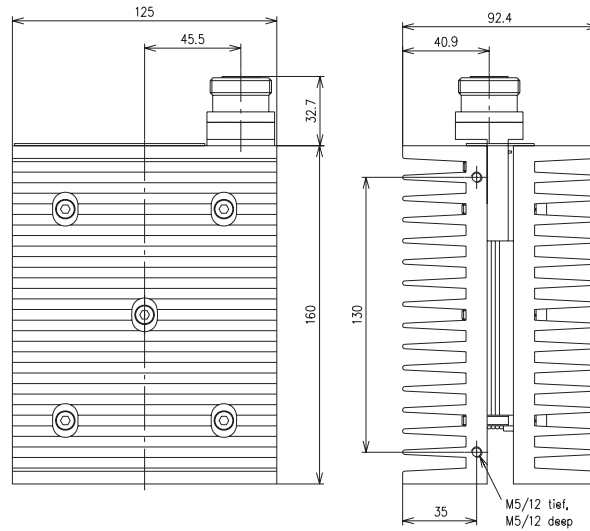

BN 53 42 77

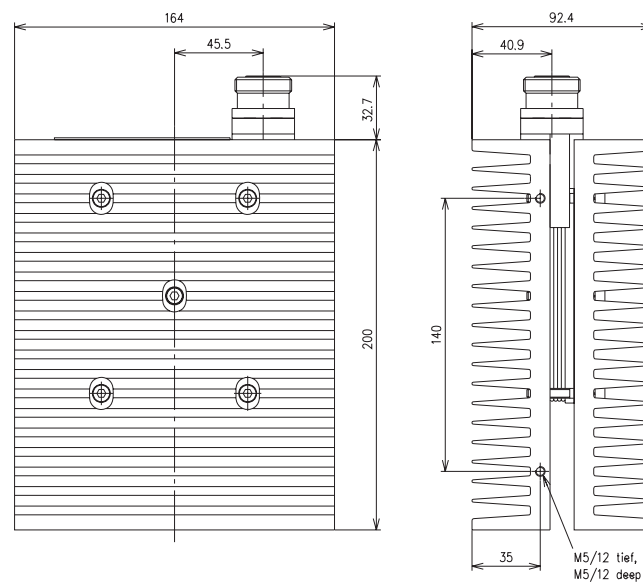

## COAXIAL LOADS

### KOAXIALE STANDARD WIDERSTÄNDE ■ COAXIAL STANDARD LOADS

Bestell-Nummer Part Number	BN 53 17 12	BN 53 17 27	BN 53 12 21	BN 53 12 25	BN 52 77 57
Frequenzbereich Frequency range	0 ... 5000 MHz				
VSWR	$\leq 1.06$ (0 ... 1000 MHz) $\leq 1.11$ (>1000 ... 2000 MHz) $\leq 1.17$ (>2000 ... 5000 MHz)				
Anschlussleistung Power rating	$\leq 5$ W		$\leq 10$ W		$\leq 25$ W
Temperaturbereich Temperature range	-40 °C ... +25 °C volle Leistung/full power +25 °C ... +125 °C linear absinkend bis 25% derated linearly to 25%				
Schutzgrad Degree of protection	IP40				
Anschlüsse (50 Ω) Connectors IEC 60169-4 IEC 60169-16	7-16 Stecker/Plug	N Stecker/Plug	N Stecker/Plug	7-16 Stecker/Plug	7-16 Stecker/Plug
Gewicht Weight	ca./approx. 0.05 kg		ca./approx. 0.1 kg		ca./approx. 0.15 kg

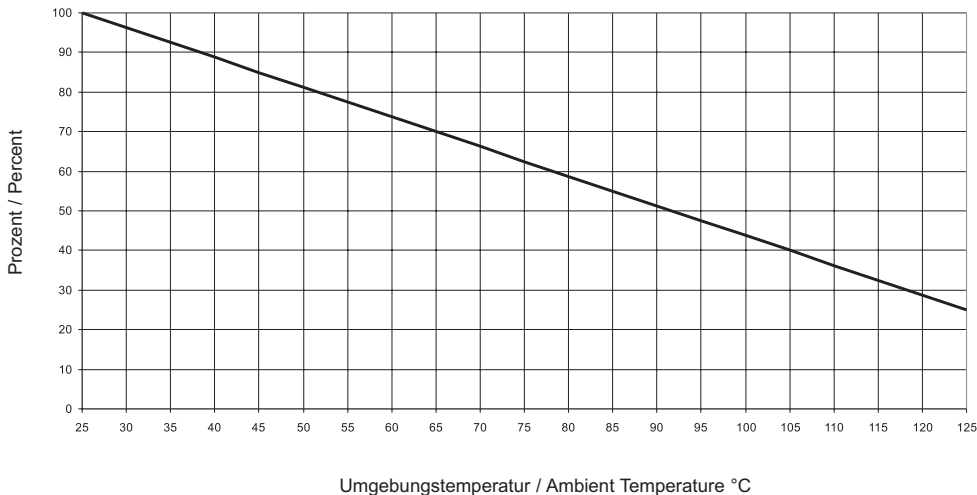

Reduzierung der Anschlussleistung  
Derating of power

## COAXIAL LOADS

### KOAXIALE STANDARD WIDERSTÄNDE ■ COAXIAL STANDARD LOADS



BN 53 17 12

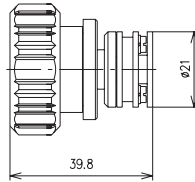

BN 53 17 27

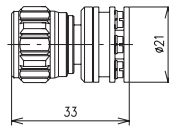

BN 53 12 21

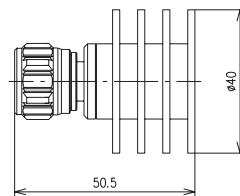

BN 53 12 25

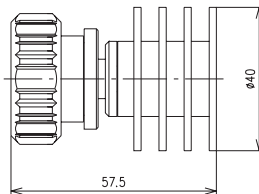

BN 52 77 57

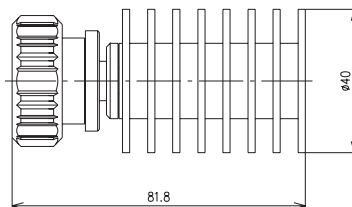

## COAXIAL LOADS

### KOAXIALE STANDARD WIDERSTÄNDE ■ COAXIAL STANDARD LOADS

Bestell-Nummer Part Number	BN 53 77 84	BN 53 77 82	BN 53 77 86
Frequenzbereich Frequency range	0 ... 3000 MHz		
VSWR	$\leq 1.10$ (0 ... 1000 MHz) $\leq 1.13$ (>1000 ... 2200 MHz) $\leq 1.20$ (>2200 ... 3000 MHz)	$\leq 1.10$ (0 ... 2000 MHz) $\leq 1.13$ (>2000 ... 3000 MHz)	
Anschlussleistung Power rating	$\leq 50$ W	$\leq 50$ W	$\leq 100$ W
Temperaturbereich Temperature range	-40 °C ... +40 °C volle Leistung/full power +40 °C ... +100 °C linear absinkend bis 0% derated linearly to 0%		
Schutzgrad Degree of protection	IP65	IP40	IP40
Anschlüsse (50 Ω) Connectors IEC 60169-4	7-16 Stecker/Plug		
Gewicht Weight	ca./approx. 0.8 kg	ca./approx. 0.8 kg	ca./approx. 1.2 kg

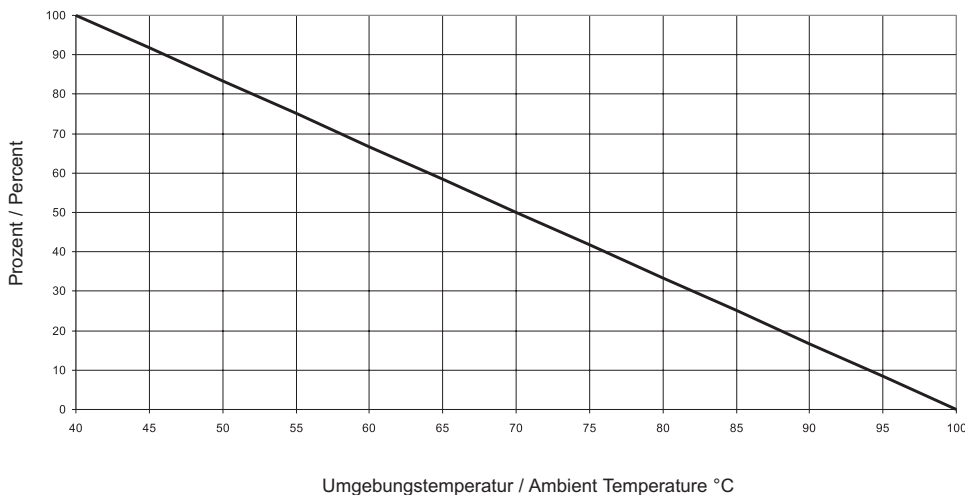

Reduzierung der Anschlussleistung  
Derating of power

## COAXIAL LOADS

### KOAXIALE STANDARD WIDERSTÄNDE ■ COAXIAL STANDARD LOADS



BN 53 77 84

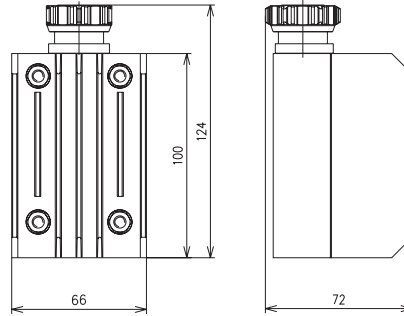

BN 53 77 82

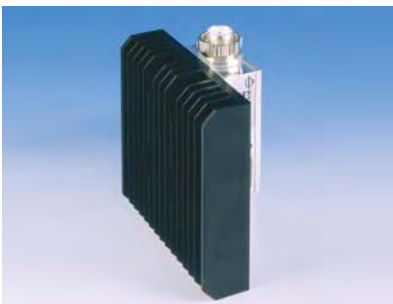
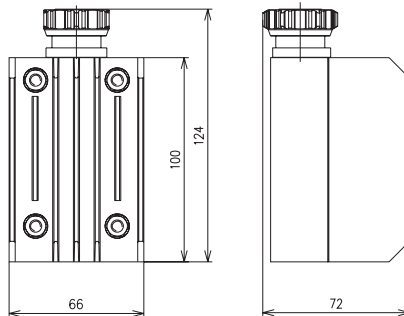

BN 53 77 86

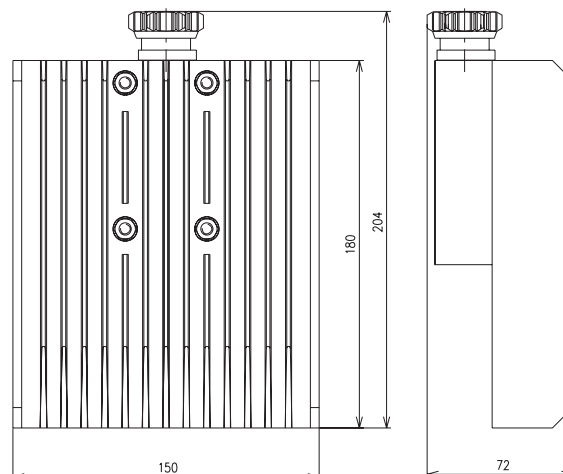

## COAXIAL ATTENUATORS

### IM-ARME DÄMPFUNGSGLIEDER ■ LOW INTERMODULATION ATTENUATORS

Bestell-Nummer Part Number	BN 74 51 44	BN 74 51 46
Frequenzbereich Frequency range	890 ... 960 MHz	1710 ... 1880 MHz
Intermodulation (IM3) 2 x 20 W	$\leq -163$ dBc; typ. $\leq -165$ dBc	
Dämpfung Attenuation	$3.0 \pm 0.5$ dB	
VSWR	$\leq 1.2$ ; typ. $\leq 1.15$	
Anschlussleistung Power rating	$\leq 50$ W	
Temperaturbereich Temperature range	$-5$ °C ... $+55$ °C	
Schutzgrad Degree of protection	IP20	
Anschlüsse (50 $\Omega$ ) Connectors IEC 60169-4	7-16 Kuppler/Socket	
Gewicht Weight	ca./approx. 0.5 kg	

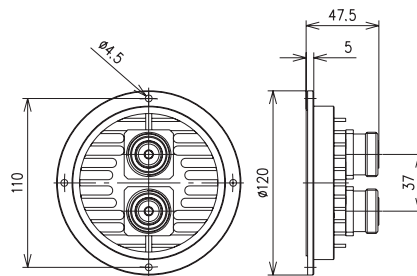

Bestell-Nummer / Part Number
BN 74 51 44
BN 74 51 46

### KOAXIALE STANDARD DÄMPFUNGSGLIEDER ■ COAXIAL STANDARD ATTENUATORS

Bestell-Nummer Part Number	BN 52 86 22	BN 52 86 24	BN 52 86 26	BN 52 86 27
Frequenzbereich Frequency range	0 ... 12.4 GHz			
Dämpfung Attenuation	3 dB	6 dB	10 dB	20 dB
Dämpfungstoleranz Accuracy	0 ... 8 GHz ± 0.2 dB	± 0.2 dB	± 0.3 dB	± 0.5 dB
VSWR	0 ... 4 GHz > 4 ... 8 GHz	≤ 1.15 ≤ 1.27		
Anschlussleistung Power rating	≤ 10 W	≤ 6.5 W	≤ 5 W	≤ 5 W
Temperaturbereich Temperature range	-40 °C ... +25 °C volle Leistung/full power +25 °C ... +80 °C linear absinkend bis 25% derated linearly to 25%			
Schutzgrad Degree of protection	IP40			
Anschlüsse (50 Ω) Connectors IEC 60169-16	N Stecker/Plug N Kuppler/Socket			
Gewicht Weight	ca./approx. 0.1 kg			

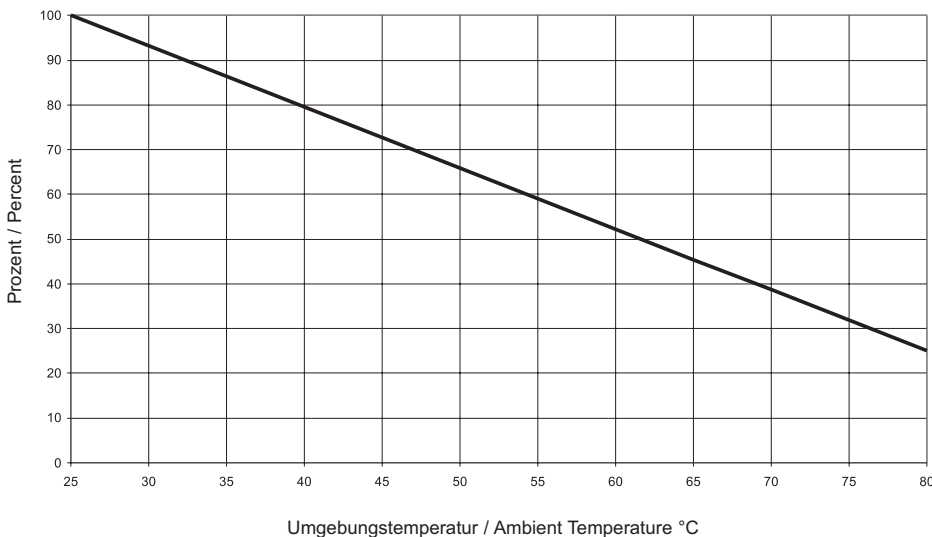

Reduzierung der Anschlussleistung  
Derating of power

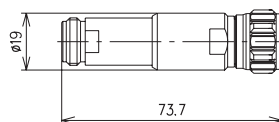

#### Bestell-Nummer / Part Number

BN 52 86 22

BN 52 86 24

BN 52 86 26

BN 52 86 27

## COAXIAL ATTENUATORS

### KOAXIALE STANDARD DÄMPFUNGSGLIEDER ■ COAXIAL STANDARD ATTENUATORS

Bestell-Nummer Part Number	BN 53 43 61	BN 53 43 62	BN 53 43 63	BN 53 43 64
Frequenzbereich Frequency range	0 ... 2.2 GHz			
Dämpfung Attenuation	3 dB	6 dB	10 dB	20 dB
Dämpfungstoleranz Accuracy	± 0.2 dB	± 0.2 dB	± 0.3 dB	± 0.5 dB
VSWR	0 ... 1 GHz ≤ 1.04 > 1 ... 2 GHz ≤ 1.06 > 2 ... 2.2 GHz ≤ 1.08			
Anschlussleistung Power rating	≤ 10 W	≤ 6.5 W	≤ 5 W	≤ 5 W
Temperaturbereich Temperature range	-40 °C ... +25 °C volle Leistung/full power +25 °C ... +125 °C linear absinkend bis 25% derated linearly to 25%			
Schutzgrad Degree of protection	IP65			
Anschlüsse (50 Ω) Connectors IEC 60169-4	7-16 Stecker/Plug 7-16 Kuppler/Socket			
Gewicht Weight	ca./approx. 0.12 kg			

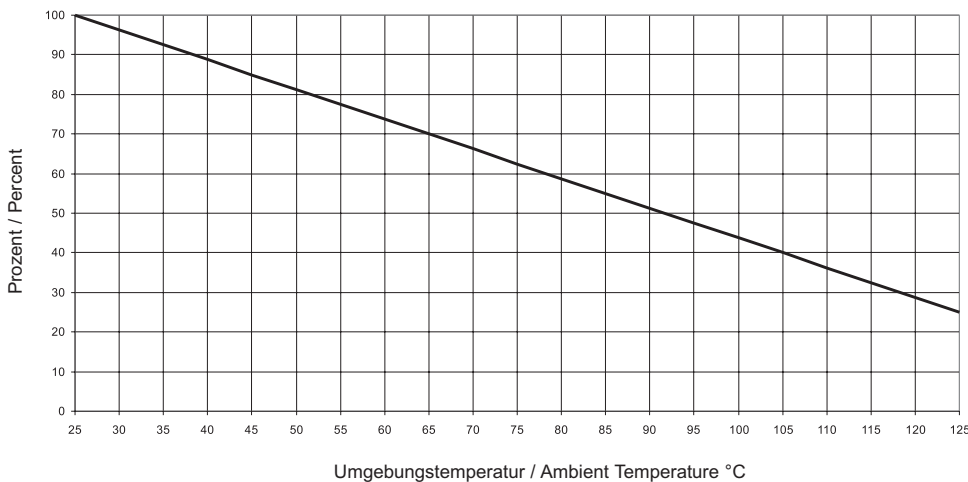

Reduzierung der Anschlussleistung  
Derating of power

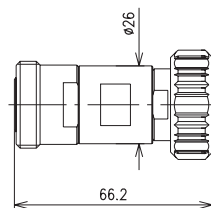

#### Bestell-Nummer / Part Number

BN 53 43 61

BN 53 43 62

BN 53 43 63

BN 53 43 64



### KOAXIALE STANDARD DÄMPFUNGSGLIEDER ■ COAXIAL STANDARD ATTENUATORS

Bestell-Nummer Part Number	BN 74 53 80	BN 74 53 82	BN 74 53 83	BN 74 53 84
Frequenzbereich Frequency range	0 ... 5 GHz			
Dämpfung Attenuation	3 dB	6 dB	10 dB	20 dB
Dämpfungstoleranz Accuracy	0 ... 4 GHz > 4 ... 5 GHz	± 0.2 dB ± 0.3 dB	± 0.2 dB ± 0.3 dB	± 0.5 dB ± 0.5 dB
VSWR	0 ... 1 GHz > 1 ... 2 GHz > 2 ... 3 GHz > 3 ... 4 GHz > 4 ... 5 GHz	≤ 1.08 ≤ 1.13 ≤ 1.22 ≤ 1.35 ≤ 1.44		
Anschlussleistung Power rating	≤ 50 W	≤ 30 W	≤ 25 W	≤ 25 W
Temperaturbereich Temperature range	-40 °C ... +25 °C volle Leistung/full power +25 °C ... +125 °C linear absinkend bis 25% derated linearly to 25%			
Schutzgrad Degree of protection	IP65			
Anschlüsse (50 Ω) Connectors IEC 60169-16	N Stecker/Plug N Kuppler/Socket			
Gewicht Weight	ca./approx. 0.3 kg			

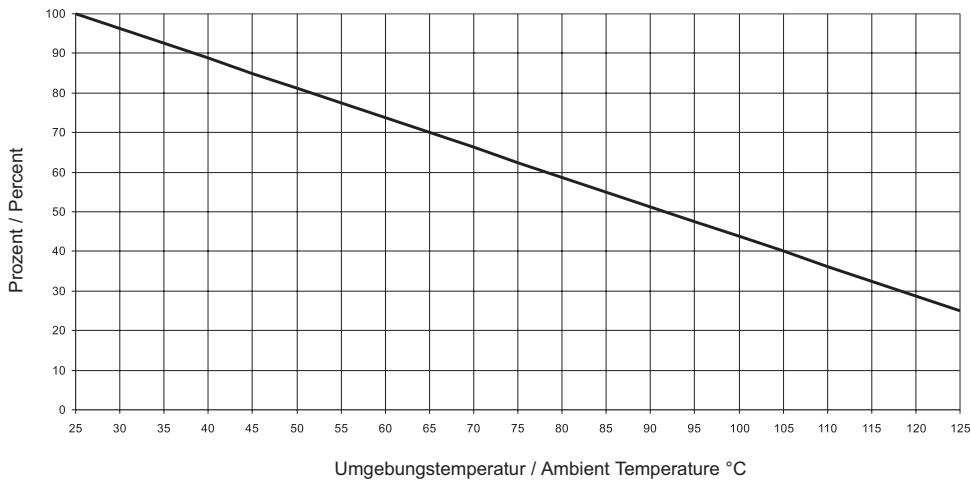

Reduzierung der Anschlussleistung  
Derating of power

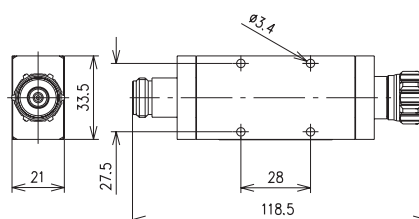

#### Bestell-Nummer / Part Number

BN 74 53 80

BN 74 53 82

BN 74 53 83

BN 74 53 84

## COAXIAL ATTENUATORS

### KOAXIALE STANDARD DÄMPFUNGSGLIEDER ■ COAXIAL STANDARD ATTENUATORS

Bestell-Nummer Part Number	BN 74 51 50	BN 74 51 52	BN 74 51 53	BN 74 51 54
Frequenzbereich Frequency range	0 ... 5 GHz			
Dämpfung Attenuation	3 dB	6 dB	10 dB	20 dB
Dämpfungstoleranz Accuracy	0 ... 4 GHz > 4 ... 5 GHz	± 0.2 dB ± 0.3 dB	± 0.2 dB ± 0.3 dB	± 0.5 dB ± 0.5 dB
VSWR	0 ... 1 GHz > 1 ... 2 GHz > 2 ... 3 GHz > 3 ... 4 GHz > 4 ... 5 GHz	≤ 1.08 ≤ 1.13 ≤ 1.22 ≤ 1.35 ≤ 1.44		
Anschlussleistung Power rating	≤ 50 W	≤ 30 W	≤ 25 W	≤ 25 W
Temperaturbereich Temperature range	-40 °C ... +25 °C volle Leistung/full power +25 °C ... +125 °C linear absinkend bis 25% derated linearly to 25%			
Schutzgrad Degree of protection	IP65			
Anschlüsse (50 Ω) Connectors IEC 60169-4	7-16 Stecker/Plug 7-16 Kuppler/Socket			
Gewicht Weight	ca./approx. 0.3 kg			

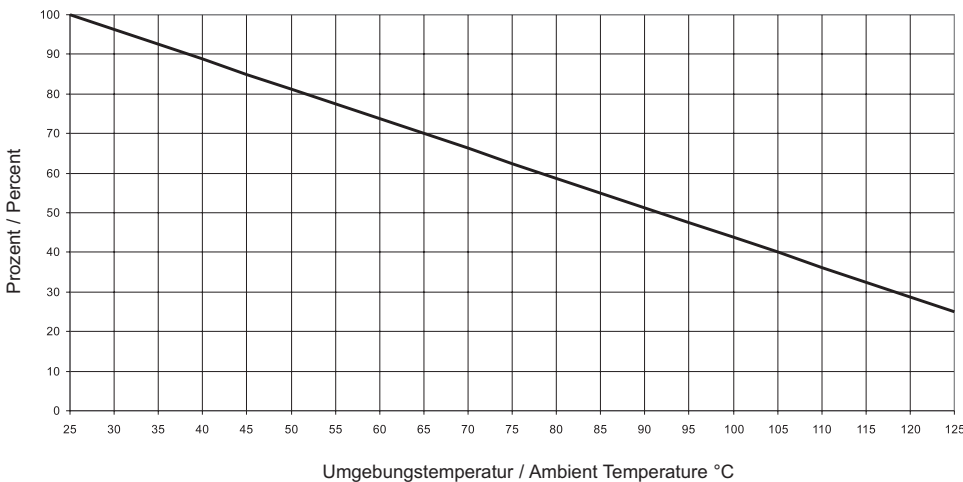

Reduzierung der Anschlussleistung  
Derating of power

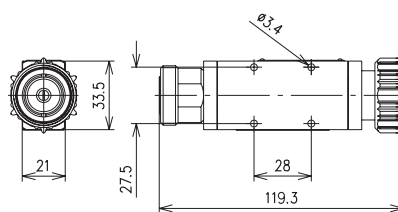

Bestell-Nummer / Part Number
BN 74 51 50
BN 74 51 52
BN 74 51 53
BN 74 51 54

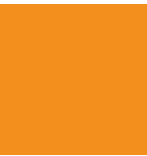

## COAXIAL DC BREAK

DC-Blöcke verhindern die Ausbreitung von Gleichströmen oder Signalen mit niedrigen Übertragungsfrequenzen bei einer gleichzeitig ungehinderten HF-Übertragung.

SPINNER liefert zwei Arten von DC-Blöcken:

- Typen mit aufgetrenntem Innen- und Außenleiter: Diese werden unter anderem häufig zur Vermeidung von ungewünschten induzierten Spannungen, wie sie z.B. durch die Starkstromkabel bei Strahlungskabeln im U-Bahn-Bereich entstehen, verwendet.
- Typen mit ausschließlicher Innenleiter-Trennung: Diese finden ihre Anwendung hauptsächlich bei der Abschirmung von Antennen oder Basisstationen vor gezielt am Innenleiter eingespeisten niederfrequenten Signalen zur Steuerung von Mobilfunkantennen bzw. der Stromversorgung von Antennenvorverstärkern.

DC blocks prevent the propagation of direct current or of signals with low transmission frequencies while allowing RF transmission to proceed smoothly at the same time.

SPINNER delivers two types of DC blocks:

- Types with open inner and outer conductor: They are mainly used for preventing undesirable induced voltage, e. g. by high power cables and signal cables in underground train systems.
- Types with open inner conductor only: They are mainly used for shielding antennas or ground stations from low-frequency signals deliberately fed in for controlling mobile communication antennas or for the power supply of antenna pre-amplifiers.

Bestell-Nummer Part Number	BN 75 64 86	BN 75 64 30	BN 95 08 15
Bauform Configuration	nur Innenleiter aufgetrennt only inner conductor separated	Innen- und Außenleiter aufgetrennt inner and outer conductor separated	
Frequenzbereich Frequency range	800 ... 2500 MHz	100 ... 6000 MHz	
Intermodulation (IM3) 2 x 20 W	≤ -160 dBc; typ. ≤ -165 dBc	-	
Durchgangsdämpfung Insertion loss	≤ 0.1dB	≤ 0.15 dB (100 ... 1500 MHz) ≤ 0.20 dB (>1500 ... 4000 MHz) ≤ 0.25 dB (>4000 ... 6000 MHz)	
Betriebsgleichspannung Operating DC voltage	≤ 1000 V		
VSWR	≤ 1.16	≤ 1.06 (100 ... 1500 MHz) ≤ 1.16 (>1500 ... 4000 MHz) ≤ 1.22 (>4000 ... 6000 MHz)	
Anschlussleistung Power rating	≤ 750 W bei/at 850 MHz	≤ 200 W	
Temperaturbereich Temperature range	-40 °C ... +55 °C		
Schutzgrad Degree of protection	IP65	IP40	
Anschlüsse (50 Ω) Connectors IEC 60169-4 IEC 60169-16	7-16 Stecker/Plug 7-16 Kuppler/Socket		N Stecker/Plug N Kuppler/Socket
Gewicht Weight	ca./approx. 0.3 kg		

COAXIAL DC BREAK



BN 75 64 86

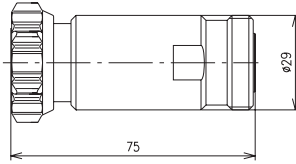

BN 75 64 30

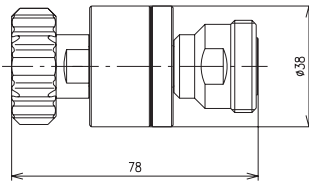

BN 95 08 15

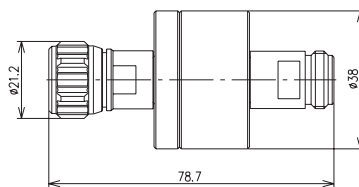

### COAXIAL FILTERS



Der ständig wachsende Bedarf an Frequenzbändern in der Telekommunikation führt zu immer enger nebeneinander liegenden Sende- und Empfangsfrequenzen und damit vermehrt zu unerwünschten gegenseitigen Beeinflussungen und Störungen.

Dies führt zur Reduzierung der Systemleistung und letztendlich zu vermehrten Gesprächsverlusten. Besonders kritisch ist es, wenn nahe aneinander liegende Bänder am gleichen Standort gesendet bzw. empfangen werden.

SPINNER liefert hierfür mit einer Vielzahl von Bandsper-, Bandpass-, Tiefpass- oder Hochpassfiltern die passenden Lösungen.

Die Filter sind auf geringst mögliche Dämpfungen im Durchlassbereich entwickelt. Der unvermeidbare Verlust von Nutzleistung (0,5 dB Dämpfung entsprechen bereits mehr als 10% Leistungsverlust) wird hierdurch auf ein Minimum reduziert. Darüber hinaus zeichnen sich unsere Filter durch hohe Sperrdämpfungen sowie steile Filterflanken aus.

Since the demand for frequency bands in telecommunication keeps growing continuously the transmission and reception frequencies are getting closer all the time, causing more and more undesirable mutual interference and noise.

This reduces the system power and finally results in more call interruptions. It is most critical when bands which are close together are transmitted and received by the same station.

SPINNER delivers a broad variety of stop band, band pass, low pass and high pass filters to ensure suitable solutions.

The filters have been designed for the lowest possible attenuation in the pass band. This helps minimise the inevitable loss of useful power (0.5 dB of attenuation are already equivalent to more than a 10% power loss). In addition our filters stand out for high stop band attenuation and steep filter edges.

**COAXIAL FILTERS**
**KOAXIALE TIEFPASS FILTER ■ COAXIAL LOW-PASS FILTER**

Bestell-Nummer Part Number	BN 61 63 31	BN 61 64 39	BN 61 63 95
Durchlassbereich Pass band	0 ... 500 MHz	0 ... 614 MHz	0 ... 960 MHz
Durchlassdämpfung Pass band attenuation	≤ 0.2 dB	≤ 0.2 dB	≤ 0.1 dB
Sperrdämpfung Stop band attenuation	≥ 45 dB (800 ... 876 MHz) ≥ 55 dB (> 876 ... 2200 MHz)	≥ 30 dB (800 ... 860 MHz) ≥ 40 dB (> 860 ... 960 MHz) ≥ 70 dB (1710 ... 2170 MHz)	≥ 50 dB (1710 ... 1880 MHz) ≥ 60 dB (1920 ... 2170 MHz)
VSWR	≤ 1.25 (0 ... 380 MHz) ≤ 1.14 (> 380 ... 500 MHz)	≤ 1.40 (0 ... 380 MHz) ≤ 1.15 (> 380 ... 614 MHz)	≤ 1.2
Anschlussleistung Power rating	≤ 150 W	≤ 150 W	≤ 750 W
Intermodulation (IM3) 2 x 20 W	≤ -150 dBc; typ. ≤ -160 dBc		
Temperaturbereich Temperature range	-40 °C ... +65 °C		
Schutzgrad Degree of protection	IP65		
Mast- oder Wandhalterung Mast or wall mounting brackets	im Lieferumfang enthalten part of delivery		zu bestellen/to be ordered BN B0 76 91
Anschlüsse (50 Ω) Connectors IEC 60169-4	7-16 Kuppler/Socket		7-16 Stecker/Plug 7-16 Kuppler/Socket
Gewicht Weight	ca./approx. 1.4 kg		ca./approx. 0.6 kg

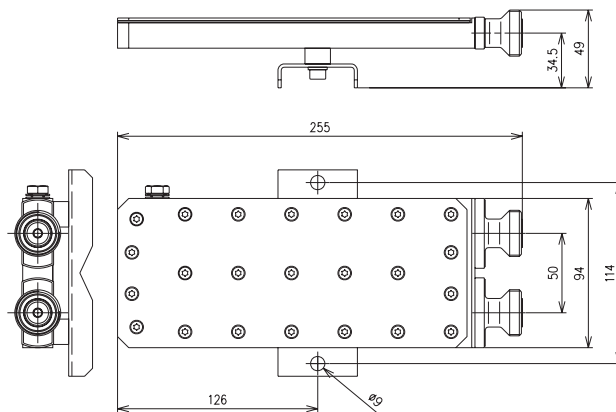
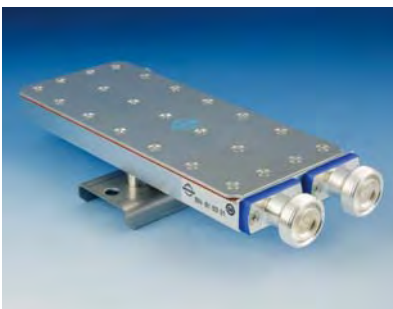
**Bestell-Nummer  
Part Number**

BN 61 63 31

BN 61 64 39

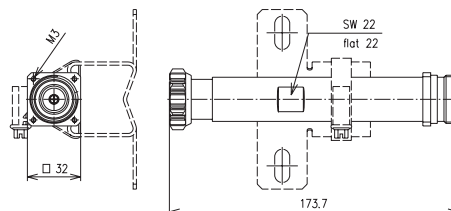
**Bestell-Nummer  
Part Number**

BN 61 63 95

BN B0 76 91

## COAXIAL FILTERS

### KOAXIALE BANDPASS FILTER ■ COAXIAL BAND PASS FILTER

Bestell-Nummer Part Number	BN 61 64 30	BN 61 64 31
Durchlassbereich Pass band	390... 395 MHz	380... 385 MHz
Durchlassdämpfung Pass band attenuation	≤ 0.5 dB	
Sperrdämpfung Stop band attenuation	≥ 30 dB (380 ... 385 MHz) ≥ 50 dB (890 ... 960 MHz)	≥ 30 dB (390 ... 395 MHz) ≥ 50 dB (890 ... 960 MHz)
VSWR	≤ 1.25	
Anschlussleistung Power rating	≤ 200 W	
Temperaturbereich Temperature range	-5 °C ... +60 °C	
Intermodulation (IM3) 2 x 20 W	-	
Schutzgrad Degree of protection	IP54	
Mast- oder Wandhalterung Mast or wall mounting brackets	zu bestellen/to be ordered BN B0 77 87	
Anschlüsse (50 Ω) Connectors IEC 60169-4	7-16 Kuppler/Socket	
Gewicht Weight	ca./approx. 1.7 kg	

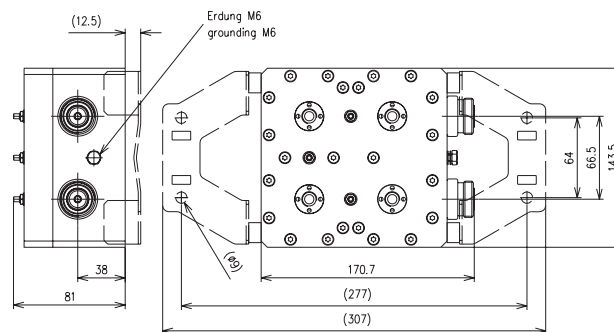
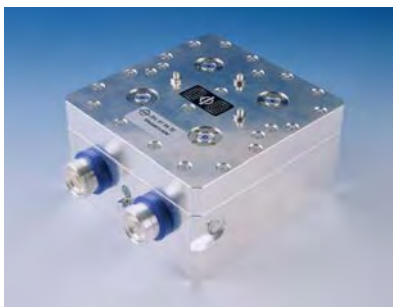

#### Bestell-Nummer Part Number

BN 61 64 30

BN 61 64 31

BN B0 77 87



**KOAXIALE BANDPASS FILTER ■ COAXIAL BAND PASS FILTER**

Bestell-Nummer Part Number	BN 61 63 96	BN 61 63 98
Durchlassbereich Pass band	1710...1880 MHz	1920...2170 MHz
Durchlassdämpfung Pass band attenuation	≤ 0.3 dB	≤ 0.5 dB
Sperrdämpfung Stop band attenuation	≥ 60 dB (890 ... 960 MHz) ≥ 30 dB (1920 ... 2500 MHz)	≥ 40 dB (1710 ... 1880 MHz)
VSWR	≤ 1.2	≤ 1.25
Anschlussleistung Power rating	≤ 100 W	
Temperaturbereich Temperature range	-40 °C ... +65 °C	
Intermodulation (IM3) 2 x 20 W	≤ -150 dBc; typ. ≤ -160 dBc	
Schutzgrad Degree of protection	IP65	
Mast- oder Wandhalterung Mast or wall mounting brackets	zu bestellen/to be ordered BN B0 89 62	
Anschlüsse (50 Ω) Connectors IEC 60169-4	7-16 Kuppler/Socket	
Gewicht Weight	ca./approx. 1.2 kg	ca./approx. 1.7 kg

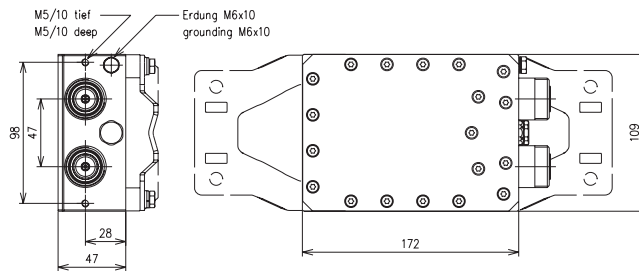
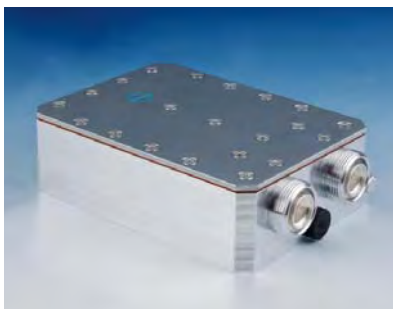
**Bestell-Nummer  
Part Number**

BN 61 63 96

BN B0 89 62

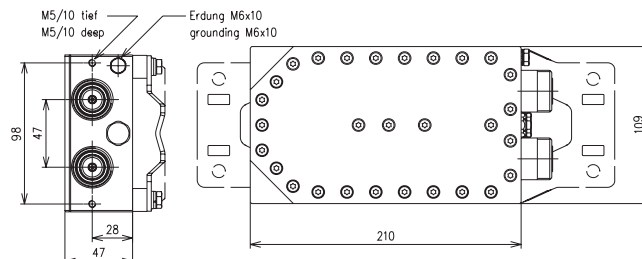
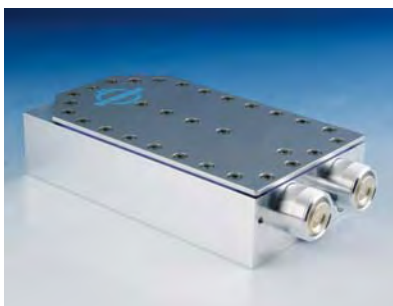
**Bestell-Nummer  
Part Number**

BN 61 63 98

BN B0 89 62

## COAXIAL FILTERS

### KOAXIALE BANDSPERR FILTER ■ COAXIAL BAND STOP FILTER

Bestell-Nummer Part Number	BN 61 63 14	BN 61 63 13
Sperrbereiche (GSM-R) Stop bands	876...880 MHz; 921 ... 925 MHz	
Sperrdämpfung Stop band attenuation	≥ 54 dB (876 ... 880 MHz) ≥ 50 dB (921 ... 925 MHz)	
Durchlassdämpfung Pass band attenuation	≤ 0.7 dB (890 ... 915 MHz) ≤ 0.4 dB (935 ... 960 MHz) ≤ 0.2 dB (1710 ... 1880 MHz) ≤ 0.2 dB (1920 ... 2170 MHz)	
VSWR	≤ 1.29	
Anschlussleistung Power rating	≤ 200 W	
Temperaturbereich Temperature range	-40 °C ... +85 °C	
Intermodulation (IM3) 2 x 20 W	≤ -150 dBc; typ. ≤ -160 dBc	
Schutzgrad Degree of protection	IP65	
Vibration und Schock Vibration and shock	geeignet für Bahnanwendungen / suitable for rail applications EN 50155 §10.2.11	
Anschlüsse (50 Ω) Connectors IEC 60169-4 IEC 60169-16	7-16 Kuppler/Socket	N Kuppler/Socket
Gewicht Weight	ca./approx. 6.5 kg	

COAXIAL FILTERS

KOAXIALE BANDSPERR FILTER ■ COAXIAL BAND STOP FILTER

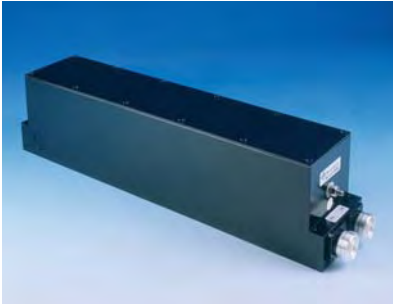

BN 61 63 14

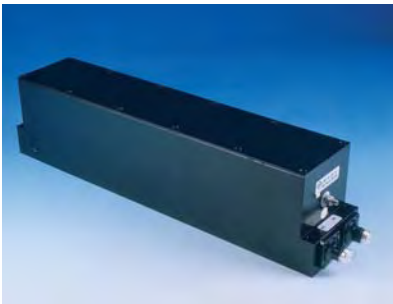
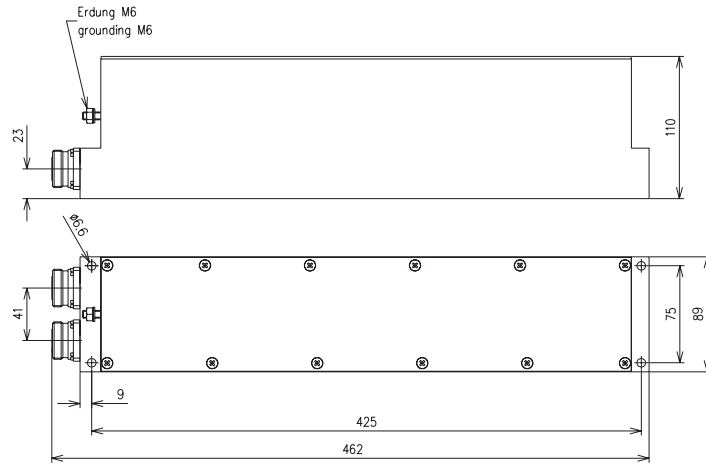

BN 61 63 13

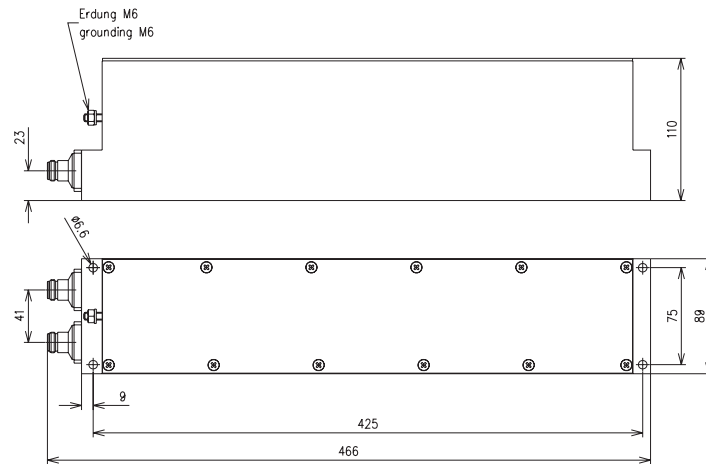



## DIPLEXER & TRIPLEXER



Frequenzweichen dienen zur Entkopplung von zwei oder mehr Kanälen unterschiedlicher Frequenz und erlauben damit die gemeinsame Nutzung eines Antennenspeisekabels bzw. einer Antenne durch mehrere Sender oder Empfänger.

SPINNER entwickelt und fertigt innovative Diplexer und Triplexer für alle heute genutzten Mobilfunk-Anwendungen. Mit der Verfügbarkeit von Weichen für Frequenzbänder im Bereich von 0 bis 2690 MHz ist unsere Diplexer- und Triplexerfamilie ideal zur Mehrfachnutzung von Antennenanlagen durch mehrere Mobilfunksysteme geeignet.

Neben Lösungen für CDMA800, CDMA850, GSM900, GSM1800, PCS1900 und UMTS2100 bietet SPINNER auch Diplexer für Analogfunk, TETRA, DVB-H, DMB, WLAN oder WiMAX an.

Alle Weichen arbeiten bidirektional und können somit zur Zusammenschaltung und Auftrennung der Sende- und Empfangssignale verwendet werden.

Niedrigste Einfügedämpfung, hervorragende Entkopplung und beste Intermodulationseigenschaften verhindern gegenseitige Störungen von benachbarten Systemen. AISG/3GPP kompatible DC-Verbindungen ermöglichen die Übertragung von Steuersignalen zur Antenne und die Stromversorgung von Antennenvorverstärkern.

Alle Diplexer und Triplexer sind für Innenraum- und Außenmontage geeignet.

Frequency combiners are used to de-couple two or more channels on different frequencies, thus allowing the common utilization of one antenna feed cable or one antenna by several transmitters or receivers.

SPINNER develops and manufactures innovative diplexers and triplexers for all mobile communication applications currently in use. Our combiners are available for frequency bands in the range from 0 to 2690 MHz, making our diplexer and triplexer families ideal for the common utilization of antenna equipment by several mobile communication systems.

Besides solutions for CDMA800, CDMA850, GSM900, GSM1800, PCS1900 and UMTS2100, SPINNER also offers diplexers for analogue radio, TETRA, DVB-H, DMB, WLAN and WiMAX.

All combiners work in bi-directional mode and can therefore be used to combine and split the transmitted and received signals.

Very low insertion loss, excellent de-coupling performance and superior intermodulation properties prevent mutual interference between neighboring systems. AISG/3GPP-compatible DC connections allow the transfer of control signals to the antenna as well as the power supply for antenna pre-amplifiers.

All diplexers and triplexers are suited for indoor and outdoor installation.

DIPLEXER

STRIPLINE DIPLEXER ■ GSM900 | 1800-UMTS

Bestell-Nummer Part Number	BN 57 36 40	BN 57 36 42	BN 57 36 41	BN 57 36 43
Ausführung Version	einfach single	zweifach double	einfach single	zweifach double
Frequenzbereich Frequency range	GSM900 Tor/port 1 GSM1800-UMTS Tor/port 2	806 ... 960 MHz 1710 ... 2170 MHz		
Durchgangsdämpfung Insertion loss	Tor/port 1 ↔ Tor/port 3 Tor/port 2 ↔ Tor/port 3	≤ 0.12 dB; typ. 0.10 dB ≤ 0.15 dB; typ. 0.13 dB		
Entkopplung Isolation	Tor/port 1 ↔ Tor/port 2	≥ 50 dB		
VSWR	≤ 1.2; typ. 1.1			
Anschlussleistung Power rating	Tor/port 1 Tor/port 2	≤ 570 W ≤ 380 W		
Intermodulation (IM3) 2 x 20 W	≤ -165 dBc; typ. -170 dBc			
Temperaturbereich Temperature range	-40 °C ... +85 °C			
Schutzgrad Degree of protection	IP68		IP68	
DC-Verbindung DC pass	alle Tore mit Tor 3 all ports with port 3		nur Tor 2 mit Tor 3 only port 2 with port 3	
DC current AISG Standard 2.0	≤ 5 A			
Anschlüsse (50 Ω) Connection IEC 60169-4	7-16 Kuppler/Socket			
Gewicht Weight	ca./approx. 0.8 kg	ca./approx. 1.8 kg	ca./approx. 0.8 kg	ca./approx. 1.8 kg
Mast- oder Wandhalterung Mast or wall mounting brackets	zu bestellen to be ordered BN B0 89 62	im Lieferumfang enthalten part of delivery	zu bestellen to be ordered BN B0 89 62	im Lieferumfang enthalten part of delivery

ZUBEHÖR ■ ACCESSORIES

Bestell-Nummer / Part Number

BN B0 89 62

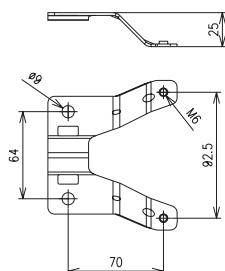

DIPLEXER

STRIPLINE DIPLEXER ■ GSM900 | 1800-UMTS

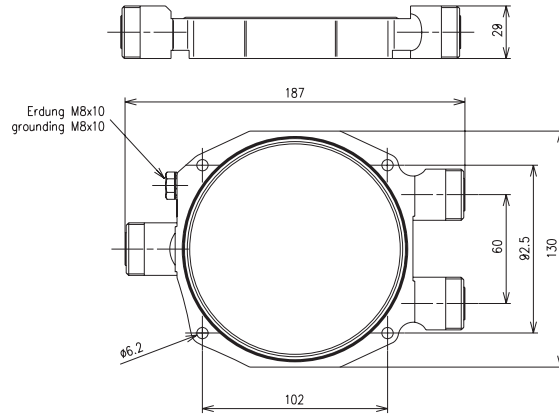

Bestell-Nummer  
Part Number

BN 57 36 40

BN 57 36 41

BN B0 89 62

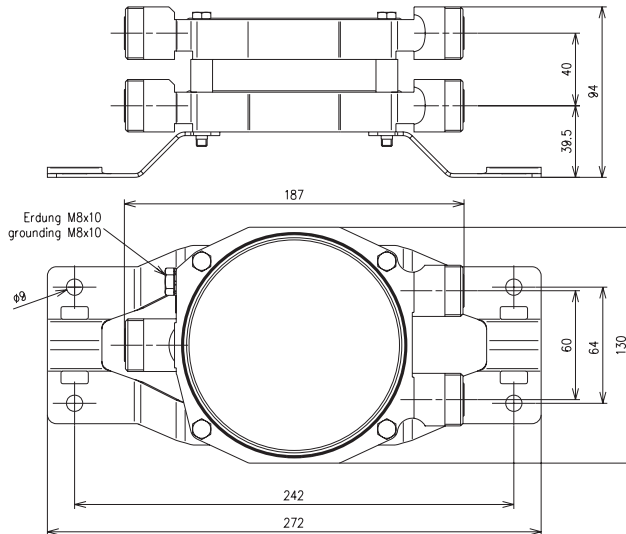

Bestell-Nummer  
Part Number

BN 57 36 42

BN 57 36 43

DIPLEXER

DIPLEXER ■ GSM1800 | UMTS

Bestell-Nummer Part Number	BN 57 36 27	BN 57 36 28	BN 57 36 26	BN 57 36 29
Ausführung Version	einfach single	zweifach double	einfach single	zweifach double
Frequenzbereich Frequency range	GSM1800 UMTS	1710 ... 1880 MHz 1920 ... 2170 MHz		Tor/port 1 Tor/port 2
Durchgangsdämpfung Insertion loss	Tor/port 1 ↔ Tor/port 3 Tor/port 2 ↔ Tor/port 3	≤ 0.35 dB; typ. 0.20 dB ≤ 0.45 dB; typ. 0.25 dB		
Entkopplung Isolation	Tor/port 1 ↔ Tor/port 2	≥ 50 dB		
VSWR	≤ 1.22; typ. 1.15			
Anschlussleistung Power rating	Tor/port 1 Tor/port 2	≤ 240 W ≤ 100 W		
Intermodulation (IM3) 2 x 20 W	≤ -160 dBc; typ. -165 dBc			
Temperaturbereich Temperature range	-40 °C ... +60 °C			
Schutzgrad Degree of protection	IP66			
DC-Verbindung DC pass	alle Tore mit Tor 3 all ports with port 3		nur Tor 2 mit Tor 3 only port 2 with port 3	
DC current AISG Standard 2.0	3 A			
Anschlüsse (50 Ω) Connection IEC 60169-4	7-16 Kuppler/Socket			
Gewicht Weight	ca./approx. 3.6 kg	ca./approx. 7.5 kg	ca./approx. 3.6 kg	ca./approx. 7.5 kg
Mast- oder Wandhalterung Mast or wall mounting brackets	zu bestellen/to be ordered BN B0 89 53			

ZUBEHÖR ■ ACCESSORIES

<b>Bestell-Nummer / Part Number</b>
BN B0 89 53

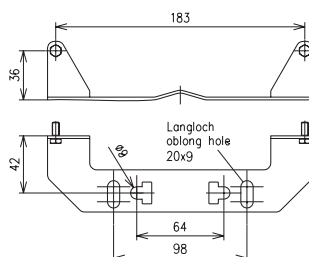



## DIPLEXER

DIPLEXER ■ GSM1800 | UMTS

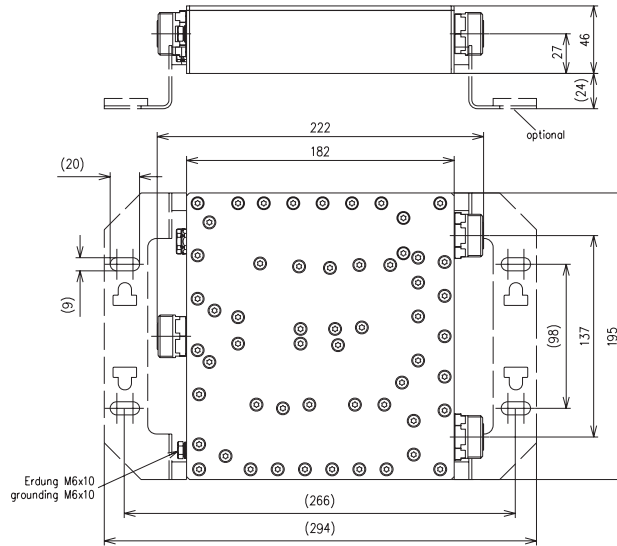
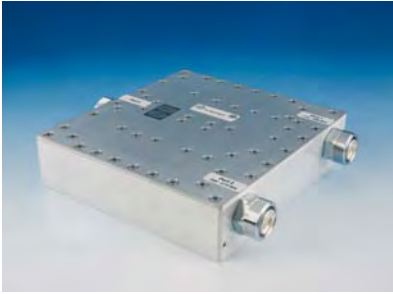

**Bestell-Nummer**  
**Part Number**

BN 57 36 27

BN 57 36 26

BN B0 89 53

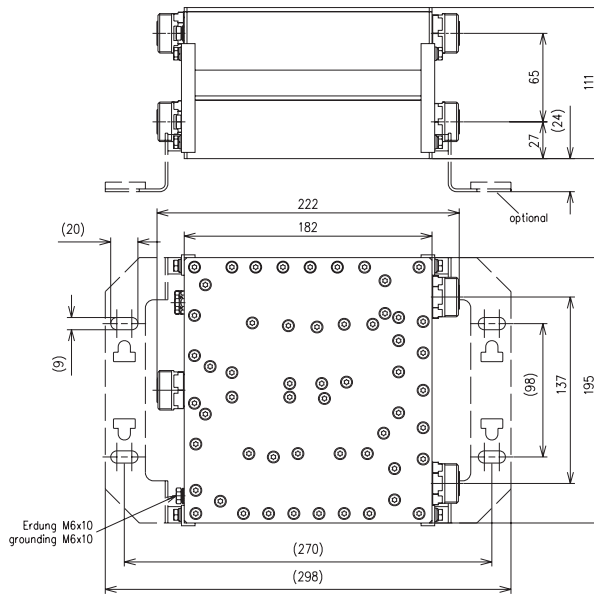
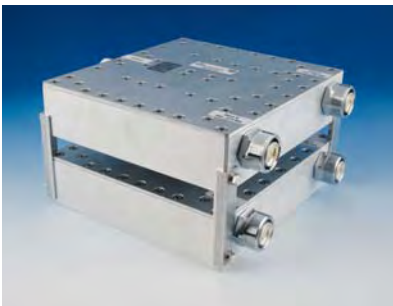

**Bestell-Nummer**  
**Part Number**

BN 57 36 28

BN 57 36 29

BN B0 89 53

DIPLEXER

DIPLEXER ■ MULTIBAND

Bestell-Nummer Part Number		BN 57 31 89	BN 57 31 91
Ausführung Version		einfach single	zweifach double
Frequenzbereich Frequency range	GSM900/GSM1800/UMTS/WLAN Tor/port 1 Range 1 Range 2 FM Broadcasting/PMR/TETRA Tor/port 2 Range 3 Range 4 Range 5	800 ... 960 MHz 1710 ... 2500 MHz 68 ... 200 MHz 200 ... 380 MHz 380 ... 470 MHz	
Durchgangsdämpfung Insertion loss	Tor/port 1 ↔ Tor/port 3 Range 1,2 Tor/port 2 ↔ Tor/port 3 Range 3,4,5	≤ 0.2 dB; typ. 0.10 dB ≤ 0.2 dB; typ. 0.15 dB	
Entkopplung Isolation	Tor/port 1 ↔ Tor/port 2 Range 1,2 Tor/port 2 ↔ Tor/port 3 Range 3,4,5	≥ 50 dB ≥ 30 dB	
VSWR	Tor/port 1 Range 1,2 Tor/port 2 Range 3,5 Tor/port 2 Range 4	≤ 1.20; typ. 1.15 ≤ 1.20; typ. 1.15 ≤ 1.35; typ. 1.20	
Anschlussleistung Power rating	Tor/port 1 Tor/port 2	≤ 500 W ≤ 300 W	
Intermodulation (IM3) 2 x 20 W		≤ -155 dBc; typ. -160 dBc	
Temperaturbereich Temperature range		-40 °C ... +65 °C	
Schutzgrad Degree of protection		IP65	
DC-Verbindung DC pass		nur Tor 2 mit Tor 3 only port 2 with port 3	
DC current AISG Standard 2.0		5 A	
Anschlüsse (50 Ω) Connection IEC 60169-4		7-16 Kuppler/Socket	
Gewicht Weight		ca./approx. 1.5 kg	ca./approx. 3.6 kg
Mast- oder Wandhalterung Mast or wall mounting brackets		im Lieferumfang enthalten part of delivery	

DIPLEXER

DIPLEXER ■ MULTIBAND

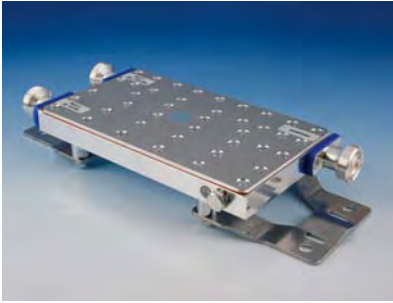

BN 57 31 89

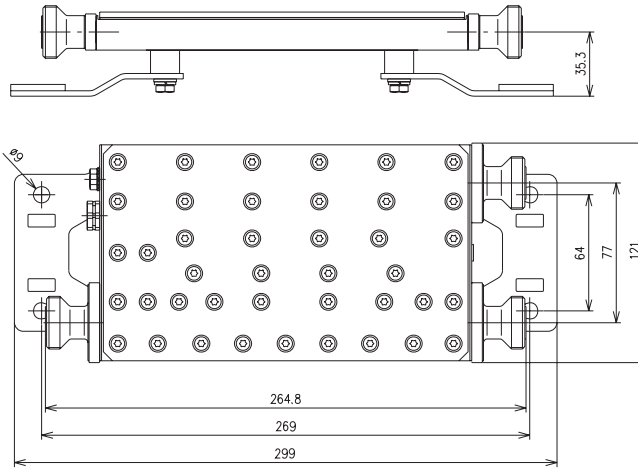

BN 57 31 91

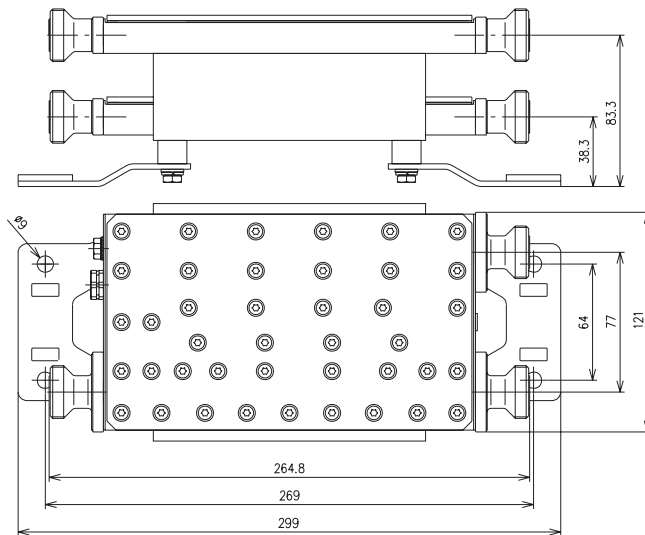

DIPLEXER

DIPLEXER ■ GSM-RAIL

Bestell-Nummer Part Number	BN 57 29 24
Frequenzbereich analog radio Tor/port 1 Frequency range GSM-R/GSM900 Tor/port 2	440 ... 475 MHz 870 ... 960 MHz
Durchgangsdämpfung Insertion loss	≤ 0.2 dB; typ. 0.15 dB
Entkopplung Isolation	≥ 60 dB
VSWR	≤ 1.15; typ. 1.07
Anschlussleistung pro Eingang Power rating per input	≤ 50 W
Intermodulation (IM3) 2 x 20 W	≤ -150 dBc; typ. -160 dBc
Temperaturbereich Temperature range	-40 °C ... +70 °C
Schutzgrad Degree of protection	IP65
DC-Verbindung DC pass	alle Tore mit Tor 3 all ports with port 3
DC current AISG Standard 2.0	3 A
Anschlüsse (50 Ω) Connection IEC 60169-16	N Kuppler/Socket
Gewicht Weight	ca./approx. 1.25 kg
Besonderheiten Special features	zugelassen für Bahnanwendungen / approved for rail applications Innenleiter vergoldet / inner conductor gold-plated



BN 57 29 24

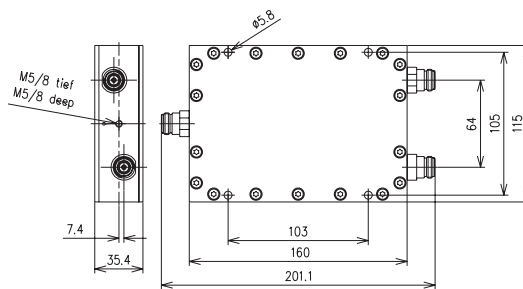

## DIPLEXER

### DIPLEXER ■ DVB-H

<b>Bestell-Nummer</b> <b>Part Number</b>	<b>BN 57 35 02</b>		
Frequenzbereich Frequency range	GSM900 GSM1800/UMTS TETRA/DVB-H	Tor/port 1 Range 1 Tor/port 1 Range 2 Tor/port 2 Range 3	860 ... 960 MHz 1710 ... 2170 MHz 380 ... 710 MHz
Durchgangsdämpfung Insertion loss	Tor/port 1 ↔ Tor/port 3 Tor/port 2 ↔ Tor/port 3		≤ 0.4 dB; typ. 0.2 dB ≤ 0.5 dB; typ. 0.2 dB
Entkopplung Isolation	≥ 50 dB		
VSWR	≤ 1.3; typ. 1.2		
Anschlussleistung Power rating	Tor/port 1 Tor/port 2		≤ 300 W ≤ 200 W
Intermodulation (IM3) 2 x 20 W	≤ -155 dBc; typ. -160 dBc		
Temperaturbereich Temperature range	-40 °C ... +55 °C		
Schutzgrad Degree of protection	IP65		
DC-Verbindung DC pass	alle Tore mit Tor 3 all ports with port 3		
DC current AISG Standard 2.0	5 A		
Anschlüsse (50 Ω) Connection IEC 60169-4	7-16 Kuppler/Socket		
Gewicht Weight	ca./approx. 3.5 kg		

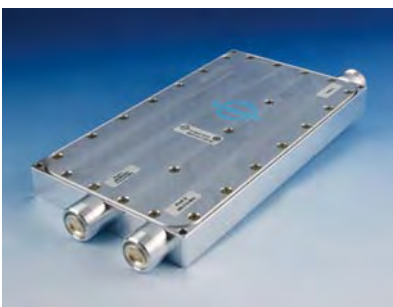

BN 57 35 02

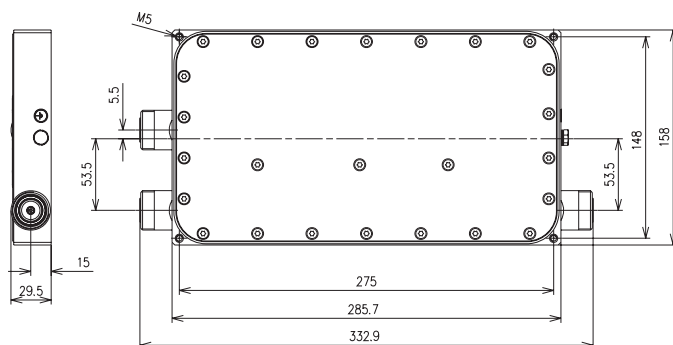

DIPLEXER

DIPLEXER ■ TETRA | DVB-H

<b>Bestell-Nummer</b> <b>Part Number</b>	<b>BN 57 36 59</b>		
Frequenzbereich TETRA Tor/port 1 Range 1	380 ... 400 MHz		
Frequency range DVB-H Tor/port 2 Range 2	470 ... 710 MHz		
Durchgangsdämpfung Insertion loss	≤ 0.4 dB; typ. 0.25 dB		
Entkopplung Isolation	≥ 50 dB		
VSWR	≤ 1.2; typ. 1.1		
Anschlussleistung Power rating	≤ 200 W		
Intermodulation (IM3) 2 x 20 W	≤ -155 dBc; typ. -160 dBc		
Temperaturbereich Temperature range	-40 °C ... +55 °C		
Schutzgrad Degree of protection	IP65		
DC-Verbindung DC pass	alle Tore mit Tor 3 all ports with port 3		
DC current AISG Standard 2.0	3 A		
Anschlüsse (50 Ω) Connection IEC 60169-4	7-16 Kuppler/Socket		
Gewicht Weight	ca./approx. 4.5 kg		



BN 57 36 59

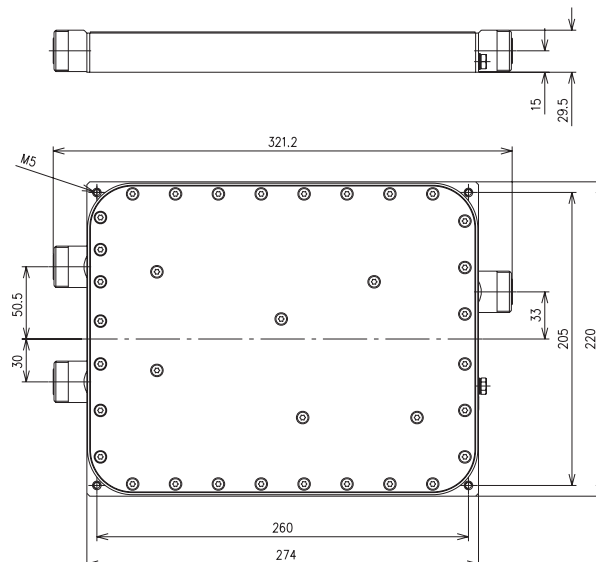

### DIPLEXER ■ WiMAX BROADBAND

<b>Bestell-Nummer</b> <b>Part Number</b>	<b>BN 57 36 16</b>		
Frequenzbereich broadband Frequency range LTE/WiMax	Tor/port 1 Tor/port 2	Range 1 Range 2	0 ... 2170 MHz 2500 ... 2700 MHz
Durchgangsdämpfung Insertion loss	Tor/port 1 ↔ Tor/port 3 Tor/port 2 ↔ Tor/port 3		≤ 0.2 dB; typ. 0.1 dB ≤ 0.4 dB; typ. 0.2 dB
Entkopplung Isolation	Tor/port 1 ↔ Tor/port 2 Tor/port 2 ↔ Tor/port 1		≥ 60 dB ≥ 50 dB
VSWR	Tor/port 1 Tor/port 2		≤ 1.20; typ. 1.10 ≤ 1.25; typ. 1.15
Anschlussleistung Power rating	Tor/port 1 Tor/port 2		≤ 500 W ≤ 300 W
Intermodulation (IM3) 2 x 20 W	≤ -155 dBc; typ. -160 dBc		
Temperaturbereich Temperature range	-40 °C ... +55 °C		
Schutzgrad Degree of protection	IP65		
DC-Verbindung DC pass	Tor 1 mit Tor 3 port 1 with port 3		
DC current AISG Standard 2.0	5 A		
Anschlüsse (50 Ω) IEC 60169-4 Connection (50 Ω) IEC 60169-16	Tor/port 1 Tor/port 2		7-16 Kuppler/Socket N Kuppler/Socket
Gewicht Weight	ca./approx. 1.5 kg		
Mast- oder Wandhalterung Mast or wall mounting brackets	zu bestellen / to be ordered BN B0 77 14		

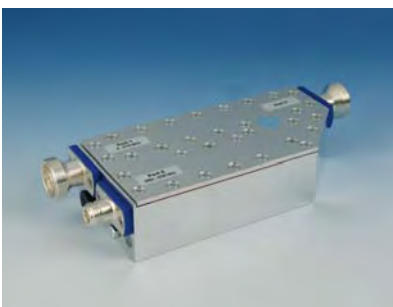

BN 57 36 16

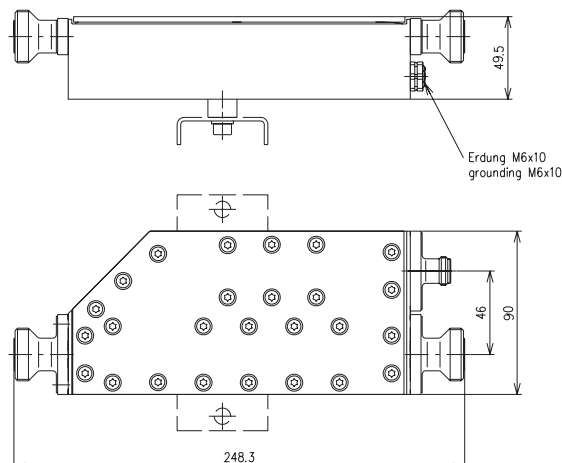

TRIPLEXER

TRIPLEXER ■ GSM900 | GSM1800 | UMTS

Bestell-Nummer Part Number	BN 57 36 30	BN 57 36 32	BN 57 36 31	BN 57 36 33
Ausführung Version	einfach single	zweifach double	einfach single	zweifach double
Frequenzbereich Frequency range	GSM900 Tor/port 1 GSM1800 Tor/port 2 UMTS Tor/port 3	806 ... 960 MHz 1710 ... 1880 MHz 1920 ... 2170 MHz		
Durchgangsdämpfung Insertion loss	Tor/port 1 ↔ Tor/port 4 Tor/port 2 ↔ Tor/port 4 Tor/port 3 ↔ Tor/port 4	≤ 0.20 dB; typ. 0.15 dB ≤ 0.35 dB; typ. 0.20 dB ≤ 0.45 dB; typ. 0.25 dB		
Entkopplung Isolation	Tor/port 1 ↔ Tor/port 2,3 Tor/port 2 ↔ Tor/port 1,3 Tor/port 3 ↔ Tor/port 1,2	≥ 50 dB		
VSWR	≤ 1.22; typ. 1.15			
Anschlussleistung Power rating	Tor/port 1 Tor/port 2 Tor/port 3	≤ 240 W ≤ 240 W ≤ 100 W		
Intermodulation (IM3) 2 x 20 W	≤ -160 dBc; typ. -165 dBc			
Temperaturbereich Temperature range	-40 °C ... +60 °C			
Schutzgrad Degree of protection	IP66			
DC-Verbindung DC pass	alle Tore mit Tor 4 all ports with port 4		nur Tor 3 mit Tor 4 only port 3 with port 4	
DC current AISG Standard 2.0	3 A			
Anschlüsse (50 Ω) Connection IEC 60169-4	7-16 Kuppler/Socket			
Gewicht Weight	ca./approx. 3.6 kg	ca./approx. 7.5 kg	ca./approx. 3.6 kg	ca./approx. 7.5 kg
Mast- oder Wandhalterung Mast or wall mounting brackets	zu bestellen/to be ordered BN B0 89 53			

ZUBEHÖR ■ ACCESSORIES

<b>Bestell-Nummer / Part Number</b>
BN B0 89 53

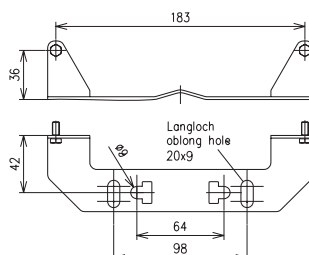



## TRIPLEXER

TRIPLEXER ■ GSM900 | GSM1800 | UMTS

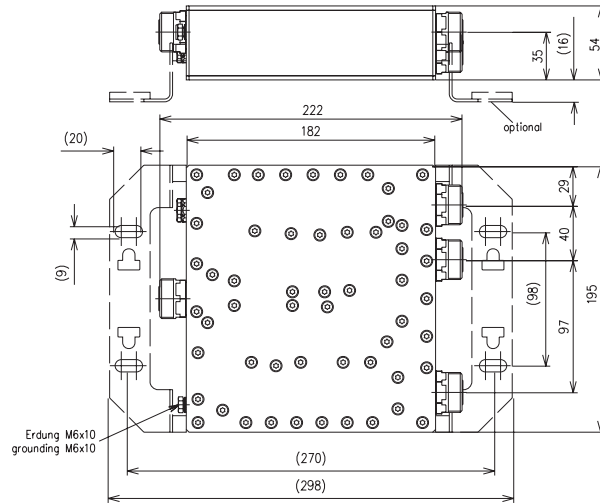
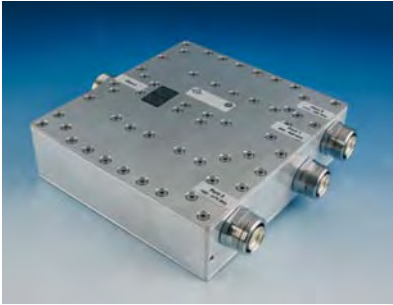

**Bestell-Nummer**  
**Part Number**

BN 57 36 30

BN 57 36 31

BN B0 89 53

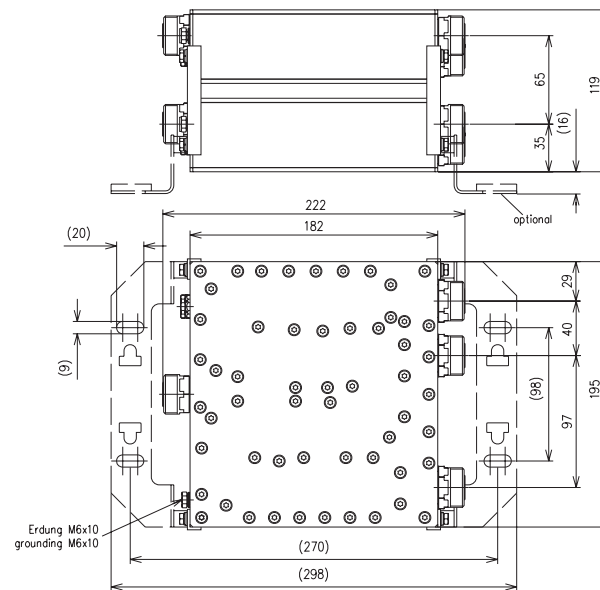
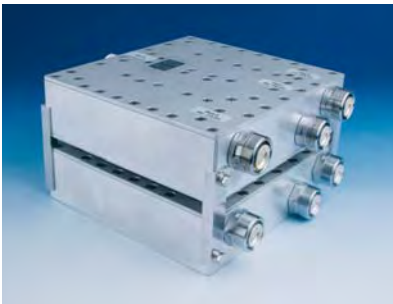

**Bestell-Nummer**  
**Part Number**

BN 57 36 32

BN 57 36 33

BN B0 89 53

MULTIPLEXER

Multiplexer trennen Sende- und Empfangssignale von Mobilfunk-Basisstationen und führen die korrespondierenden Signale über Bandpassfilter und Sternpunkte zusammen.

Multiplexers separate the transmitted and received signals of mobile communication ground stations and combine the corresponding signals via band pass filters and star points.

SPINNER Filter-Multiplexer zeichnen sich durch eine geringe Einfügedämpfung, eine hohe Isolation zwischen den Frequenzblöcken sowie durch sehr niedrige Intermodulationswerte aus.

SPINNER filter multiplexers stand out for low insertion loss, high de-coupling between frequency blocks and very low intermodulation values.

Wir bieten eine Vielzahl Multiplexer für GSM900, GSM1800 und UMTS an, die auf Bandbreiten von 4 bis 20 MHz abgeglichen werden können.

We offer a broad variety of multiplexers for GSM900, GSM1800 and UMTS that can be tuned to bandwidths between 4 and 20 MHz.

Aufbau eines 2-fach UMTS Multiplexer | Design of a 2-way UMTS Multiplexer

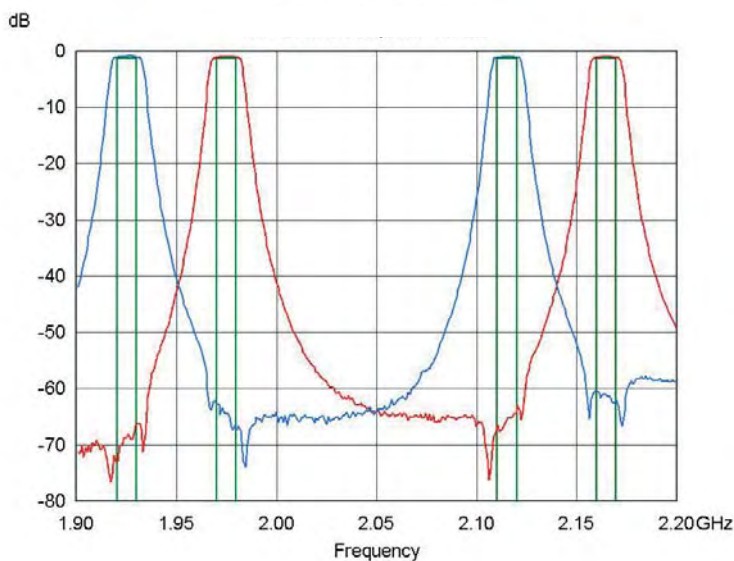
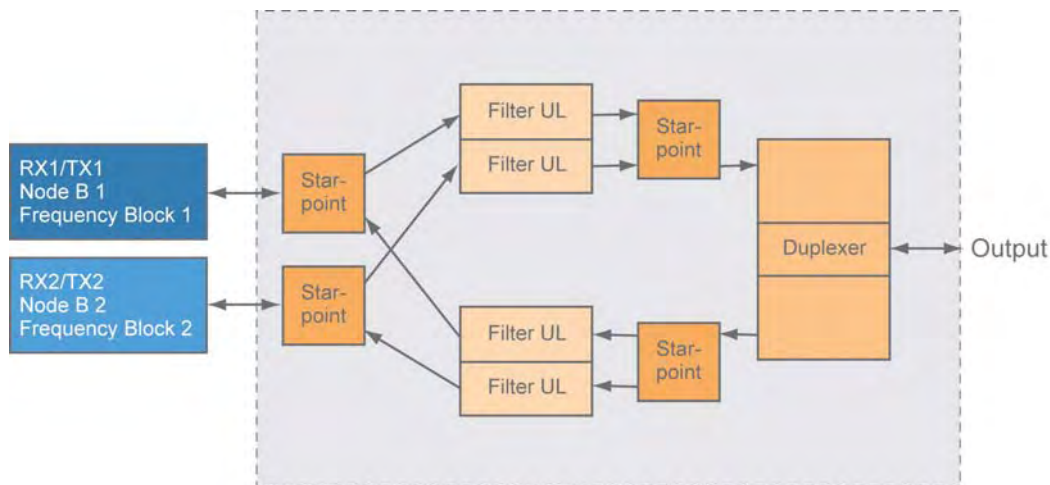

Typischer Dämpfungsverlauf zweier UMTS-Frequenzbänder RX1/TX1 und RX2/TX2

Typical attenuation graph of two UMTS frequency bands, RX1/TX1 and RX2/TX2



## MULTIPLEXER

Die nachfolgend dargestellten Typen stellen nur eine kleine Auswahl der verfügbaren Varianten dar.

The following types represent just a small choice of offered alternatives.

<b>Frequenzband Frequency band</b>	<b>Eingänge Input</b>	<b>Ausgänge Output</b>	<b>Bestell-Nummer Part Number</b>
UMTS	2	1	BN 57 36 50
UMTS	2x 2	2	BN 57 36 51
UMTS	2	1	BN 57 36 52
UMTS	2x 2	2	BN 57 36 53
UMTS	2	1	BN 57 36 13
UMTS	2	1	BN 57 36 84
GSM1800	2	1	BN 57 36 63
GSM1800	2x 2	2	BN 57 36 64
GSM900	2	1	BN 57 36 62
TETRA	2	1	BN 57 36 09

MULTIPLEXER

MULTIPLEXER ■ UMTS

Bestell-Nummer Part Number		BN 57 36 50	BN 57 36 51
Ausführung Version		einfach single	zweifach double
Frequenzbereich Frequency range	Tor/port 1 Tor/port 2	1920.3 ... 1930.2 MHz / 2110.3 ... 2120.2 MHz 1969.8 ... 1979.7 MHz / 2159.8 ... 2169.7 MHz	
Durchgangsdämpfung Insertion loss		≤ 1.4 dB	
Entkopplung Isolation		≥ 55 dB	
VSWR		≤ 1.25	
Anschlussleistung pro Eingang Power rating per input		≤ 65 W	
Intermodulation (IM3) 2 x 20 W		≤ -150 dBc; typ. -160 dBc	
Temperaturbereich Temperature range		-25 °C ... +85 °C	
Schutzgrad Degree of protection		IP65	
DC-Verbindung (umschaltbar) DC by pass (switchable)		Tor 1 oder Tor 2 mit Tor 3 port 1 or port 2 with port 3	
Anschlüsse (50 Ω) Connection IEC 60169-4		7-16 Kuppler/Socket	
Gewicht Weight		ca./approx. 10 kg	ca./approx. 20 kg
Mast- oder Wandhalterung Mast or wall mounting brackets		im Lieferumfang enthalten part of delivery	

MULTIPLEXER

MULTIPLEXER ■ UMTS



BN 57 36 50

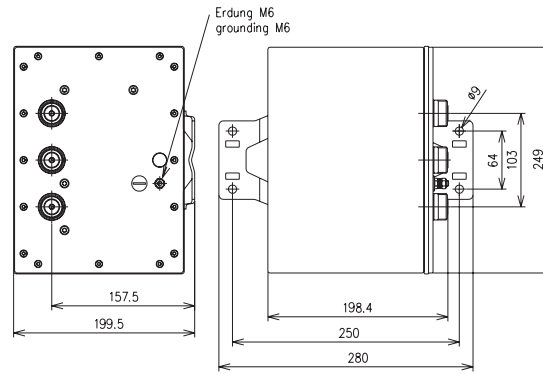

BN 57 36 51

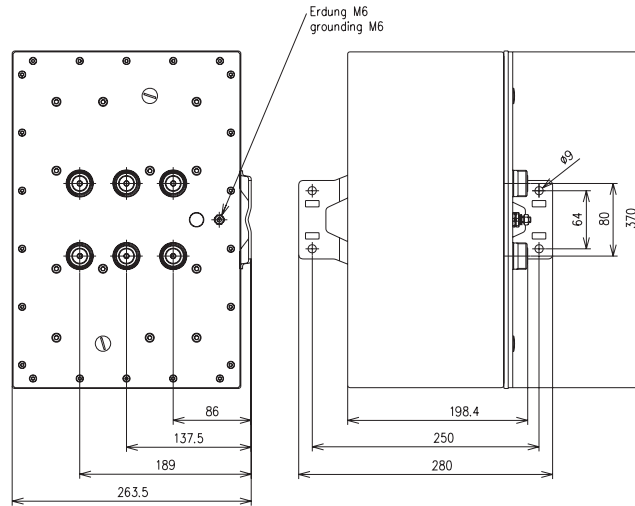

MULTIPLEXER

MULTIPLEXER ■ UMTS

Bestell-Nummer Part Number		BN 57 36 52	BN 57 36 53
Ausführung Version		einfach single	zweifach double
Frequenzbereich Frequency range	Tor/port 1 Tor/port 2	1940.1 ... 1950.0 MHz / 2130.1 ... 2140.0 MHz 1959.9 ... 1969.8 MHz / 2149.9 ... 2159.8 MHz	
Durchgangsdämpfung Insertion loss		≤ 1.4 dB	
Entkopplung Isolation		≥ 30 dB	
VSWR		≤ 1.25	
Anschlussleistung pro Eingang Power rating per input		≤ 65 W	
Intermodulation (IM3) 2 x 20 W		≤ -150 dBc; typ. -160 dBc	
Temperaturbereich Temperature range		-25 °C ... +85 °C	
Schutzgrad Degree of protection		IP65	
DC-Verbindung (umschaltbar) DC by pass (switchable)		Tor 1 oder Tor 2 mit Tor 3 port 1 or port 2 with port 3	
Anschlüsse (50 Ω) Connection IEC 60169-4		7-16 Kuppler/Socket	
Gewicht Weight		ca./approx. 10 kg	ca./approx. 20 kg
Mast- oder Wandhalterung Mast or wall mounting brackets		im Lieferumfang enthalten part of delivery	

MULTIPLEXER

MULTIPLEXER ■ UMTS



BN 57 36 52

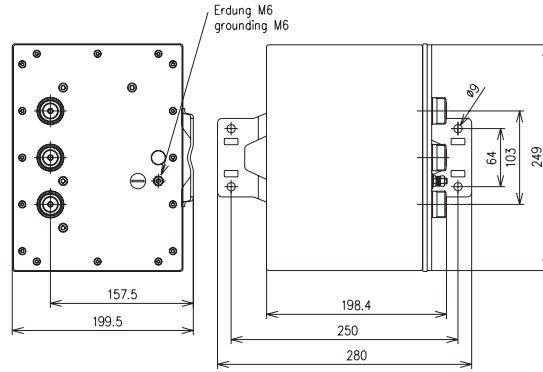

BN 57 36 53

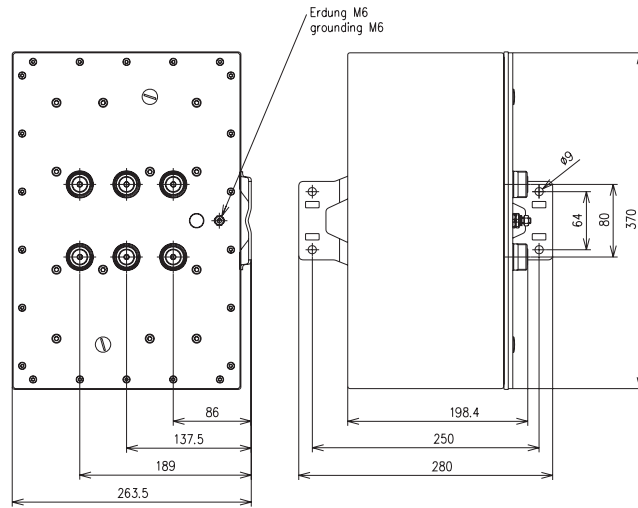

MULTIPLEXER

MULTIPLEXER ■ UMTS

Bestell-Nummer Part Number		BN 57 36 13	BN 57 36 84
Frequenzbereich Frequency range	Tor/port 1 Tor/port 2	1950 ... 1955 MHz / 2140 ... 2145 MHz 1960 ... 1965 MHz / 2150 ... 2155 MHz	1950.0 ... 1959.9 MHz / 2140.0 ... 2149.9 MHz 1969.8 ... 1979.7 MHz / 2159.8 ... 2169.7 MHz
Durchgangsdämpfung Insertion loss		≤ 1.5 dB	
Entkopplung Isolation		≥ 35 dB	
VSWR		≤ 1.25	
Anschlussleistung pro Eingang Power rating per input		≤ 65 W	
Intermodulation (IM3) 2 x 20 W		≤ -150 dBc; typ. -160 dBc	
Temperaturbereich Temperature range		-25 °C ... +85 °C	
Schutzgrad Degree of protection		IP65	
DC-Verbindung (umschaltbar) DC by pass (switchable)		Tor 1 oder Tor 2 mit Tor 3 port 1 or port 2 with port 3	
Anschlüsse (50 Ω) Connection IEC 60169-4		7-16 Kuppler/Socket	
Gewicht Weight		ca./approx. 10 kg	
Mast- oder Wandhalterung Mast or wall mounting brackets		im Lieferumfang enthalten part of delivery	





# MNCS<sup>®</sup> – MOBILE NETWORK COMBINING SYSTEM

## MULTIPLEXER

### MULTIPLEXER ■ UMTS

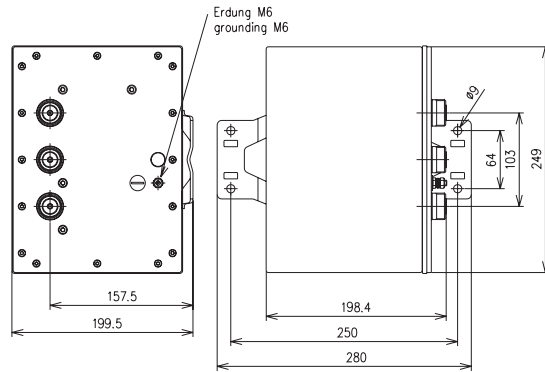

**Bestell-Nummer**  
**Part Number**

BN 57 36 13

BN 57 36 84



MULTIPLEXER

MULTIPLEXER ■ GSM1800

Bestell-Nummer Part Number		BN 57 36 63	BN 57 36 64
Frequenzbereich Frequency range	Tor/port 1	1730.1 ... 1752.5 MHz / 1825.1 ... 1847.5 MHz 1758.1 ... 1780.5 MHz / 1853.1 ... 1875.5 MHz	1725.1 ... 1730.1 MHz / 1820.1 ... 1825.1 MHz
	Tor/port 2		1752.7 ... 1758.1 MHz / 1847.7 ... 1853.1 MHz
	Tor/port 4		1730.1 ... 1752.5 MHz / 1825.1 ... 1847.5 MHz
	Tor/port 5		1758.1 ... 1780.5 MHz / 1853.1 ... 1875.5 MHz
Durchgangsdämpfung Insertion loss		≤ 1.8 dB	
Entkopplung Isolation		≥ 35 dB	
VSWR		≤ 1.25	
Anschlussleistung pro Eingang Power rating per input		≤ 50 W	
Intermodulation (IM3) 2 x 20 W		≤ -150 dBc; typ. -160 dBc	
Temperaturbereich Temperature range		-25 °C ... +85 °C	
Schutzgrad Degree of protection		IP65	
DC-Verbindung (umschaltbar) DC by pass (switchable)		Tor 1 oder Tor 2 mit Tor 3/port 1 or port 2 with port 3 Tor 4 oder Tor 5 mit Tor 6/port 4 or port 5 with port 6	
Anschlüsse (50 Ω) Connection IEC 60169-4		7-16 Kuppler/Socket	
Gewicht Weight		ca./approx. 10 kg	ca./approx. 20 kg
Mast- oder Wandhalterung Mast or wall mounting brackets		im Lieferumfang enthalten part of delivery	

MULTIPLEXER

MULTIPLEXER ■ GSM1800



BN 57 36 63

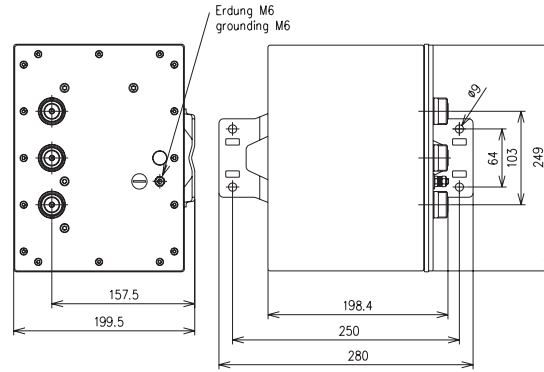

BN 57 36 64

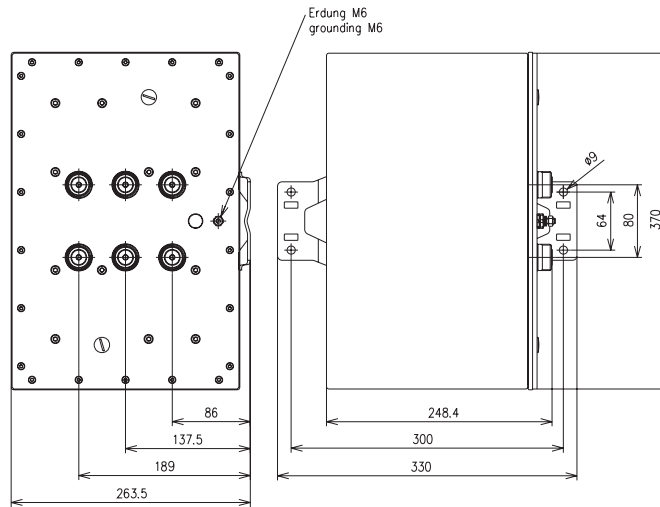

MULTIPLEXER

MULTIPLEXER ■ GSM900

Bestell-Nummer Part Number	BN 57 36 62	
Frequenzbereich Frequency range	Tor/port 1 Tor/port 2	890 ... 897.5 MHz / 935 ... 942.5 MHz 907.5 ... 915 MHz / 952.5 ... 960 MHz
Durchgangsdämpfung Insertion loss	≤ 1.4 dB	
Entkopplung Isolation	≥ 30 dB	
VSWR	≤ 1.2	
Anschlussleistung pro Eingang Power rating per input	≤ 50 W	
Intermodulation (IM3) 2 x 20 W	≤ -150 dBc; typ. -160 dBc	
Temperaturbereich Temperature range	-20 °C ... +70 °C	
Schutzgrad Degree of protection	IP65	
DC-Verbindung (umschaltbar) DC by pass (switchable)	Tor 1 oder Tor 2 mit Tor 3 port 1 oder port 2 mit port 3	
Anschlüsse (50 Ω) Connection IEC 60169-4	7-16 Kuppler/Socket	
Gewicht Weight	ca./approx. 17 kg	
Mast- oder Wandhalterung Mast or wall mounting brackets	im Lieferumfang enthalten part of delivery	

MULTIPLEXER

MULTIPLEXER ■ GSM900



BN 57 36 62

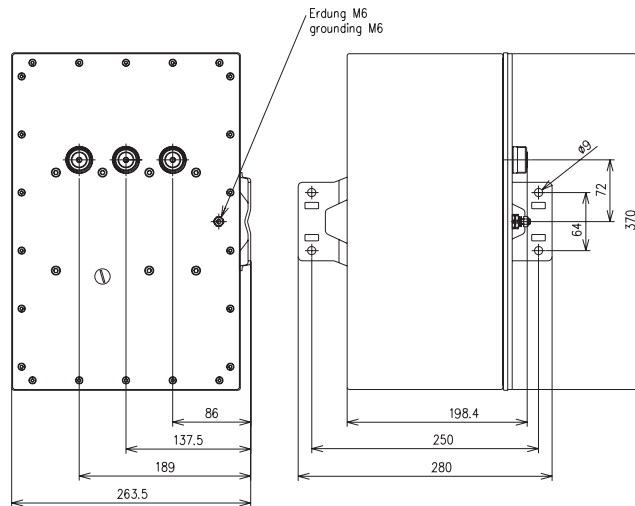

DUPLEXER

DUPLEXER ■ TETRA RX/TX

<b>Bestell-Nummer</b> <b>Part Number</b>	<b>BN 57 36 09</b>	
Frequenzbereich Frequency range	Tor/port 1 Tor/port 2	380 ... 385 MHz 390 ... 395 MHz
Durchgangsdämpfung Insertion loss	≤ 1.1 dB	
Entkopplung Isolation	≥ 70 dB	
VSWR	≤ 1.25	
Anschlussleistung pro Eingang Power rating per input	≤ 200 W	
Temperaturbereich Temperature range	-5 °C ... +55 °C	
Schutzgrad Degree of protection	IP54	
Anschlüsse (50 Ω) Connection IEC 60169-4	7-16 Kuppler/Socket	
Gewicht Weight	ca./approx. 9 kg	
Mast- oder Wandhalterung Mast or wall mounting brackets	zu bestellen/to be ordered BN B0 89 53	

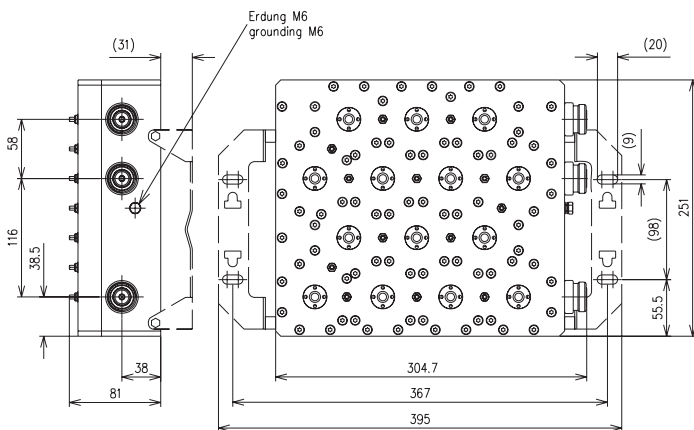

ZUBEHÖR ■ ACCESSORIES

<b>Bestell-Nummer / Part Number</b>
BN B0 89 53

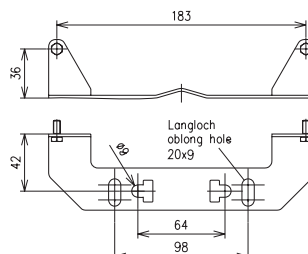

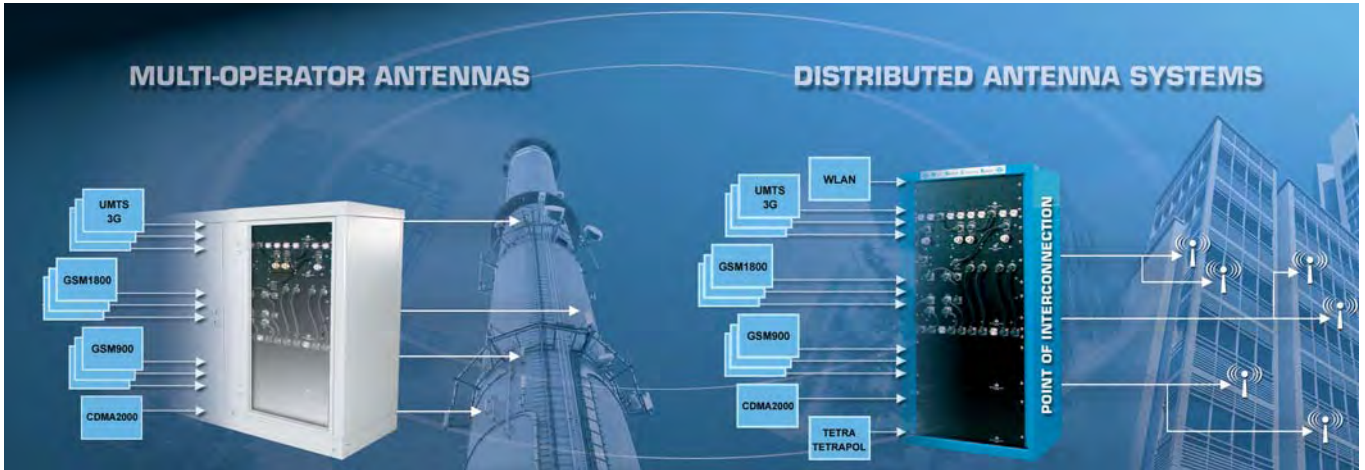

Mit unserem MNCS®-System bieten wir eine zukunfts-sichere Lösung für die Mehrfachnutzung von Antennenanlagen im freien Funkfeld sowie bei der Inhouse- und Tunnelversorgung.

Bei einer Bandbreite von 330 bis 2700 MHz umfasst das System alle aktuell genutzten Frequenzbänder. Die eingesetzten Filter-Baugruppen garantieren eine hohe Entkopplung der angeschlossenen Mobilfunk-signale. Gegenseitige Beeinflussung der verbundenen Sende-Empfangsanlagen werden dadurch verhindert. Die Verwendung ausschließlich passiver Komponenten ermöglicht niedrigste Intermodulationswerte. Durch den modularen Aufbau des Systems sind jederzeit Änderungen und Erweiterungen möglich. Weitere Vorteile gegenüber herkömmlichen Lösungen sind:

- kompaktes Design in 19" Bauweise
- kurze Abschaltzeiten bei Installationen
- vormontierte und geprüfte Technik
- kostengünstig

Realisierte Inhouse-Projekte wie z. B. der UNO-Campus in Bonn, die Messe Wien und der Keppler Bay Tower in Singapur zeigen die hohe Zuverlässigkeit und Qualität unserer Systeme.

Aus unseren über 200 Modulvarianten stellen wir Ihnen nachfolgend 11 Grundtypen vor. Zudem bieten wir einen qualifizierten Rundum-Service an – von der technischen Beratung über die Projektierung bis zur Vorort-Installation.

Our MNCS® system offers a future-oriented solution for the multiple utilization of antenna equipment outdoors as well as in-house and tunnel radio systems.

The system bandwidth between 330 and 2700 MHz covers all frequency bands that are currently in use. We use filter assemblies which guarantee good decoupling of the connected mobile communication signals.

This prevents any mutual interference of transceiver stations. Since we use exclusively passive components, the intermodulation values are extremely low. The modular system design allows you to make changes and extensions whenever necessary. Further advantages over traditional systems include:

- compact design with 19" technology
- short shutdown time for installation
- pre-assembled and tested equipment
- cost-efficiency

Successful in-house projects, such as the UN Campus in Bonn, the Vienna exhibition grounds and Keppler Bay Tower in Singapore demonstrate the reliability and quality of our systems.

We make more than 200 module variants, with 11 basic types described below. In addition we offer our qualified complete service – from technical consulting and project design to on-site installation.

MODULES

MULTIPLEXER MODULE ■ UMTS

Bestell-Nummer Part Number		BN 57 34 58	BN 57 34 51
Frequenzbereich Frequency range	Tor/port 1	1969.8 ... 1979.7 MHz / 2159.8 ... 2169.7 MHz	1969.8 ... 1979.7 MHz / 2159.8 ... 2169.7 MHz
	Tor/port 2	1920.3 ... 1930.2 MHz / 2110.3 ... 2120.2 MHz	1920.3 ... 1930.2 MHz / 2110.3 ... 2120.2 MHz
	Tor/port 3	–	1959.9 ... 1969.8 MHz / 2149.9 ... 2159.8 MHz
	Tor/port 4	–	1940.1 ... 1950.0 MHz / 2130.1 ... 2140.0 MHz
Durchgangsdämpfung Insertion loss		≤ 1.4 dB	
Entkopplung Isolation	Tor/port 1 ↔ Tor/port 2	≥ 50 dB	≥ 50 dB
	Tor/port 3 ↔ Tor/port 4	–	≥ 30 dB
VSWR		≤ 1.2	
Anschlussleistung pro Eingang Power rating per input		≤ 50 W	
Intermodulation (IM3) 2 x 20 W		≤ -150 dBc; typ. -160 dBc	
Temperaturbereich Temperature range		-5 °C ... +55 °C	
Schutzgrad Degree of protection		IP20	
DC-Verbindung DC by pass		nur extern über zusätzliche DC-Einspeisung only external with BIAS-T	
Anschlüsse (50 Ω) Connection IEC 60169-4		7-16 Kuppler/Socket	
Abmessungen Höheneinheiten Dimensions Rack units		5 (222 mm)	



MULTIPLEXER MODULE ■ UMTS

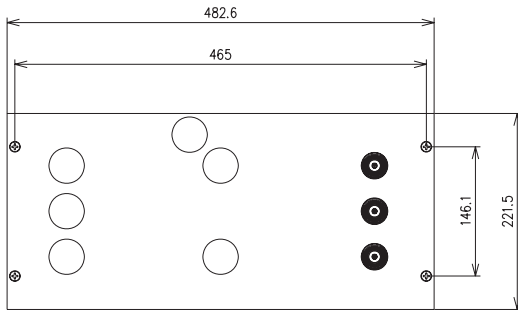

Bestell-Nummer  
Part Number

BN 57 34 58

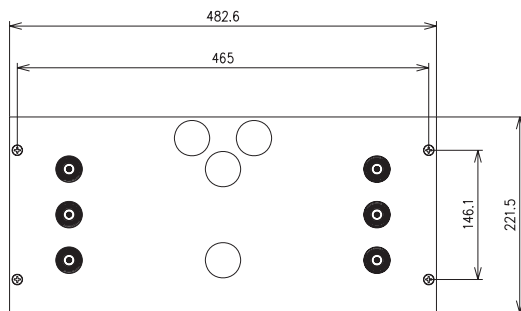
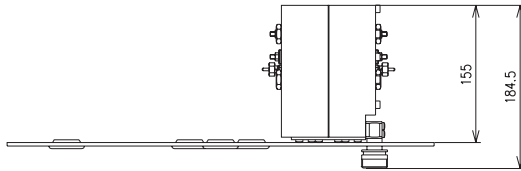

Bestell-Nummer  
Part Number

BN 57 34 51

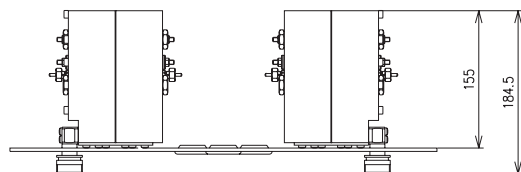

MODULES

MULTIPLEXER MODULE ■ UMTS

Bestell-Nummer Part Number		BN 57 34 56	BN 57 34 55
Ausführung Version		einfach single	zweifach double
Frequenzbereich Frequency range	Tor/port 1	–	1920.3 ... 1930.2 MHz / 2110.3 ... 2120.2 MHz
	Tor/port 2	–	1940.1 ... 1950.0 MHz / 2130.1 ... 2140.0 MHz
	Tor/port 3	–	1959.9 ... 1969.8 MHz / 2149.9 ... 2159.8 MHz
	Tor/port 4	1920.3 ... 1930.2 MHz / 2110.3 ... 2120.2 MHz	1920.3 ... 1930.2 MHz / 2110.3 ... 2120.2 MHz
	Tor/port 5	1940.1 ... 1950.0 MHz / 2130.1 ... 2140.0 MHz	1940.1 ... 1950.0 MHz / 2130.1 ... 2140.0 MHz
	Tor/port 6	1959.9 ... 1969.8 MHz / 2149.9 ... 2159.8 MHz	1959.9 ... 1969.8 MHz / 2149.9 ... 2159.8 MHz
Durchgangsdämpfung Insertion loss		≤ 2.0 dB	
Entkopplung Isolation	Tor/port 1 ↔ Tor/port 2 / 4 ↔ 5 Tor/port 1 ↔ Tor/port 3 / 4 ↔ 6 Tor/port 2 ↔ Tor/port 3 / 5 ↔ 6	≥ 30 dB ≥ 50 dB ≥ 30 dB	
VSWR		≤ 1.2	
Anschlussleistung pro Eingang Power rating per input		≤ 50 W	≤ 50 W
Intermodulation (IM3) 2 x 20 W		≤ -150 dBc; typ. -160 dBc	
Temperaturbereich Temperature range		-5 °C ... +55 °C	
Schutzgrad Degree of protection		IP20	
DC-Verbindung DC by pass		nur extern über zusätzliche DC-Einspeisung only external with BIAS-T	
Anschlüsse (50 Ω) Connection IEC 60169-4		7-16 Kuppler/Socket	
Abmessungen Höheneinheiten Dimensions Rack units		5 (222 mm)	

MULTIPLEXER MODULE ■ UMTS

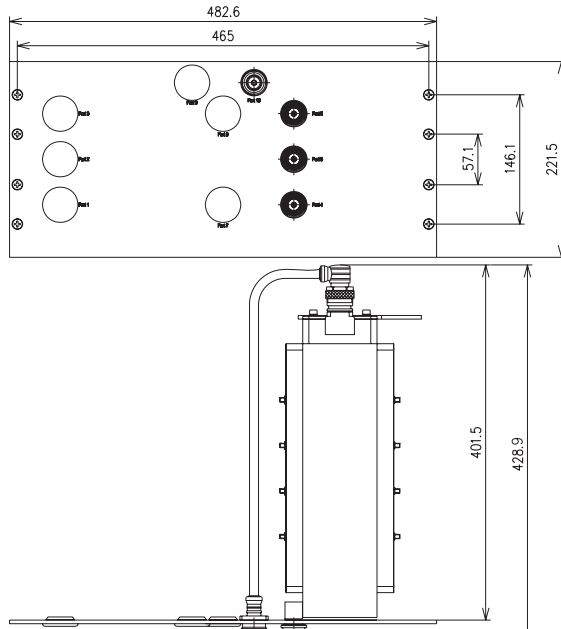

Bestell-Nummer  
Part Number

BN 57 34 56

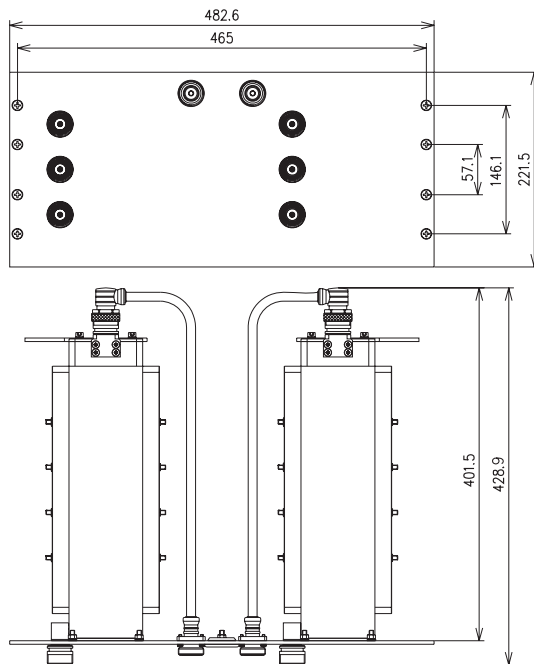

Bestell-Nummer  
Part Number

BN 57 34 55

MODULES

MULTIPLEXER MODULE ■ GSM1800

Bestell-Nummer Part Number		BN 57 34 59	BN 57 34 49
Frequenzbereich Frequency range	Tor/port 1	–	1752.7 ... 1758.1 MHz / 1847.7 ... 1853.1 MHz
	Tor/port 2	–	1725.1 ... 1730.1 MHz / 1820.1 ... 1825.1 MHz
	Tor/port 3	1758.1 ... 1780.5 MHz / 1853.1 ... 1875.5 MHz	1758.1 ... 1780.5 MHz / 1853.1 ... 1875.5 MHz
	Tor/port 4	1730.1 ... 1752.5 MHz / 1825.1 ... 1847.5 MHz	1730.1 ... 1752.5 MHz / 1825.1 ... 1847.5 MHz
Durchgangsdämpfung Insertion loss	Tor/port 1 / 2	≤ 1.7 dB	
	Tor/port 3 / 4	≤ 2.0 dB	
Entkopplung Isolation	Tor/port 1 ↔ Tor/port 2	–	≥ 45 dB
	Tor/port 3 ↔ Tor/port 4	≥ 30 dB	≥ 30 dB
VSWR		≤ 1.2	
Anschlussleistung pro Eingang Power rating per input		≤ 50 W	
Intermodulation (IM3) 2 x 20 W		≤ -150 dBc; typ. -160 dBc	
Temperaturbereich Temperature range		-5 °C ... +55 °C	
Schutzgrad Degree of protection		IP20	
DC-Verbindung DC by pass		nur extern über zusätzliche DC-Einspeisung only external with BIAS-T	
Anschlüsse (50 Ω) Connection IEC 60169-4		7-16 Kuppler/Socket	
Abmessungen Höheneinheiten Dimensions Rack units		5 (222 mm)	

MULTIPLEXER MODULE ■ GSM1800

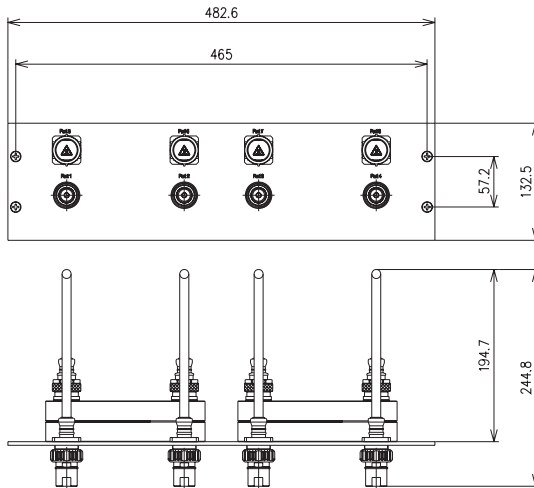

Bestell-Nummer  
Part Number  
BN 57 34 59

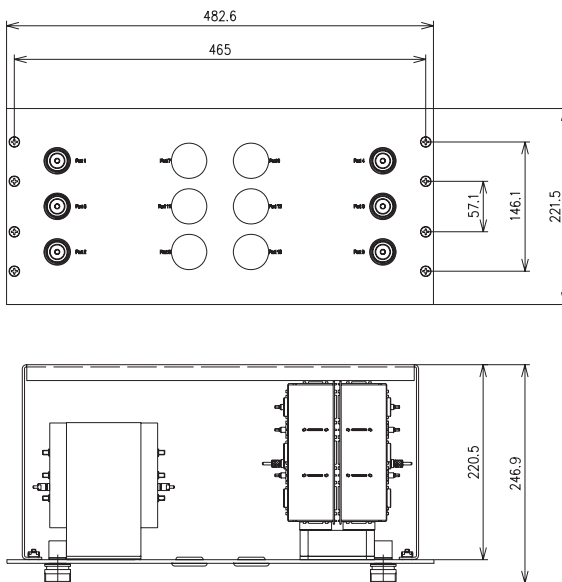

Bestell-Nummer  
Part Number  
BN 57 34 49

MODULES

KOPPLER MODULE ■ COUPLER MODULES

Bestell-Nummer Part Number	BN 57 33 29	BN 57 33 20
Ausführung Version	Hybrid Combiner 4 x 4 4x Breitbandeingang/Broadband input	Zweifach Testkoppler/double test coupler 2 x 2 Testports für/for RX/TX
Frequenzbereich Frequency range	800 ... 2500 MHz	
Durchgangsdämpfung Insertion loss	≤ 6.7 dB	≤ 0.5 dB
Entkopplung Isolation	≥ 28 dB zwischen den Eingängen/between inputs	≥ 50 dB Eingang zu Testport / input to testport
VSWR	≤ 1.12	
Anschlussleistung Power rating	≤ 1000 W	
Intermodulation (IM3) 2 x 20 W	≤ -155 dBc; typ. -160 dBc	
Temperaturbereich Temperature range	-5 °C ... +55 °C	
Schutzgrad Degree of protection	IP20	
Anschlüsse (50 Ω) Connection IEC 60169-4	7-16 Kuppler/Socket	
Abmessungen Höheneinheiten Dimensions Rack units	3 (133 mm)	

KOPPLER MODULE ■ COUPLER MODULES

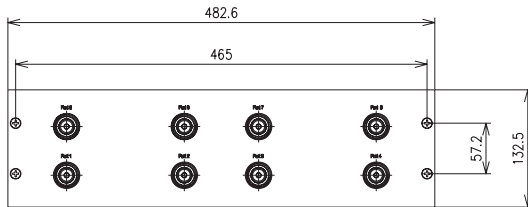

Bestell-Nummer  
Part Number

BN 57 33 29

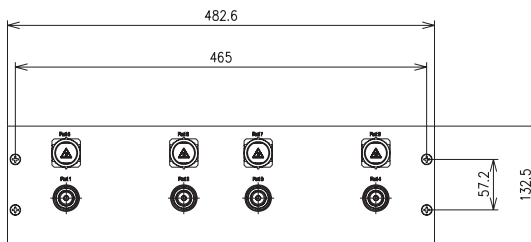
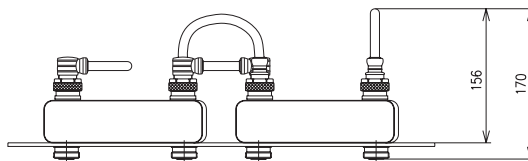

Bestell-Nummer  
Part Number

BN 57 33 20

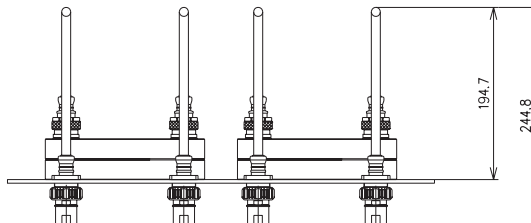

MODULES

DIPLEXER MODULE ■ GSM900 | GSM1800 - UMTS (ZWEIFACH/DOUBLE)

<b>Bestell-Nummer</b> <b>Part Number</b>		<b>BN 57 33 02</b>
Frequenzbereich Frequency range	Tor/port 1 / 4 Tor/port 2 / 5	806 ... 960 MHz 1710 ... 2170 MHz
Durchgangsdämpfung Insertion loss	Tor/port 1 oder/or 4 ↔ Tor/port 3 oder/or 6 Tor/port 2 oder/or 5 ↔ Tor/port 3 oder/or 6	≤ 0.19 dB ≤ 0.22 dB
Entkopplung Isolation		≥ 50 dB
VSWR		≤ 1.2
Anschlussleistung Power rating	Tor/port 1 / 4 Tor/port 2 / 5	≤ 570 W ≤ 380 W
Intermodulation (IM3) 2 x 20 W		≤ -155 dBc; typ. -160 dBc
Temperaturbereich Temperature range		-5 °C ... +55 °C
Schutzgrad Degree of protection		IP20
DC-Verbindung DC by pass		alle Eingänge zum Ausgang all inputs to output
Anschlüsse (50 Ω) Connection IEC 60169-4		7-16 Kuppler/Socket
Abmessungen Höheneinheiten Dimensions Rack units		2 (89 mm)

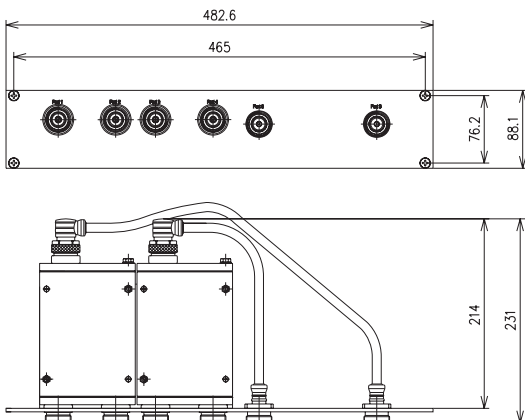



### TRIPLEXER MODULE ■ GSM900 | GSM1800 | UMTS (ZWEIFACH/DOUBLE)

<b>Bestell-Nummer</b> <b>Part Number</b>	<b>BN 57 33 24</b>	
Frequenzbereich Frequency range	Tor/port 1 oder/or 5 Tor/port 2 oder/or 6 Tor/port 3 oder/or 7	806 ... 960 MHz 1710 ... 1880 MHz 1920 ... 2170 MHz
Durchgangsdämpfung Insertion loss	Tor/port 1 oder/or 5 ↔ Tor/port 4 oder/or 8 Tor/port 2 oder/or 6 ↔ Tor/port 4 oder/or 8 Tor/port 3 oder/or 7 ↔ Tor/port 4 oder/or 8	≤ 0.27 dB ≤ 0.42 dB ≤ 0.51 dB
Entkopplung Isolation		≥ 50 dB
VSWR		≤ 1.22
Anschlussleistung Power rating	GSM900 GSM1800 UMTS	≤ 240 W ≤ 240 W ≤ 100 W
Intermodulation (IM3) 2 x 20 W		≤ -155 dBc; typ. -160 dBc
Temperaturbereich Temperature range		-5 °C ... +55 °C
Schutzgrad Degree of protection		IP20
DC-Verbindung DC by pass		alle Eingänge zum Ausgang all inputs to output
Anschlüsse (50 Ω) Connection IEC 60169-4		7-16 Kuppler/Socket
Abmessungen Höheneinheiten Dimensions Rack units		3 (133 mm)

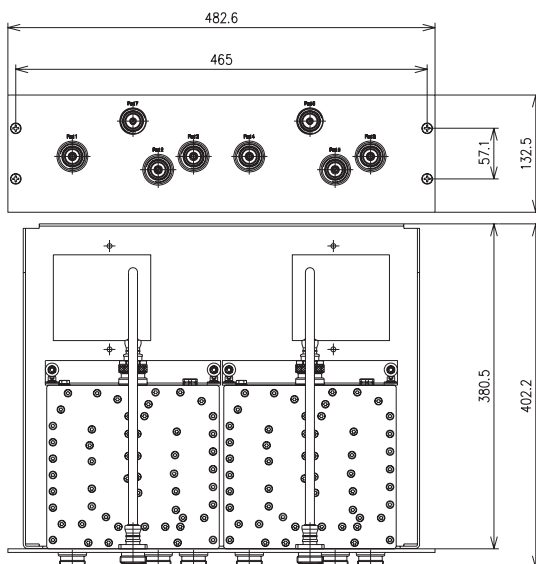

MODULES

UNIVERSAL MODULE ■ 2x GSM900 | 2x GSM1800 | 4x UMTS

Bestell-Nummer Part Number		BN 57 34 50
Frequenzbereich Frequency range	Tor/port 1 / 2 Tor/port 3 / 4 Tor/port 5 Tor/port 6 Tor/port 7 Tor/port 8	890 ... 960 MHz 1710 ... 1880 MHz 1920.3 ... 1930.2 MHz / 2110.3 ... 2120.2 MHz 1969.8 ... 1979.7 MHz / 2159.8 ... 2169.7 MHz 1940.1 ... 1950.0 MHz / 2130.1 ... 2140.0 MHz 1959.9 ... 1969.8 MHz / 2149.9 ... 2159.8 MHz
Durchgangsdämpfung Insertion loss	Tor/port 1-4 ↔ Tor/port 9 / 10 Tor/port 5-8 ↔ Tor/port 9 / 10	≤ 4.0 dB ≤ 6.0 dB
Entkopplung Isolation		≥ 30 dB ≤ 80 dB
VSWR		≤ 1.3
Anschlussleistung Power rating	Tor/port 1-4 Tor/port 5-8	≤ 240 W ≤ 65 W
Intermodulation (IM3) 2 x 20 W		≤ -150 dBc; typ. -160 dBc
Temperaturbereich Temperature range		-5 °C ... +55 °C
Schutzgrad Degree of protection		IP20
DC-Verbindung DC by pass		Tor/port 1 / 3 mit/with Tor/port 9 Tor/port 2 / 4 mit/with Tor/port 10
Anschlüsse (50 Ω) Connection IEC 60169-4		7-16 Kuppler/Socket
Abmessungen Höheneinheiten Dimensions Rack units		5 (222 mm)

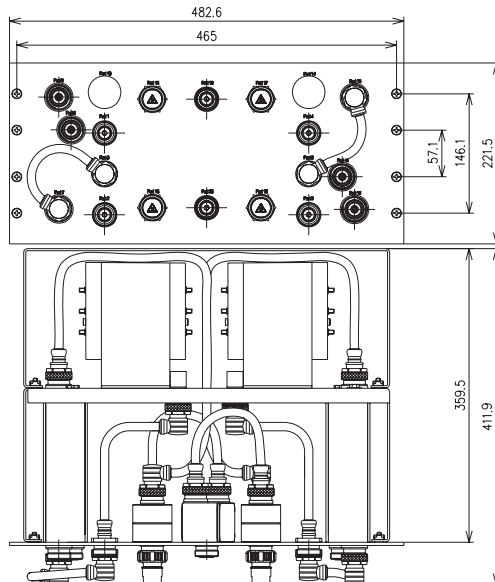

## GESTELLE ■ RACKS

SPINNER produziert die MNCS®-Module als 19" Einschübe, die auf Kundenwunsch in Gestelle montiert werden. Je nach Anzahl und technischer Ausführung stehen fünf verschiedene Gestellgrößen zur Auswahl.

Die Module sind über Jumper Kabel mit den senkrechten Anschlußleisten der Vorderseite verbunden. Die bereits vorinstallierte Verkabelung zum Gestelldach ermöglicht ein einfaches Anschließen der Basisstationen und Antennen. Damit bieten wir unseren Kunden eine übersichtliche und bedienerfreundliche Kabelführung.

SPINNER manufactures the MNCS® modules as 19" inserts that are mounted in racks if requested by customers. Depending on the number and on the technical design five different rack sizes are available.

The modules are connected to the vertical connection bars at the front side by jumper cables. The pre-installed wiring to the rack top makes it simpler to connect ground stations and antennas. Thus we offer our customers a user-friendly wiring system with a good overview.



Abmessungen Dimensions	Bestell-Nummer   Part Number				
	BN A7 23 18	BN A7 23 17	BN A7 23 16	BN A7 23 15	BN A7 23 14
Breite (mm) Wide	598	598	598	598	598
Tiefe (mm) Depth	440	440	440	440	440
Höhe (mm) Height	2300	1730	1330	974	530
Höheneinheiten Rack Units	47	34	25	17	7

**REFERENZEN ■ REFERENCES**

**AIRPORTS**

- Frankfurt/Main International Airport (Germany)
- Düsseldorf International Airport (Germany)
- Hamburg International Airport (Germany)
- Cologne/Bonn International Airport (Germany)
- Luton Airport (UK)
- Vienna International Airport (Austria)



**FAIRGROUNDS**

- Vienna Fairground (Austria)
- Exhibition Ground „Palexpo“ Geneva (Switzerland)
- Cologne Fairground (Germany)
- Berlin Fairground (Germany)
- Düsseldorf Fairground (Germany)



**HOTELS**

- The Intercontinental Berlin (Germany)
- Adlon Kempinski Berlin (Germany)
- Estrel Berlin (Germany)
- Four Seasons Berlin (Germany)
- Sofitel Berlin Schweizerhof (Germany)



**GOVERNMENT BUILDINGS**

- Home of Chancellor Berlin (Germany)
- Parliament Berlin (Germany)
- Parliament – Home of President Berlin (Germany)

**OFFICE BUILDINGS**

- Vodafone Headquarter Düsseldorf (Germany)
- Government- Press and Information Office Berlin (Germany)
- Keppler Bay Tower (Singapore)
- Parkview Square Building (Singapore)
- New Stock Market Berlin (Germany)
- Telia Headquarters (Sweden)
- Berlin Convention Center (Germany)
- Beisheim Center Berlin (Germany)
- BMW Event Center Munich (Germany)
- UNO Campus Bonn (Germany)



**SHOPPING MALLS**

- Meadow Hall Shopping Center (UK)
- Shopping Mall Münster Arcadia (Germany)
- Shopping Mall Riem Arcadia Munich (Germany)
- Shopping Mall Schönhauser Arcadia Berlin (Germany)
- Shopping Mall Wuppertal Arkadia (Germany)
- Europapassage Hamburg (Germany)

**STADIA**

- Berlin Olympic Stadium (Germany)
- Rhein-Energie-Stadium Düsseldorf (Germany)
- Mönchengladbach Soccer Stadium (Germany)
- MSV Duisburg Soccer Stadium (Germany)
- Hannover 96 Soccer Stadium (Germany)

**TRANSPORTATION**

- Linz Traffic Tunnel (Austria)
- Vienna Subway (Austria)
- Stuttgart Railway Tunnel (Germany)
- Paris Subway (France)
- Hanover Main Station (Germany)
- Cologne Subway (Germany)

## SYSTEM SOLUTION

### METRO PARIS ■ PARIS METRO

Mit ca. 222 km Gleislänge und 380 Stationen hat die Pariser Metro das drittgrößte U-Bahn-Netz in Europa. Täglich nutzen etwa 9 Millionen Passagiere dieses Verkehrsmittel. Verständlich, dass der Verkehrsbetrieb RATP (Regie Autonome des Transports Parisiens) großes Interesse an zufriedenen Fahrgästen hat, was auch die funktechnische Erschließung des Streckennetzes einschließt.

Alle drei Hauptnetzbetreiber bieten ihren Service an, wobei in der ersten Phase vorrangig GSM900 und GSM1800 Funkversorgung realisiert wurde.

SPINNER konnte mit einfachen, aber zuverlässigen Lösungen überzeugen und die bis dahin installierte Technik ersetzen.

The Paris underground rail system has about 222 km of track and 380 stations, making it the third largest underground network in Europe.

Some 9 million passengers use this means of transport every day. It is understandable that the transport board, RATP (Regie Autonome des Transports Parisiens) is interested in satisfied passengers, and that also includes radio coverage of the network.

All three main network operators offer their service. In the first phase it was mainly GSM900 and GSM1800 coverage that was implemented.

SPINNER presented convincingly simple and reliable solutions and could replace the technology formerly used.

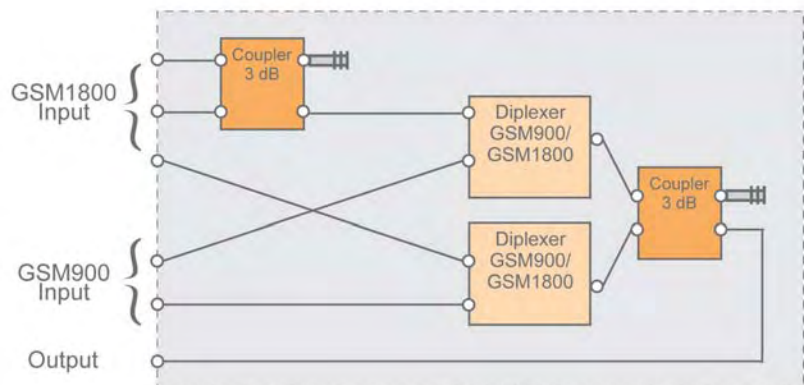

Diplexer - Coupler - Version

Grundvariante:  
3x GSM1800  
2x GSM900  
auf 1 gemeinsamen Ausgang

Basic variant:  
3x GSM1800  
2x GSM900  
on 1 common output

Die Komponenten werden auf einer Platte montiert und in die vorhandene Technik integriert.

The components are mounted on a panel and integrated with the existing equipment.

## SYSTEM SOLUTION

### OLYMPIASTADION BERLIN ■ BERLIN OLYMPIC STADIUM

In diesem Stadion mit 76.000 Sitzplätzen fand im Juli 2006 das Endspiel der Fußball Weltmeisterschaft statt. SPINNER hat die Lösung für die Funkversorgung des Stadions im Innen- und Außenbereich geliefert. Das System wird gemeinsam von T-Mobile, Vodafone, O2 und E-Plus Deutschland in den Frequenzbändern GSM900, GSM1800 und UMTS genutzt. Geringer Platz in den Technikräumen führte zu kompakten Wandmontagelösungen. SPINNER lieferte eine große Anzahl verschiedener Schrankvarianten.

This is the stadium with 76,000 seats where the final match of the football world cup was played in July 2006. SPINNER provided the solution for radio coverage of the inner and outer areas of the stadium. T-Mobile, Vodafone, O2 and E-Plus Deutschland jointly use the system in the GSM900, GSM1800 and UMTS frequency bands. Since only very limited space was available in the equipment rooms we developed compact wall-mounted solutions. SPINNER supplied a large number of different rack variants.

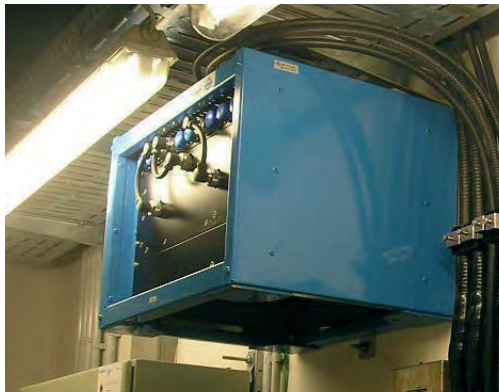

MNCS®-Schrank im Innenbereich  
MNCS® rack as compact wall-mounted solution



Antennenstandorte / Antenna sites



### OLYMPIASTADION BERLIN ■ BERLIN OLYMPIC STADIUM

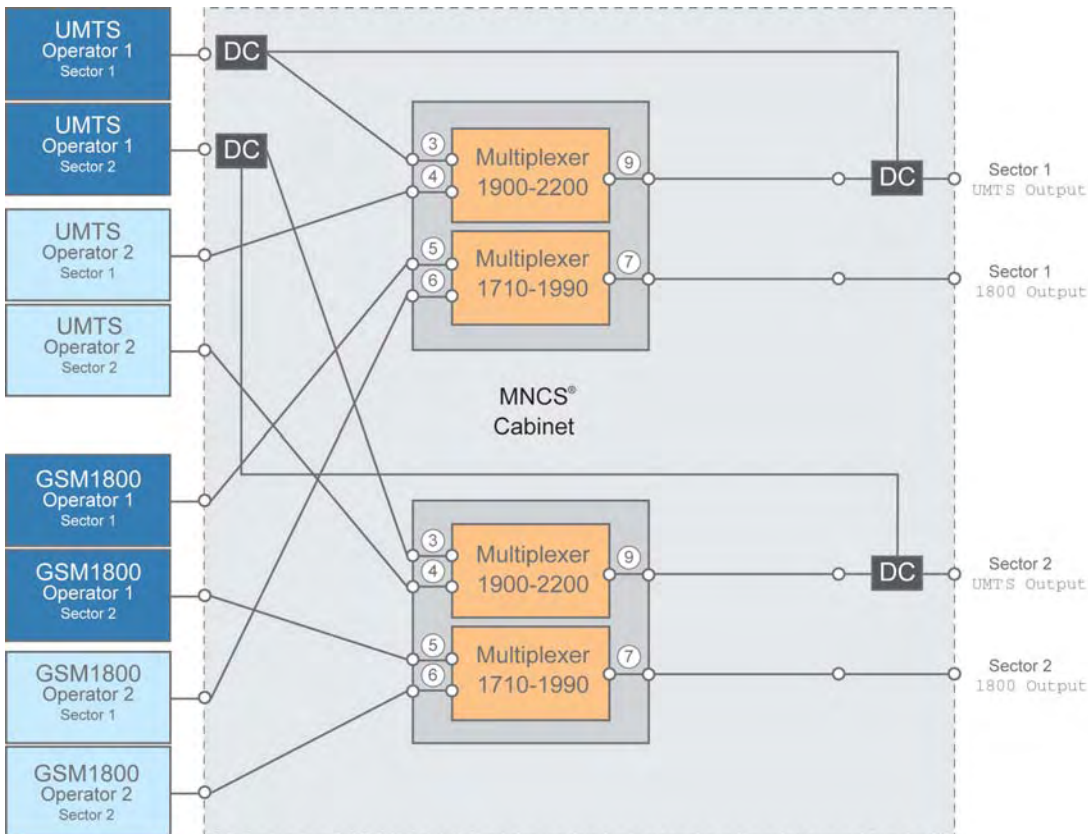

Zusammenschaltung von:  
UMTS/GSM1800 Frequenzbändern von 2 Netzbetreibern  
mit je 2 Sektoren

2 gemeinsame Sektoren – Ausgänge GSM1800  
2 gemeinsame Sektoren – Ausgänge UMTS (W-CDMA) mit  
gemeinsamem TMA

MNCS®-Schrank  
Alle Ein-/Ausgänge (7-16 Kuppler) auf dem Schrankdach  
angeordnet.

Lösung zur Funkabdeckung im Bereich der riesigen Leinwand  
im Zentrum des Stadions.  
Die SPINNER Multiplexer-Technologie bietet sehr geringe  
Einfügedämpfungen, extrem geringe Intermodulation  
(-155 dBc garantiert) sowie hervorragende Signalisolation.

Combining:  
UMTS/GSM1800 frequency bands of 2 network operators  
with 2 sectors each

2 common sector outputs for GSM1800  
2 common sector outputs for UMTS (W-CDMA) with a  
common TMA

MNCS® rack  
All inputs/outputs (7-16 couplers) located on the rack top.

Solution for radio coverage of the area near the huge  
screen in the centre of the stadium.  
SPINNER multiplexer technology offers very low insertion  
loss, extremely low intermodulation values  
(-155 dBc guaranteed) as well as excellent signal isolation.

## SYSTEM SOLUTION

### BUNDESJUSTIZMINISTERIUM BERLIN ■ FEDERAL MINISTRY OF JUSTICE BERLIN

SPINNER konnte in den letzten Jahren bei der Funkversorgung aller wichtigen Regierungsbauten in Berlin mitwirken. Neben dem Justizministerium so auch beim Bundespräsidialamt, dem Reichstag, dem Bundeskriminalamt, dem Bundespresseamt, dem Bundesministerium für Bildung, dem Auswärtige Amt oder dem Innenministerium um nur einige zu nennen.

Bei der Zusammenschalteneinrichtung für das Justizministerium wurden GSM900, GSM1800 und UMTS Frequenzbänder zusammengeführt. Es handelt sich um einen Außenstandort auf dem Dach des Gebäudes. Das Projekt vereint 4 UMTS, 2 GSM1800 und 1 GSM900-Betreiber mit gesamt 10 Sektoren, die auf einen gemeinsamen Ausgang geführt werden.

Over the last years SPINNER could make a contribution to the radio coverage of all important government buildings in Berlin. This includes the Ministry of Justice, the President's Office, the Parliament, the Federal Criminal Police Office, the Federal Press Office, the Ministry of Education, the Foreign Office and the Ministry of the Interior, to mention but a few.

The combination system for the Ministry of Justice was used to combine the frequency bands of GSM900, GSM1800 and UMTS. The system location is outdoors on the roof of the building. The projects includes 4 UMTS, 2 GSM1800 and 1 GSM900 service operators with a total of 10 sectors, all combined on one common output.



Dachstandort mit Systemtechnik und Zusammenschalteneinrichtung outdoor-fähig im Shelter installiert.  
Roof site with systems technology and combination system installed in shelter outdoor.



Kabelanschlüsse / Cable connections



### BUNDESJUSTIZMINISTERIUM BERLIN ■ FEDERAL MINISTRY OF JUSTICE BERLIN

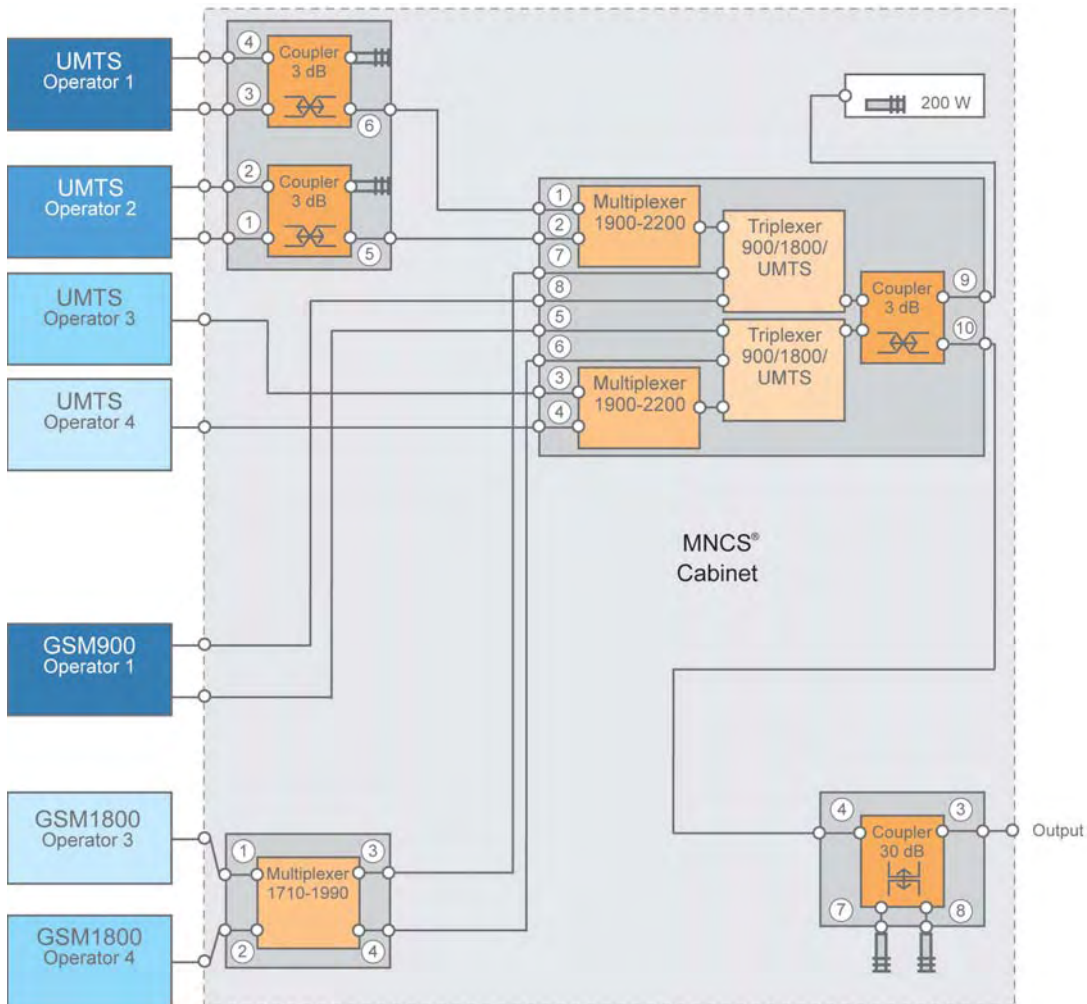

Zusammenschaltung von:  
4 UMTS, 2 GSM1800 und 1 GSM900 Netzen auf  
1 gemeinsamen Ausgang.

MNCS®-Schränk  
Alle Ein-/Ausgänge (7-16 Kuppler) am Schrankboden nach  
unten abgehend angeordnet.

Combining:  
4 UMTS, 2 GSM1800 and 1 GSM900 service on  
1 common output.

MNCS® rack  
All inputs/outputs (7-16 couplers) located at the rack  
bottom with connections pointing down.

## SYSTEM SOLUTION

### MESSE KÖLN NORD & KONGRESSZENTRUM ■ NORTHERN COLOGNE FAIRGROUND & CONGRESS CENTER

Im Januar 2006 wurde die neue Messe Köln pünktlich zur internationalen Möbelmesse eröffnet. In nur 16 Monaten Bauzeit sind vier neue, moderne Messehallen mit neuem Kongresszentrum entstanden. Mit 284.000 m<sup>2</sup> Ausstellungsfläche bleibt sie das viertgrößte Messegelände der Welt. SPINNER wurde beauftragt für die Hallen 8 bis 11 sowie das Kongresszentrum die Zusammenschaltanlagen für 4 Mobilfunkbetreiber zu liefern.

Je nach Standort waren 16 UMTS, 4 GSM1800 und 4 GSM900 Sektoren bzw. 8 UMTS, 2 GSM1800 und 2 GSM900 Sektoren zusammenzuführen. Zwei verschiedene Schrankkonfigurationen wurden entwickelt und jeweils 4 Schränke geliefert.

In January 2006 the new Cologne exhibition grounds were opened, perfectly in time for the international furniture fair. It took only 16 months of building time to create four new, modern trade fair pavilions including a new conference centre. 284,000 m<sup>2</sup> of exhibition area make the place the fourth largest exhibition centre of the world. SPINNER was asked to supply the combiner systems for 4 mobile communication service operators for pavilions 8 to 11 and for the conference centre.

Depending on the locations the task was to combine either 16 UMTS, 4 GSM1800 and 4 GSM900 sectors or 8 UMTS, 2 GSM1800 and 2 GSM900 sectors.

We developed two different rack configurations and delivered 4 racks of each type.



Container für Systemtechnik / Container for systems technology



Messehalle / Exhibition hall

MESSE KÖLN NORD & KONGRESSZENTRUM ■ NORTHERN COLOGNE FAIRGROUND & CONGRESS CENTER

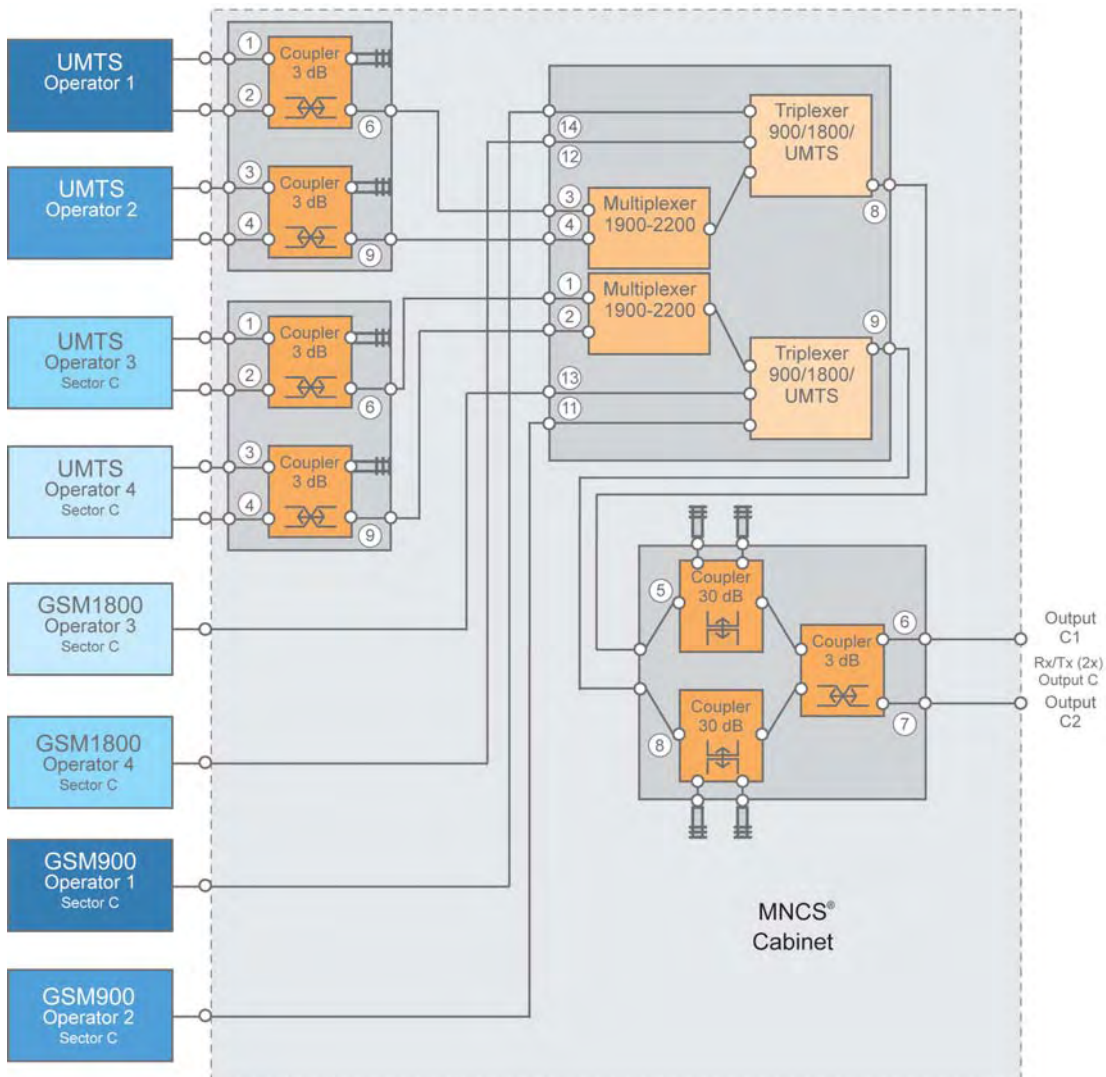

Zusammenschaltung von:  
4 UMTS, 2 GSM1800 und 2 GSM900 Netzen auf  
2 gemeinsame Ausgänge.

MNCS®-Schrank  
Alle Ein-/Ausgänge (7-16 Kuppler) auf dem Schrankdach  
angeordnet.

Combining:  
4 UMTS, 2 GSM1800 and 2 GSM900 networks  
on 2 common outputs.

MNCS® rack  
All inputs/outputs (7-16 couplers) located on the  
rack top.

SYSTEM SOLUTION

HAMBURG FLUGHAFEN ■ HAMBURG AIRPORT

Hamburg hat den größten internationalen Flughafen Norddeutschlands. Mit fast 12 Millionen Passagieren und über 160.000 Flugbewegungen pro Jahr ist er der viertgrößte Flughafen Deutschlands. Etwa 70 Fluggesellschaften verbinden Hamburg mit ca. 120 Zielen weltweit. Ständige Erweiterungen machen den Flughafen noch attraktiver für in- und ausländische Besucher.

SPINNER erhielt den Auftrag für die Funkversorgung des Terminals 2 die Zusammenschaltanlage für vier Mobilfunkbetreiber zu liefern. Eine nicht einfache Aufgabe, da es immerhin galt zwanzig UMTS, zwölf GSM1800 und acht GSM900 Sektoren auf 13 Antennenstandorte entsprechend den technischen und örtlichen Anforderungen zu führen.

Hamburg is the largest international airport in North Germany. Almost 12 million passengers and more than 160,000 take-offs and landings per year make it the fourth largest airport in Germany. About 70 airlines are offering services to connect Hamburg to some 120 destinations world-wide. Continuous expansion makes the airport even more attractive for domestic and foreign visitors.

SPINNER received the order to supply the combining systems for 4 mobile communication service operators in order to ensure the wireless coverage of Terminal 2. The task was not too easy to resolve because it meant to route twenty UMTS, twelve GSM1800 and eight GSM900 sectors to 13 antenna sites in line with the local technical requirements.



SPINNER konnte die Aufgabe souverän lösen und lieferte drei MNCS®-Schränke.  
 SPINNER mastered that task perfectly and delivered three MNCS® racks.

Zusammenschaltung von:  
 4 UMTS, 1 GSM1800 und 2 GSM900 Netzen.

Combining:  
 4 UMTS, 1 GSM1800 and 2 GSM900 networks.

SYSTEM SOLUTION

HAMBURG FLUGHAFEN ■ HAMBURG AIRPORT

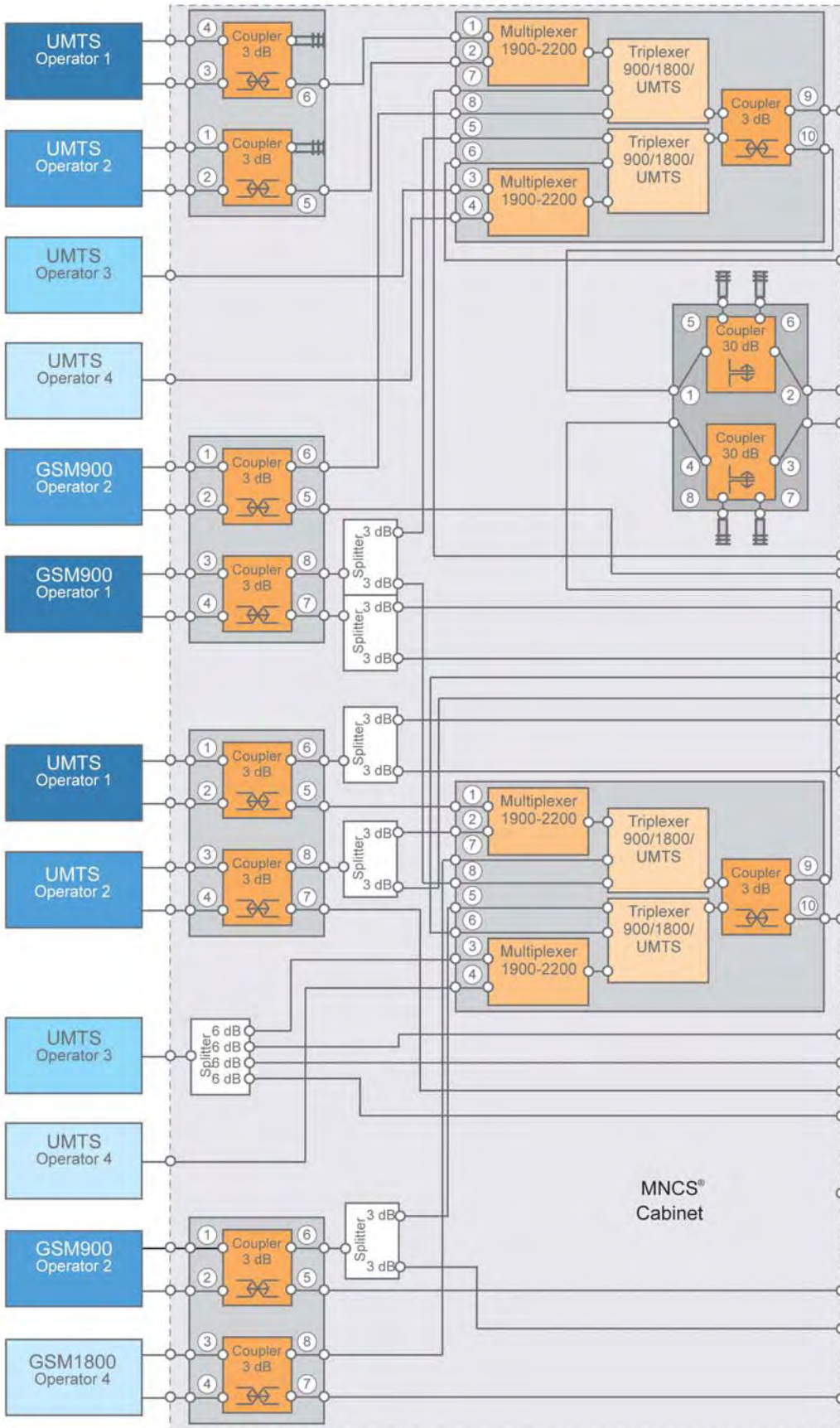

# PROJEKT-SPEZIFIKATION MNCS® | PROJECT SPECIFICATION MNCS®

Kontaktdaten | Contact details: \_\_\_\_\_

Firma | Company: \_\_\_\_\_

E-Mail: \_\_\_\_\_ @ \_\_\_\_\_

Datum | Date: \_\_\_\_\_

Projekt | Project: \_\_\_\_\_

## Technische Daten | Technical Data

Frequenzbereich (MHz) Frequency range		Empfangsfrequenz RX Frequency	Sendefrequenz TX Frequency	Leistung pro Eingang Power per port
Bereich1 Range 1	Tor/Range 11			
	Tor/Range 12			
	Tor/Range 13			
	Tor/Range 14			
Bereich2 Range 2	Tor/Range 21			
	Tor/Range 22			
	Tor/Range 23			
	Tor/Range 24			
Bereich3 Range 3	Tor/Range 31			
	Tor/Range 32			
	Tor/Range 33			
	Tor/Range 34			
Bereich4 Range 4	Tor/Range 41			
	Tor/Range 42			
	Tor/Range 43			
	Tor/Range 44			
Bereich5 Range 5	Tor/Range 51			
	Tor/Range 52			
	Tor/Range 53			
	Tor/Range 54			
Bereich6 Range 6	Tor/Range 61			
	Tor/Range 62			
	Tor/Range 63			
	Tor/Range 64			

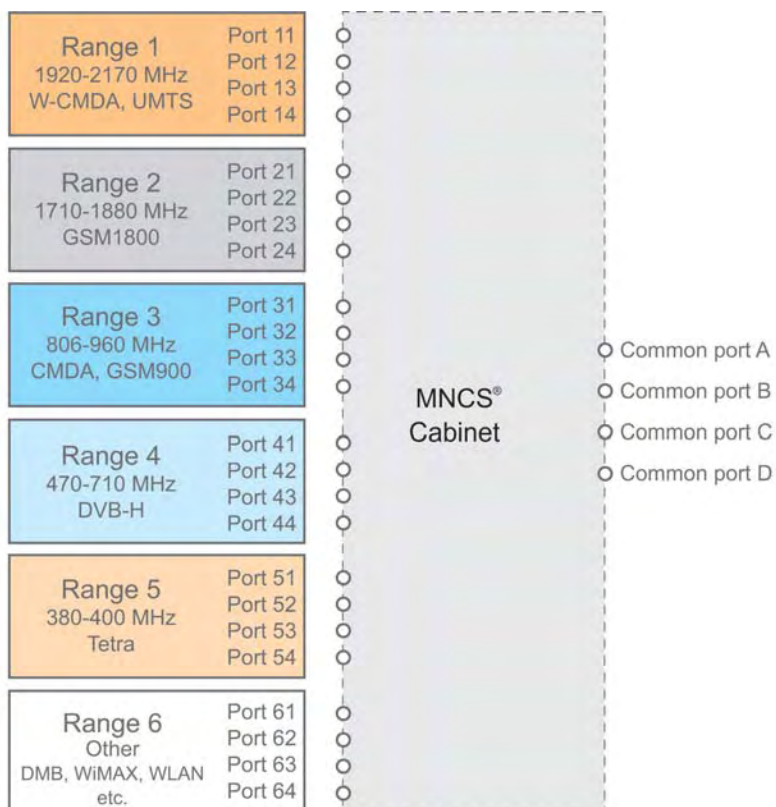

	SPINNER Standard		Andere Spezifikationen Other specifications	
Anzahl der Ausgänge Number of common ports	<input type="checkbox"/> 2	<input type="checkbox"/> 4		
Isolation Interband zwischen den Frequenzbereichen between frequency range	≥ 50 dB			
Isolation Inband zwischen den Toren eines Frequenzbereiches between ports within frequency range	≥ 30 dB			
Intermodulation (IM3) 2 x 20 W alle Bereiche, Tore / all ranges, ports	≤ -155 dBc; typ. -160 dBc			
DC/AISG Verbindung DC/AISG pass	-			
Anschlüsse (50 Ω) Connection	7-16 Kuppler/Socket (IEC 60169-4) auf dem Schrankdach/top of rack			
Abmessungen (Breite x Tiefe) Dimensions (wide x depth)	598 mm x 440 mm			
Höheneinheiten Rack units	<input type="checkbox"/> 7	<input type="checkbox"/> 17	<input type="checkbox"/> 25	<input type="checkbox"/> 34 <input type="checkbox"/> 47

**Weitere Spezifikationen | Additional Specification:**

## GENERAL TECHNICAL INFORMATION

### VSWR / Reflexionsfaktor

Wenn eine elektrische Leitung mit ihrem Wellenwiderstand abgeschlossen ist, dann wird ein darauf übertragenes Signal vollständig am Abschlusswiderstand absorbiert. Weicht die Impedanz des Abschlusses jedoch vom Wellenwiderstand der Leitung ab, so kommt es zu einer mehr oder weniger starken Reflexion der Welle.

Der Reflexionsfaktor  $r$  ist über die Beziehung:

$$r = \frac{Z - Z_0}{Z + Z_0}$$

mit dem komplexen Wellenwiderstand der Leitung  $Z_0$  und dem komplexen Abschlusswiderstand  $Z$  verbunden. Die auf der Leitung vorlaufenden und reflektierten Wellen überlagern sich dabei zu stehenden Wellen. Das Amplitudenverhältnis der größten und kleinsten Spannung auf einer verlustlosen Leitung ist als Stehwellen-Verhältnis oder VSWR (Voltage Standing Wave Ratio) definiert:

$$\text{VSWR} = \frac{1 + |r|}{1 - |r|}$$

Der Reflexionsfaktor wird oft auch im logarithmischen Maß der Rückflussdämpfung  $\alpha$  angegeben:

$$\alpha = -20 \log(r) \text{ dB}$$

### Intermodulation

Werden über eine Leitung gleichzeitig mehrere Trägerfrequenzkanäle geführt, entstehen durch nichtlineare Kennlinien von Bauteilen im Signalpfad Störsignale in Form von Mischprodukten.

Die Entstehung dieser neuen, unerwünschten Signale wird Intermodulationsprodukt (IM-Produkt) genannt. Die Frequenz der IM-Signale errechnet sich aus den verwendeten Trägerfrequenzen über folgende Formel:

$$f_{\text{IMx}} = af_1 \pm bf_2 \pm \dots \pm mf_z$$

Zur Messung der IM-Güte eines passiven HF-Bauteils werden 2 Signale mit festgelegtem gleichem Leistungspegel und den Frequenzen  $f_1$  und  $f_2$  in den Prüfling eingespeist.

Die IM-Signale der Ordnung 2 (IM2:  $f_1 \pm f_2$ ), Ordnung 3 (IM3:  $2f_1 \pm f_2$ ) oder höherer Ordnung können dann mit einem Empfänger gemessen werden.

Obwohl moderne Mobilfunksysteme durch die Wahl der Sende- bzw. Empfangsfrequenzbereiche eine Störung durch die betragsgrößten IM-Signale (IM2) ausschließen, kann das Auftreten von IM-Produkten höherer Ordnung (IM3, IM5, IM7,...) in Nutzbändern nicht vermieden werden.

### VSWR / reflection factor

When an electrical line is terminated by a load with its characteristic impedance a signal transmitted to the line is fully absorbed by the matching load. However, if the impedance of the termination differs from the characteristic impedance of the line the wave will be reflected more or less strongly.

The reflection factor  $r$  is related to the complex impedance of the line,  $Z_0$ , and the complex terminating impedance,  $Z$ :

$$r = \frac{Z - Z_0}{Z + Z_0}$$

The waves continuing along the line and reflected waves are overlaying to form standing waves. The amplitude relationship between the largest and the smallest voltage on a loss-free line is defined as the VSWR (Voltage Standing Wave Ratio):

$$\text{VSWR} = \frac{1 + |r|}{1 - |r|}$$

The reflection factor is often specified as the logarithmic value of the return loss:

$$\alpha = -20 \log(r) \text{ dB}$$

### Intermodulation

If several carrier frequency channels are fed through a single line at the same time the non-linear parameters of components in the signal path create mixed products, i. e. noise signals.

The emergence of these new undesirable products is called the intermodulation product. The frequency of such IM signals can be calculated from the carrier frequencies using the following formula:

$$f_{\text{IMx}} = af_1 \pm bf_2 \pm \dots \pm mf_z$$

The IM quality of passive RF components is measured by feeding two signals with a defined identical power level at frequencies  $f_1$  and  $f_2$  into the test component. Then a receiver is used to measure the second order (IM2:  $f_1 \pm f_2$ ), third order (IM3:  $2f_1 \pm f_2$ ) or higher order IM signals.

Modern mobile communication systems select the transmission and reception frequency range properly to rule out interference from the strongest IM signals (IM2). However, the occurrence of higher order IM products (IM3, IM5, IM7,...) in the used bands cannot be prevented.

So in most cases the third order IM products represent



## GENERAL TECHNICAL INFORMATION

In den meisten Fällen stellen deshalb die IM-Signale der dritten Ordnung den „worst case“ Zustand dar und werden daher als Maß für die IM-Güte eines HF-Bauteils verwendet.

Die beeinflussenden Faktoren der IM-Verzerrung im Fall passiver HF-Bauelemente sind die verwendeten Werkstoffe, intermetallische Kontakte, Kontaktkräfte, Kontaktflächen, Korrosion, Oxidschichten oder Schmutz.

Die Höhe eines gemessenen IM-Produkts ist darüber hinaus abhängig von Vibration, Bewegung oder anderen Umwelteinflüssen. Außerdem treten Langzeitveränderungen durch mechanische Beanspruchung, Temperatur- oder Klimaschwankungen auf.

### Dämpfungen und Verstärkungen

Dämpfung ist die Minderung der übertragenen Energie eines Signals im Verlauf einer Übertragungsstrecke. Eine Dämpfung ist demzufolge eine negative Verstärkung. Dämpfungen oder Verstärkungen werden im Allgemeinen in dB (Dezibel) angegeben. Angaben in dB sind „relative Pegel“. Der Begriff „Pegel“ steht für den Vergleich zwischen einer gemessenen Größe und einer Bezugsgröße:

Der relative Pegel einer Übertragungsstrecke ist folgendermaßen definiert:

Man setzt den Pegel eines Bezugspunktes, zum Beispiel den Ort der Einspeisung, zu 0 dB, unabhängig vom dort aktuellen Absolutpegel. Der relative Pegel am Ende der Strecke ergibt sich dann durch Addition von Bezugspegel und sämtlichen Übertragungsmaßen der Übertragungsglieder der Strecke (positiv für Verstärker, negativ für Dämpfungsglieder).

### Umrechnung dBm in Watt / Translation dBm into Watt

+90dBm	1.000.000 W	$10^6$	1 Megawatt
+80dBm	100.000 W	$10^5$	100 Kilowatt
+70dBm	10.000 W	$10^4$	10 Kilowatt
+60dBm	1.000 W	$10^3$	1 Kilowatt
+50dBm	100 W	$10^2$	100 Watt
+40dBm	10 W	$10^1$	10 Watt
+30dBm	1 W	$10^0$	1 Watt
+20dBm	0.1 W	$10^{-1}$	100 Milliwatt
+10dBm	0.01 W	$10^{-2}$	10 Milliwatt
0dBm	0.001 W	$10^{-3}$	1 Milliwatt
-10dBm	0.0001 W	$10^{-4}$	100 Microwatt
-20dBm	0.00001 W	$10^{-5}$	10 Microwatt
-30dBm	0.000001 W	$10^{-6}$	1 Microwatt
-40dBm	0.0000001 W	$10^{-7}$	100 Nanowatt
-50dBm	0.00000001 W	$10^{-8}$	10 Nanowatt
-60dBm	0.000000001 W	$10^{-9}$	1 Nanowatt

Therefore, in the majority of cases third order IM signals show the “worst case”, which is used to measure the IM quality of RF components.

The factors influencing IM distortion in passive RF components are the materials employed, intermetal contact, contact forces, contact areas, corrosion, oxide layers, or dirt. The strength of the measured IM product further depends on vibration, movement and other environmental influences. In addition long-term changes may occur due to mechanical load and temperature or climate fluctuation.

### Attenuation and amplification

Attenuation is defined as the reduction of the transmitted energy of a signal in the course of a transmission link. Thus attenuation is negative amplification. Attenuation and amplification are usually specified in dB (decibel). Specifications in dB are "relative levels". Here the notion "level" means the comparison between a measured value and a reference value:

The relative level of a transmission link is defined as follows: The level at a reference point, e. g. at the feeding point, is defined as 0 dB, regardless of the actual absolute level. The relative level at the end of the link is derived by adding the reference level and all transmission parameters of the elements of the transmission link (positive for amplifiers, negative for attenuation links).

## GENERAL TECHNICAL INFORMATION

### Schutzgrad und IP-Kennzeichnung

In der Norm DIN EN 60529:1991 werden Begriffe für Schutzarten durch Gehäuse von elektrischen Betriebsmittel festgelegt. Um die Schutzgrade durch ein Gehäuse anzugeben wird der IP-Code benutzt z. B.:

**IP 23 CH**; IP = International Protection (Ingress Protection)

#### IP 2 3 C H

0-6 oder X – Gegen Eindringen von festen Fremdkörpern  
*0-6 or X – against ingress of solid objects*

- 0 nicht geschützt/*no special protection*
- 1  $\geq 50,0$  mm  $\varnothing$
- 2  $\geq 12,5$  mm  $\varnothing$
- 3  $\geq 2,5$  mm  $\varnothing$
- 4  $\geq 1,0$  mm  $\varnothing$
- 5 staubgeschützt/*dust protection*
- 6 staubdicht/*dust tight*

X ersetzt die Kennziffer, falls keine Angabe notwendig/  
*X replaces numeral if not applicable*

### Degree of Protection and IP Classification

Standard DIN EN 60529:1991 defines the protection ratings for the housings of electrical appliances. The IP code is used for specifying the protection rating of a housing, e. g.:

**IP 23 CH**; IP = International Protection (Ingress Protection)

#### IP 2 3 C H

fakultativ – A,B,C,D – Gegen Zugang zu gefährlichen Teilen mit Fremdkörpern  
*optional – A,B,C,D – against access to hazardous parts*

- A Handrücken/*back of hand*
- B Finger/*finger*
- C Werkzeug/*tool*
- D Draht/*wire*

#### IP 2 3 C H

0-8 oder/or X – Gegen Eindringen von Wasser/*against ingress of water*

- 0 nicht geschützt/*no special protection*
- 1 senkrecht Tropfen/*vertically dripping*
- 2 Tropfen (15° Neigung)/*dripping (15° tilted)*
- 3 Sprühwasser/*spraying*
- 4 Spritzwasser/*splashing*
- 5 Strahlwasser/*jetting*
- 6 starkes Strahlwasser/*powerful jetting*
- 7 zeitweiliges Untertauchen/*temporary immersion*
- 8 dauerndes Untertauchen/*continuous immersion*

X ersetzt die Kennziffer, falls keine Angabe notwendig/  
*X replaces numeral if not applicable*

#### IP 2 3 C H

fakultativ – H, M, S, W – Ergänzende Informationen speziell für/  
*optional – H, M, S, W – supplementary information specific for*

- H Hochspannungsgeräte/*high voltage equipment*
- M Bewegung während Wasserprüfung/  
*motion during water test*
- S Stillstand während Wasserprüfung/  
*stationary during water test*
- W Wetterbedingungen/*weather conditions*



VSWR CONVERSION TABLE

VSWR	Reflection (r)	Return loss (dB)
1,010	0,005	46,1
1,015	0,007	42,6
1,020	0,010	40,1
1,025	0,012	38,2
1,030	0,015	36,6
1,035	0,017	35,3
1,040	0,020	34,2
1,045	0,022	33,1
1,050	0,024	32,3
1,055	0,027	31,4
1,060	0,029	30,7
1,065	0,031	30,0
1,070	0,034	29,4
1,075	0,036	28,8
1,080	0,038	28,3
1,085	0,041	27,8
1,090	0,043	27,3
1,095	0,045	26,9
1,100	0,048	26,4
1,110	0,052	25,7
1,120	0,057	24,9
1,130	0,061	24,3
1,140	0,065	23,7
1,150	0,070	23,1
1,160	0,074	22,6
1,170	0,078	22,1
1,180	0,083	21,7
1,190	0,087	21,2
1,200	0,091	20,8
1,210	0,095	20,4
1,220	0,099	20,1
1,230	0,103	19,7
1,240	0,107	19,4
1,250	0,111	19,1
1,260	0,115	18,8
1,270	0,119	18,5
1,280	0,123	18,2
1,290	0,127	17,9
1,300	0,130	17,7
1,310	0,134	17,4
1,320	0,138	17,2
1,330	0,142	17,0
1,340	0,145	16,8
1,350	0,149	16,5
1,360	0,153	16,3
1,370	0,156	16,1
1,380	0,160	15,9
1,390	0,163	15,7
1,400	0,167	15,6
1,410	0,170	15,4
1,420	0,174	15,2

VSWR	Reflection (r)	Return loss (dB)
1,430	0,177	15,0
1,440	0,180	14,9
1,450	0,184	14,7
1,460	0,187	14,6
1,470	0,190	14,4
1,480	0,194	14,3
1,490	0,197	14,1
1,500	0,200	14,0
1,510	0,203	13,8
1,520	0,206	13,7
1,530	0,209	13,6
1,540	0,213	13,4
1,550	0,216	13,3
1,560	0,219	13,2
1,570	0,222	13,1
1,580	0,225	13,0
1,590	0,228	12,8
1,600	0,231	12,7
1,610	0,234	12,6
1,620	0,237	12,5
1,630	0,240	12,4
1,640	0,242	12,3
1,650	0,245	12,2
1,660	0,248	12,1
1,670	0,251	12,0
1,680	0,254	11,9
1,690	0,257	11,8
1,700	0,259	11,7
1,710	0,262	11,6
1,720	0,265	11,5
1,730	0,267	11,5
1,740	0,270	11,4
1,750	0,273	11,3
1,760	0,275	11,2
1,770	0,278	11,1
1,780	0,281	11,0
1,790	0,283	11,0
1,800	0,286	10,9
1,810	0,288	10,8
1,820	0,291	10,7
1,830	0,293	10,7
1,840	0,296	10,6
1,850	0,298	10,5
1,860	0,301	10,4
1,870	0,303	10,4
1,880	0,306	10,3
1,890	0,308	10,2
1,900	0,310	10,2
1,910	0,313	10,1
1,920	0,315	10,0
1,930	0,317	10,0

Auf unserer Webseite finden Sie einen VSWR-Rechner zum Download.  
 On our website you will find a VSWR converter tool under the Downloads section.



<b>Bestell-Nr. Part-No.</b>	<b>Seite Page</b>	<b>Bestell-Nr. Part-No.</b>	<b>Seite Page</b>	<b>Bestell-Nr. Part-No.</b>	<b>Seite Page</b>
BN 07 05 51.....	35	BN 53 38 44.....	36	BN 57 33 02.....	144
BN 15 05 97.....	35	BN 53 38 45.....	36	BN 57 33 20.....	142
BN 15 16 71.....	35	BN 53 38 46.....	36	BN 57 33 24.....	145
BN 19 42 82.....	57	BN 53 42 77.....	88	BN 57 33 29.....	142
BN 19 42 84.....	57	BN 53 42 79.....	88	BN 57 34 49.....	140
BN 19 44 00.....	34	BN 53 42 80.....	88	BN 57 34 50.....	146
BN 19 64 00.....	32	BN 53 43 61.....	96	BN 57 34 51.....	136
BN 23 89 50.....	30	BN 53 43 62.....	96	BN 57 34 55.....	138
BN 23 90 02.....	30	BN 53 43 63.....	96	BN 57 34 56.....	138
BN 29 36 50.....	19	BN 53 43 64.....	96	BN 57 34 58.....	136
BN 29 37 50.....	19	BN 53 77 82.....	92	BN 57 34 59.....	140
BN 29 38 00.....	34	BN 53 77 84.....	92	BN 57 35 02.....	117
BN 29 39 00.....	34	BN 53 77 86.....	92	BN 57 36 09.....	132
BN 29 40 00.....	34	BN 54 13 17.....	35	BN 57 36 13.....	128
BN 29 63 00.....	18	BN 54 13 18.....	35	BN 57 36 16.....	119
BN 29 64 00.....	32	BN 54 13 20.....	35	BN 57 36 26.....	112
BN 29 66 50.....	17	BN 54 13 28.....	35	BN 57 36 27.....	112
BN 29 97 50.....	19	BN 54 13 34.....	35	BN 57 36 28.....	112
BN 39 33 70.....	32	BN 54 13 35.....	35	BN 57 36 29.....	112
BN 41 94 00.....	18	BN 54 13 36.....	35	BN 57 36 30.....	120
BN 41 94 00.....	30	BN 54 13 38.....	35	BN 57 36 31.....	120
BN 42 01 00.....	18	BN 54 13 43.....	35	BN 57 36 32.....	120
BN 42 01 00.....	30	BN 54 13 88.....	35	BN 57 36 33.....	120
BN 45 09 40.....	18	BN 55 71 10.....	16	BN 57 36 40.....	110
BN 45 09 95.....	30	BN 55 71 11.....	16	BN 57 36 41.....	110
BN 52 71 82.....	16	BN 55 71 50.....	16	BN 57 36 42.....	110
BN 52 71 91.....	16	BN 55 71 51.....	16	BN 57 36 43.....	110
BN 52 77 57.....	90	BN 55 71 52.....	28	BN 57 36 50.....	124
BN 52 86 22.....	95	BN 55 71 53.....	28	BN 57 36 51.....	124
BN 52 86 24.....	95	BN 55 71 61.....	16	BN 57 36 52.....	126
BN 52 86 26.....	95	BN 55 71 63.....	28	BN 57 36 53.....	126
BN 52 86 27.....	95	BN 55 71 71.....	16	BN 57 36 59.....	118
BN 53 12 21.....	90	BN 55 71 73.....	28	BN 57 36 62.....	132
BN 53 12 25.....	90	BN 57 01 56.....	11	BN 57 36 63.....	130
BN 53 15 92.....	78	BN 57 29 24.....	116	BN 57 36 64.....	130
BN 53 17 12.....	90	BN 57 30 45.....	86	BN 57 36 84.....	128
BN 53 17 27.....	90	BN 57 31 89.....	114	BN 61 63 13.....	106
BN 53 38 43.....	36	BN 57 31 91.....	114	BN 61 63 14.....	106

<b>Bestell-Nr. Part-No.</b>	<b>Seite Page</b>
BN 61 63 31.....	103
BN 61 63 95.....	103
BN 61 63 96.....	105
BN 61 63 98.....	105
BN 61 64 30.....	104
BN 61 64 31.....	104
BN 61 64 39.....	103
BN 65 43 18.....	25
BN 65 56 40.....	25
BN 65 56 42.....	26
BN 65 56 43.....	26
BN 65 56 44.....	26
BN 65 56 60.....	26
BN 65 56 63.....	27
BN 65 56 73.....	27
BN 70 67 18.....	14
BN 70 67 40.....	14
BN 70 67 42.....	14
BN 70 67 43.....	14
BN 70 67 44.....	15
BN 70 67 60.....	15
BN 70 82 50.....	19
BN 71 03 39.....	22
BN 71 03 59.....	23
BN 71 03 68.....	24
BN 71 03 89.....	24
BN 72 12 80.....	17
BN 72 12 83.....	17
BN 72 58 10.....	34
BN 72 59 10.....	34
BN 72 60 10.....	34
BN 74 14 45.....	23
BN 74 14 60.....	22
BN 74 51 44.....	94
BN 74 51 46.....	94
BN 74 51 50.....	98
BN 74 51 52.....	98
BN 74 51 53.....	98

<b>Bestell-Nr. Part-No.</b>	<b>Seite Page</b>
BN 74 51 54.....	98
BN 74 53 80.....	97
BN 74 53 82.....	97
BN 74 53 83.....	97
BN 74 53 84.....	97
BN 74 75 44.....	12
BN 74 76 45.....	11
BN 75 33 48.....	84
BN 75 33 49.....	84
BN 75 33 52.....	84
BN 75 33 53.....	84
BN 75 33 54.....	84
BN 75 33 81.....	84
BN 75 33 82.....	84
BN 75 33 83.....	84
BN 75 33 84.....	84
BN 75 33 85.....	84
BN 75 33 86.....	84
BN 75 64 04.....	32
BN 75 64 30.....	100
BN 75 64 73.....	61
BN 75 64 74.....	61
BN 75 64 78.....	65
BN 75 64 86.....	100
BN 75 64 95.....	69
BN 75 64 98.....	74
BN 75 65 29.....	75
BN 75 78 55.....	11
BN 75 78 60.....	10
BN 76 64 03.....	65
BN 76 64 07.....	65
BN 76 64 13.....	65
BN 76 64 18.....	65
BN 76 64 19.....	61
BN 76 64 21.....	69
BN 76 64 22.....	69
BN 76 64 23.....	69
BN 80 64 00.....	69

<b>Bestell-Nr. Part-No.</b>	<b>Seite Page</b>
BN 80 65 00.....	32
BN 80 76 21.....	28
BN 80 76 25.....	28
BN 80 76 80.....	28
BN 80 77 06.....	28
BN 80 77 33.....	28
BN 80 77 50.....	28
BN 80 77 60.....	28
BN 80 77 88.....	28
BN 80 84 00.....	32
BN 81 82 42.....	82
BN 81 82 43.....	82
BN 81 82 44.....	82
BN 81 82 45.....	82
BN 81 82 46.....	82
BN 81 82 48.....	82
BN 81 82 57.....	78
BN 81 82 58.....	78
BN 81 82 61.....	78
BN 81 82 89.....	80
BN 81 82 90.....	80
BN 81 82 91.....	80
BN 81 82 99.....	82
BN 84 47 55.....	11
BN 84 47 60.....	10
BN 84 48 40.....	25
BN 84 48 42.....	26
BN 84 48 43.....	26
BN 84 48 44.....	26
BN 84 48 50.....	25
BN 84 48 51.....	25
BN 84 48 60.....	26
BN 84 48 63.....	27
BN 84 48 73.....	27
BN 84 55 55.....	11
BN 84 55 60.....	10
BN 84 60 57.....	11
BN 84 60 63.....	10

<b>Bestell-Nr. Part-No.</b>	<b>Seite Page</b>	<b>Bestell-Nr. Part-No.</b>	<b>Seite Page</b>	<b>Bestell-Nr. Part-No.</b>	<b>Seite Page</b>
BN 84 60 68.....	12	BN 95 08 80.....	57	BN J5 34 51.....	41
BN 84 60 69.....	12	BN 95 08 88.....	57	BN J5 34 52.....	41
BN 84 60 89.....	12	BN 95 18 20.....	28	BN J5 34 53.....	41
BN 84 63 18.....	14	BN 95 19 20.....	28	BN J5 36 38.....	41
BN 84 63 40.....	14	BN 95 45 10.....	31	BN J5 36 89.....	41
BN 84 63 42.....	14	BN 95 46 84.....	31	BN J5 37 41.....	41
BN 84 63 43.....	14	BN 95 47 16.....	31	BN J5 37 51.....	41
BN 84 63 44.....	15	BN 95 47 65.....	31	BN J5 37 62.....	41
BN 84 63 60.....	15	BN 98 29 00.....	18	BN J5 37 94.....	41
BN 84 73 39.....	22	BN 98 29 00.....	30	BN J5 37 95.....	41
BN 84 73 56.....	24	BN 98 29 11.....	18	BN J5 37 96.....	41
BN 84 73 59.....	23	BN 98 29 11.....	30	BN J5 37 97.....	41
BN 84 73 68.....	24	BN 99 88 00.....	18	BN J5 37 98.....	41
BN 84 73 69.....	23	BN A7 13 07.....	58	BN J5 38 24.....	41
BN 84 73 73.....	22	BN A7 13 08.....	58	BN J5 38 25.....	41
BN 84 73 89.....	24	BN A7 13 11.....	58	BN J5 38 26.....	41
BN 84 73 91.....	24	BN A7 13 13.....	58	BN J5 38 31.....	41
BN 85 43 18.....	25	BN A7 13 67.....	63	BN J5 38 34.....	41
BN 87 01 57.....	11	BN A7 22 45.....	69	BN J5 38 35.....	41
BN 87 01 63.....	10	BN A7 23 14.....	147	BN J5 38 36.....	41
BN 87 01 65.....	10	BN A7 23 15.....	147	BN J5 38 38.....	41
BN 87 01 67.....	12	BN A7 23 16.....	147	BN J5 39 60.....	41
BN 87 01 68.....	12	BN A7 23 17.....	147	BN J5 39 61.....	41
BN 87 01 69.....	12	BN A7 23 18.....	147	BN J5 40 13.....	41
BN 87 01 70.....	12	BN B0 77 87.....	104	BN J5 40 25.....	41
BN 87 01 73.....	10	BN B0 80 54.....	78	BN J5 40 58.....	41
BN 87 01 87.....	12	BN B0 80 57.....	78	BN J5 40 66.....	41
BN 87 01 89.....	12	BN B0 89 53.....	112	BN J5 40 72.....	41
BN 92 04 80.....	57	BN B0 89 53.....	120	BN J5 40 81.....	41
BN 92 24 50.....	17	BN B0 89 53.....	132	BN J5 42 83.....	41
BN 92 24 75.....	17	BN B0 89 62.....	105	BN J5 42 96.....	41
BN 92 25 50.....	17	BN B0 89 62.....	110	BN J5 43 23.....	41
BN 94 47 02.....	32	BN B0 94 99.....	82	BN J5 47 85.....	41
BN 94 49 50.....	19	BN J5 00 56.....	41	BN J5 51 87.....	41
BN 94 49 51.....	19	BN J5 33 88.....	41	BN J5 57 65.....	41
BN 94 50 60.....	17	BN J5 33 89.....	41	BN J5 58 56.....	41
BN 94 50 61.....	17	BN J5 33 91.....	41	BN J5 67 78.....	41
BN 95 08 15.....	100	BN J5 33 98.....	41		

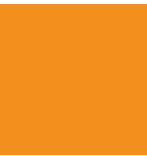

## SPINNER SALES OFFICES

### SPINNER AUSTRIA GMBH

Triester Str. 190

1230 Wien

#### AUSTRIA

tel.: +43 1 6627751 / fax: +43 1 662775115

officeaustria@spinner.de

### SPINNER Telecommunication Devices Co., Ltd.

351 Lian Yang Road

Songjiang Industrial Zone

Shanghai

201613 P.R. CHINA

tel.: +86 21 57745377 / fax: +86 21 57740962

salescn@spinner.de

### SPINNER Nordic AB, Branch Office

Ahventie 4 A214

02170 Espoo

#### FINLAND

tel.: +358 9 547 60220 / fax: +358 9 512 2144

sales.suomi@spinner.de

### SPINNER FRANCE S.A.R.L.

1, Place du Village

Parc des Barbanniers

92632 Gennevilliers Cedex

#### FRANCE

tel.: +33 1 41479600 / fax: +33 1 41479606

spinner-france@spinner.fr

### SPINNER ITALIA S.R.L.

Via De Carolis Nr. 44

40133 Bologna

#### ITALIA

tel.: +39 051 6194064 / fax: +39 051 6183689

spinner-italia@spinner.de

### SPINNER ELEKTROTECHNIK OOO

Kozhevniheskaja str. 1, bld. 1

Office 420

115114 Moscow

#### RUSSIAN Federation

tel.: + 7 495 644 0964 / fax: + 7 495 225 9300

f.kotcherguinski@spinner.de

### SPINNER ELECTROTÉCNICA S.L.

c/ Perú, 4 – Local nº 15

28230 Las Rozas (MADRID)

#### SPAIN

tel.: +34 91 6305 842 / fax: +34 91 6305 838

iker.llona@spinner.de

### SPINNER Nordic AB

Kråketorpsgatan 20

43153 Mölndal

#### SWEDEN

tel.: +46 31 7061670 / fax: +46 31 7061679

sales@spinner.se

### SPINNER UNITED KINGDOM Ltd.

Suite 8 Phoenix House

Golborne Enterprise Park, High Street

Golborne, Warrington

WA3 3DP

#### UNITED KINGDOM

tel.: +44 1924 275222 / fax: +44 1924 275221

salesuk@spinner.de

### SPINNER ATLANTA, Inc.

4355 International Blvd.

Suite 200

Norcross, GA 30093

#### USA

tel.: +1 770 2636326 / fax: +1 770 2636329

sales@spinneratl.com

www.spinneratl.com

### SPINNER GMBH • HEADQUARTERS

Erzgiessereistr. 33 • 80335 München • Germany

tel.: +49 (0) 89 12601-0 • fax: +49 (0) 89 12601-1292 • www.spinner.de

Abbildungen unverbindlich • Konstruktionsänderungen vorbehalten

Figures not binding • Designs subject to modification



Zertifiziert nach DIN EN ISO 9001/14001  
in Design/Entwicklung,  
Produktion, Montage, Wartung  
Umweltmanagement