

Brief on
Yangtze Optical Fibre and Cable Co. Ltd.

2009

Foundation of YOFC



**Changjiang
Communications**

25%

China Telecom

37.5%

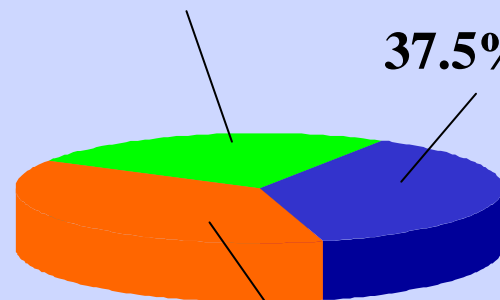

Draka Comteq

37.5%

Established in May 1988 and released production in June 1991.

Owns the capacity to produce preform, fibre and cable and is the largest fibre and cable JV in China.

Structure of share

China MPT
25%

Wuhan Credit and Investment Co.
25%

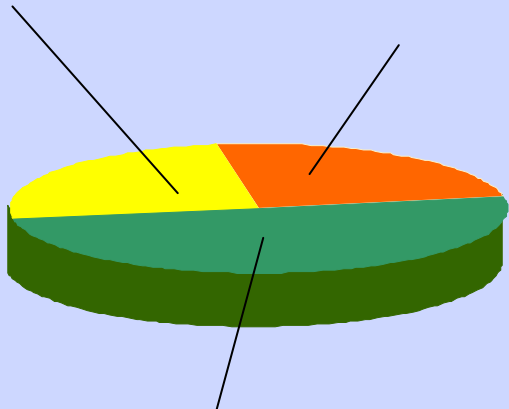

Netherlands Philips 50%

1988

Wuhan Yangtze Communication Industry Group
25%

China Telecom (China Huaxin PT Economic Development Center)
37.5%

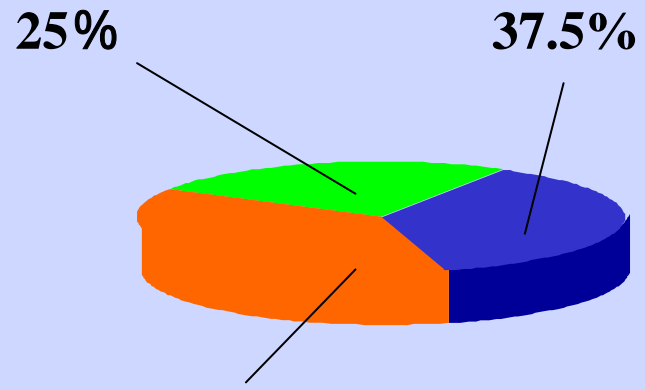

Netherlands Draka Comteq 37.5%

since 1996



长飞光纤光缆有限公司
YANGTZE OPTICAL FIBRE AND CABLE COMPANY LTD.



The professional optical fibre and cable manufacturing and R&D corporation with the complete array of products, advanced technologies, and larger production scale in China

Company of the world class

- **The 2nd largest fibre manufacturer in the world**
- **The 5th largest cable manufacturer in the world**
- **The largest fibre and cable manufacturer in China**
- **Possesses the technologies and the products of the world class**
- **Ranked No. 1 in terms of sales for 17 consecutive years in China**
- **The largest supplier for all top telecom operators in China**

High quality human resources

Education

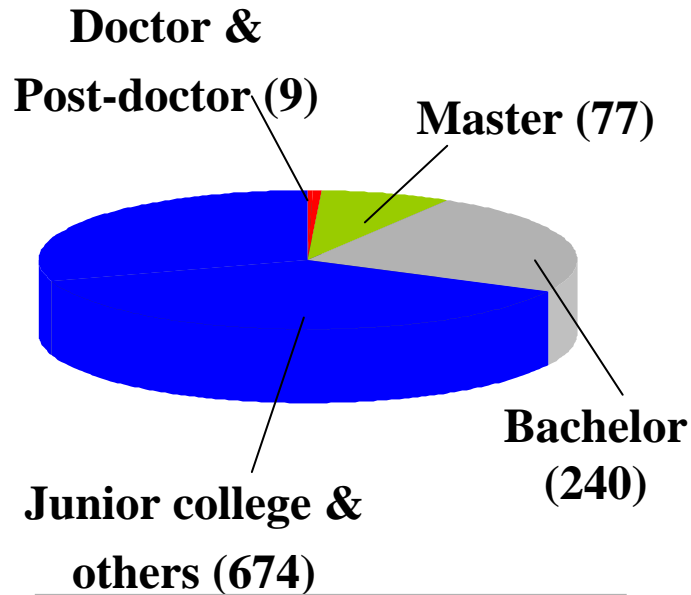

Total staff: 1000

Position

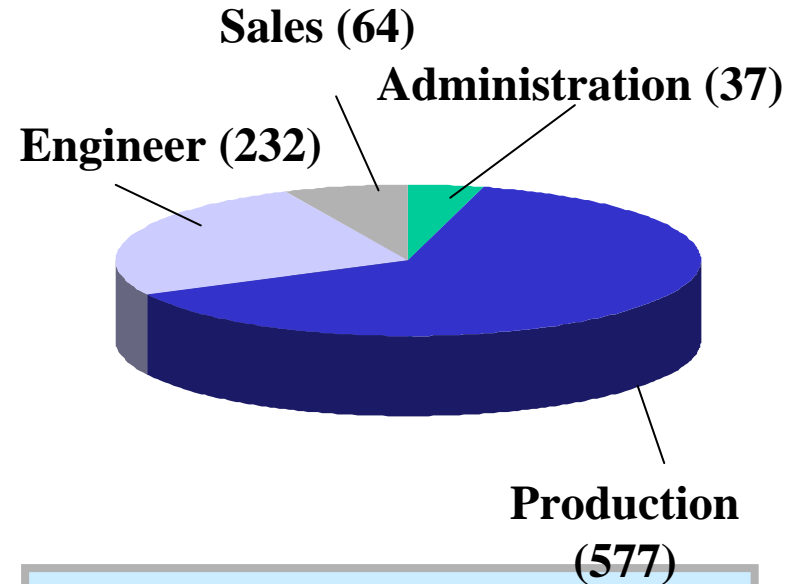

Production value per person:
RMB 2 mil/USD300,000.00,
ranking No. 1 in the same
sector in China

Advanced management system

ORACLE ERP: sales, plan, materials, production, transport, finance

Overall management systems: ISO9001/14001/17799

OHSAS18000

Production assistant system

Automatic warehouse: the only one in the same sector in China

Knowledge management system

Overall promises to customers

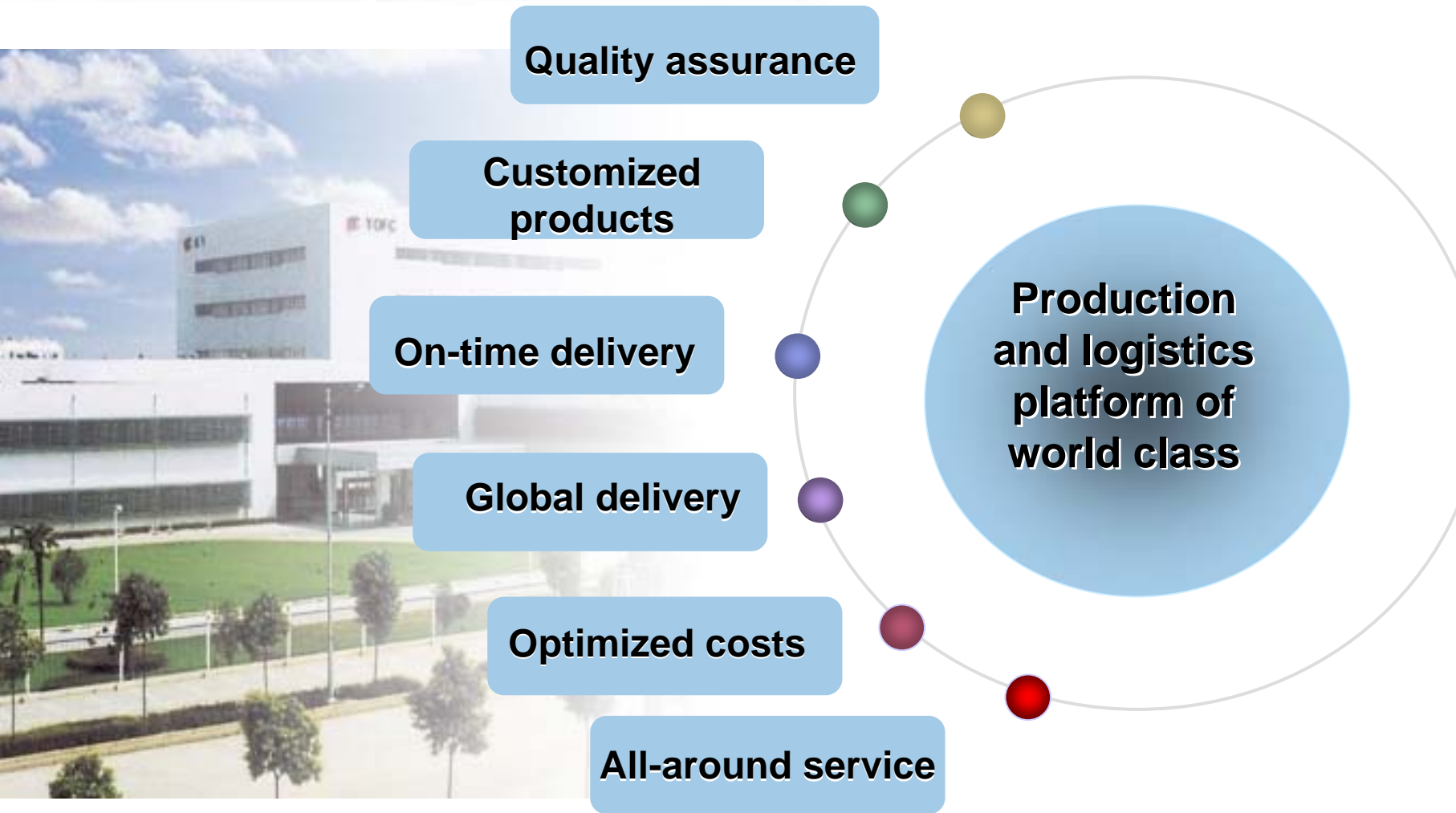

Large-scale production capacity

Preform: 700 ton
70% of the preform
consumption in China



Fibre: 20 mil km



Cable: 0.3 mil sheath-km,
equaling 8 mil fibre-km

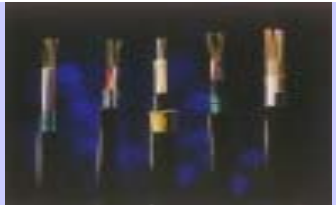

Large production capacity



the most advanced manufacturing equipment to ensure the high quality of products

Products family

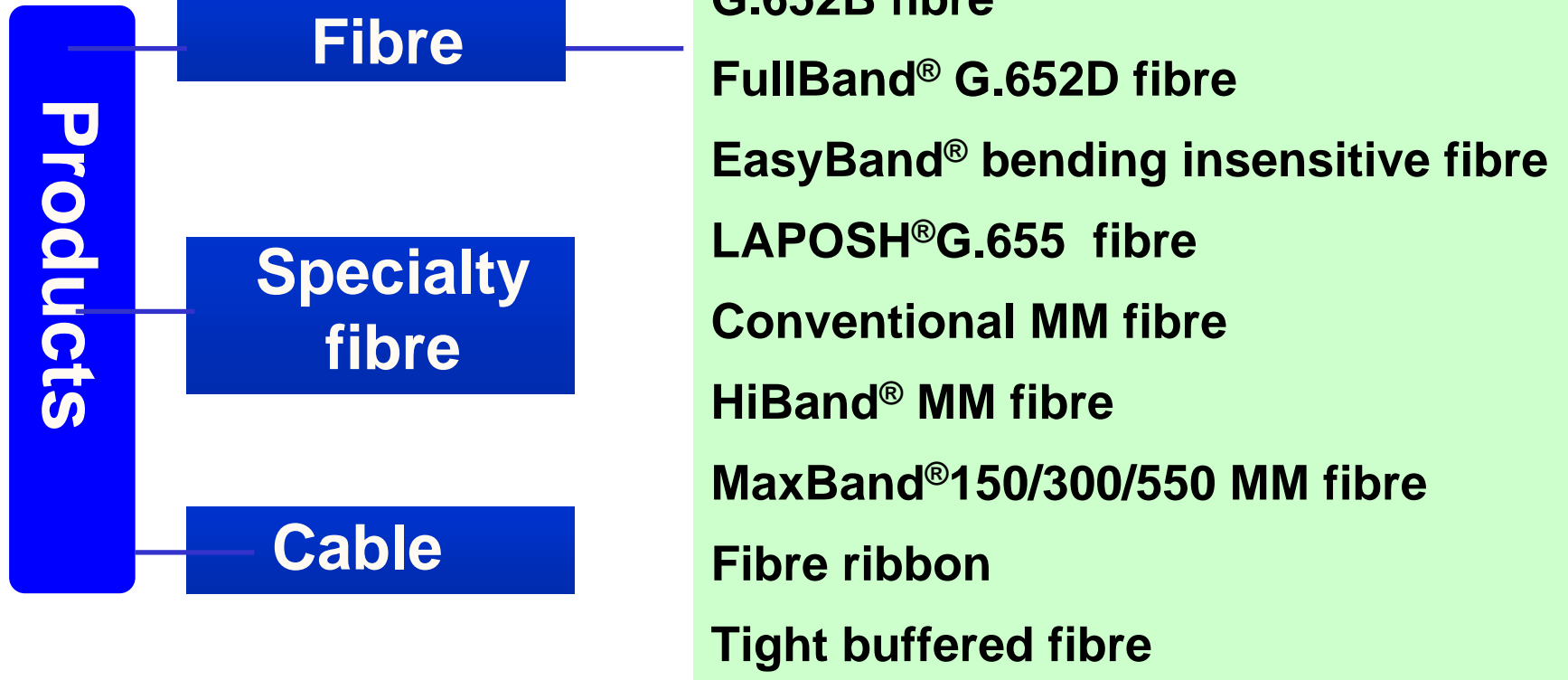

Products family

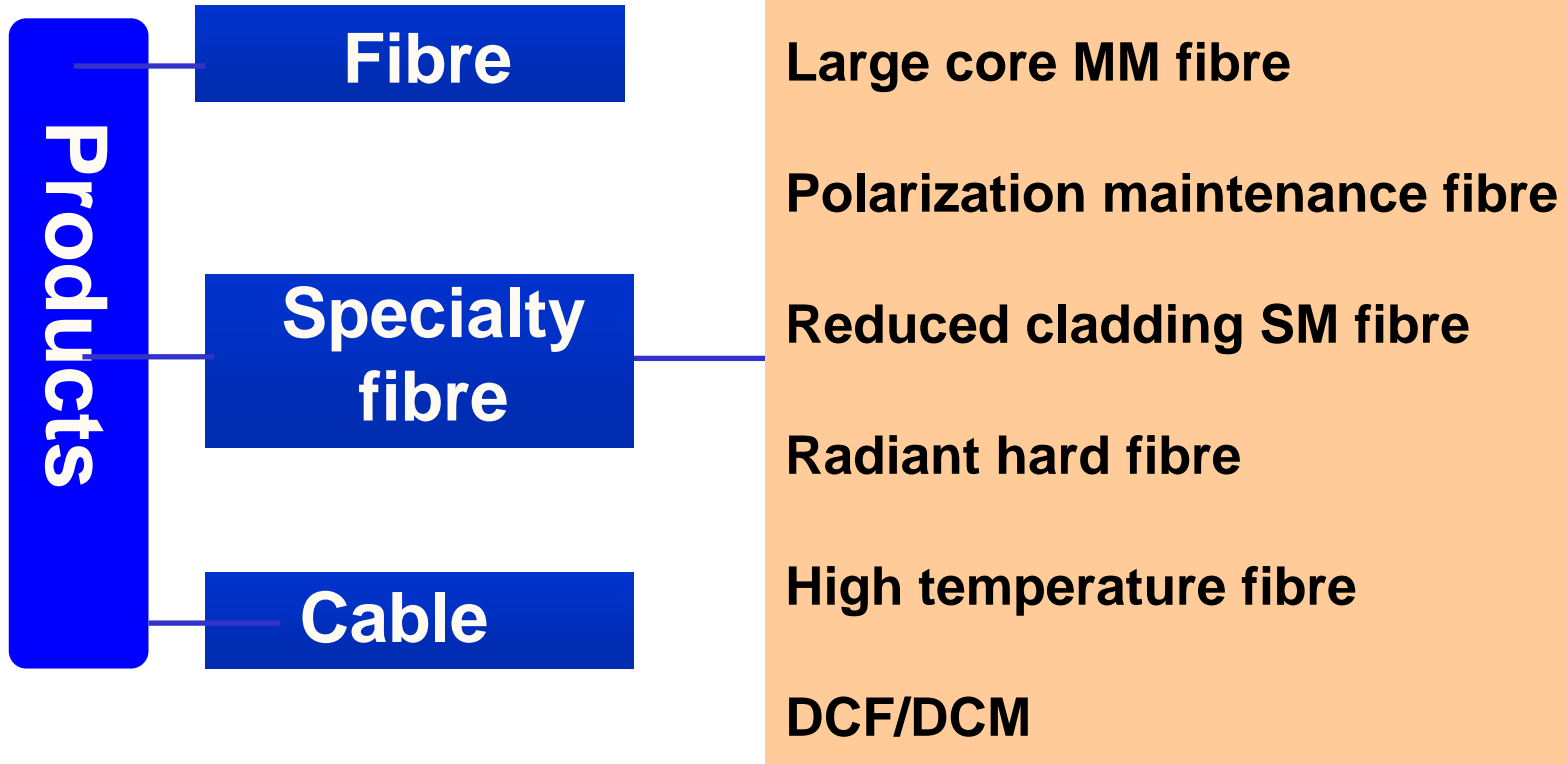

Products family

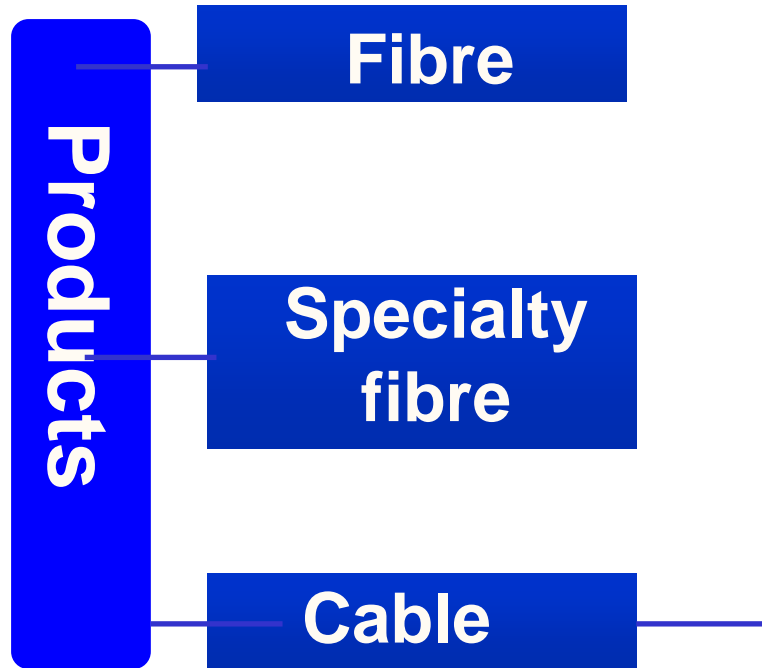

Loose tube stranded cable

Unitube cable

Slotted core ribbon cable

Termite/rat-proof cable

flame-retardant cable

ADSS

Nonmetallic cable

Sewer cable

Surface inlaid cable

Miniature figure 8 cable

Indoor cable

Chinese Sales and Service



Global Sales and Service

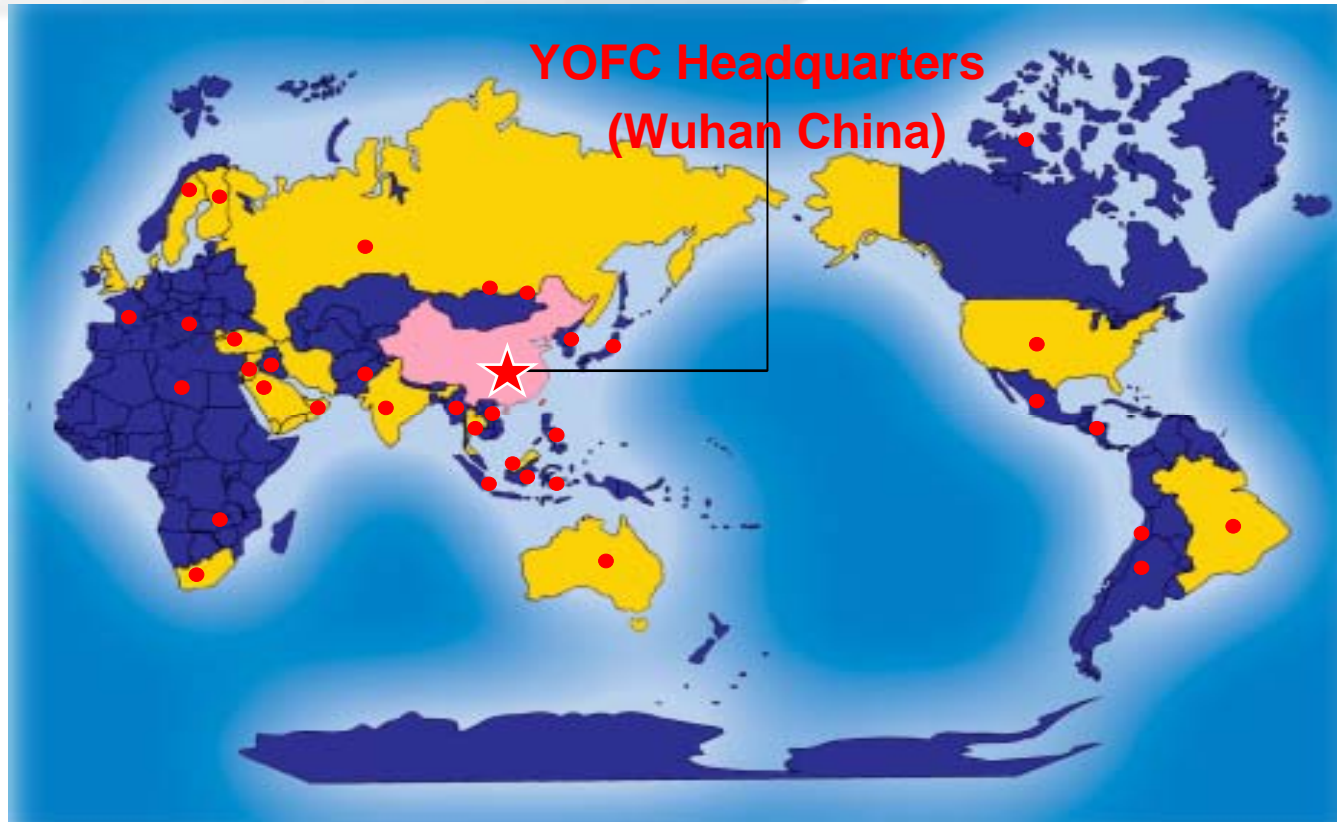

More than 50 countries, such as USA, Germany, Italy, Australia, the Netherlands, Sweden, Japan, S. Korea, India, Thailand, Syria, Pakistan, Turkey, Iran, UAE, Brazil, South Africa, Nigeria, etc.

Major fibre customers



Almost all the domestic cable manufacturers and some telecom equipment manufacturers

Optical fibre customers

All the cable manufacturers in China

Some telecom equipment manufacturers in China

Specialty fibre customers such as aviation in China

Cable manufacturers in more than 20 countries

Major cable customers



Customers of all circles who demand cable

Optical cable customers

telecom operators

The customers in the other industries

Special cable customers

Achievements

In 2008, YOFC reached a milestone of sales :

Produced and sold over 17 million f-km of fibres

Produced and sold cable 250 thousand sheath-km of cables

By the end of 2008 , YOFC has totally produced and sold :

Over 70 million f-km of fibres

Of which 13 million f-km of fibres have been exported

The only preform supplier of China

Market share in China

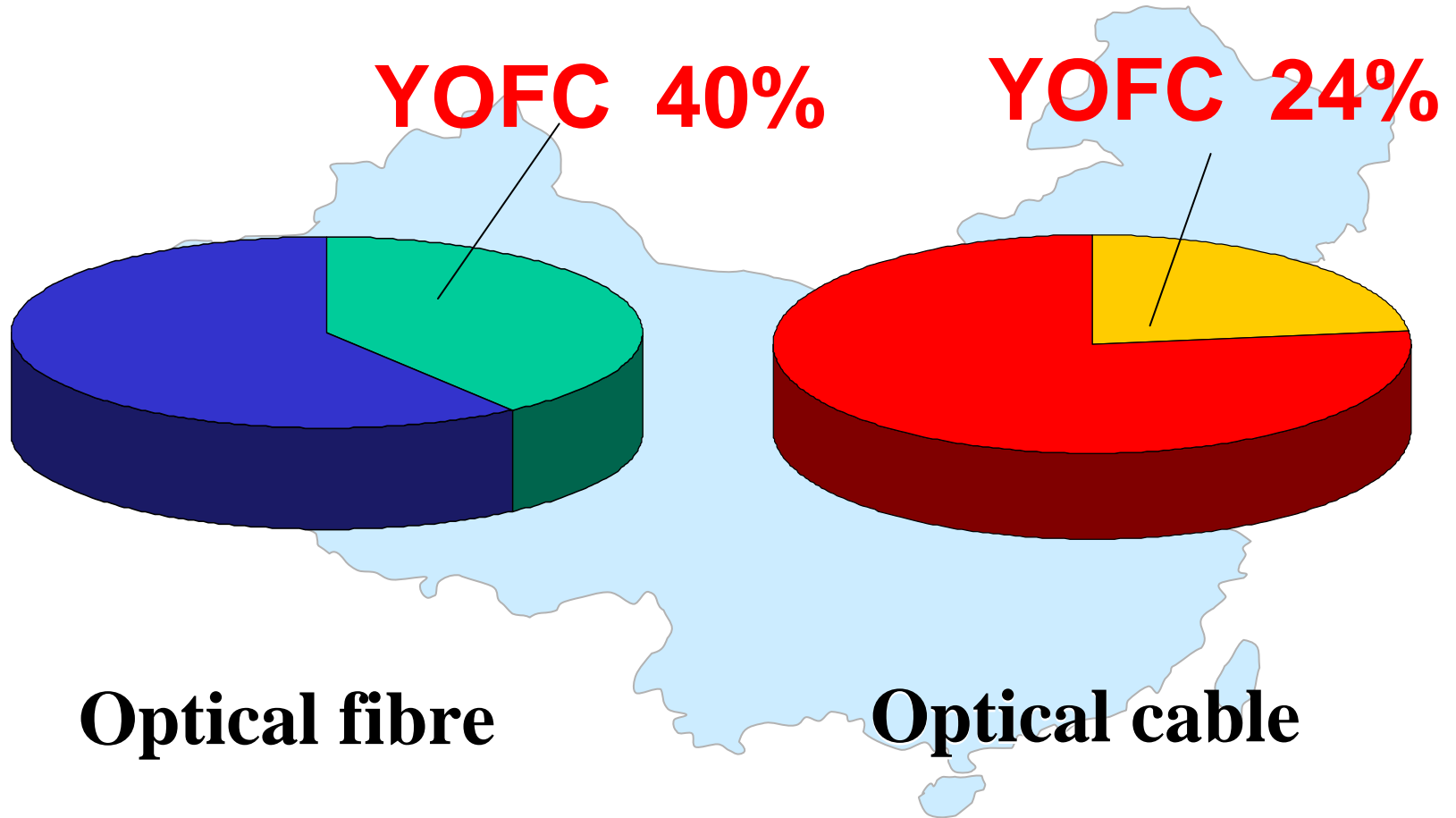

Data : market report

The development of YOFC'S market share in China

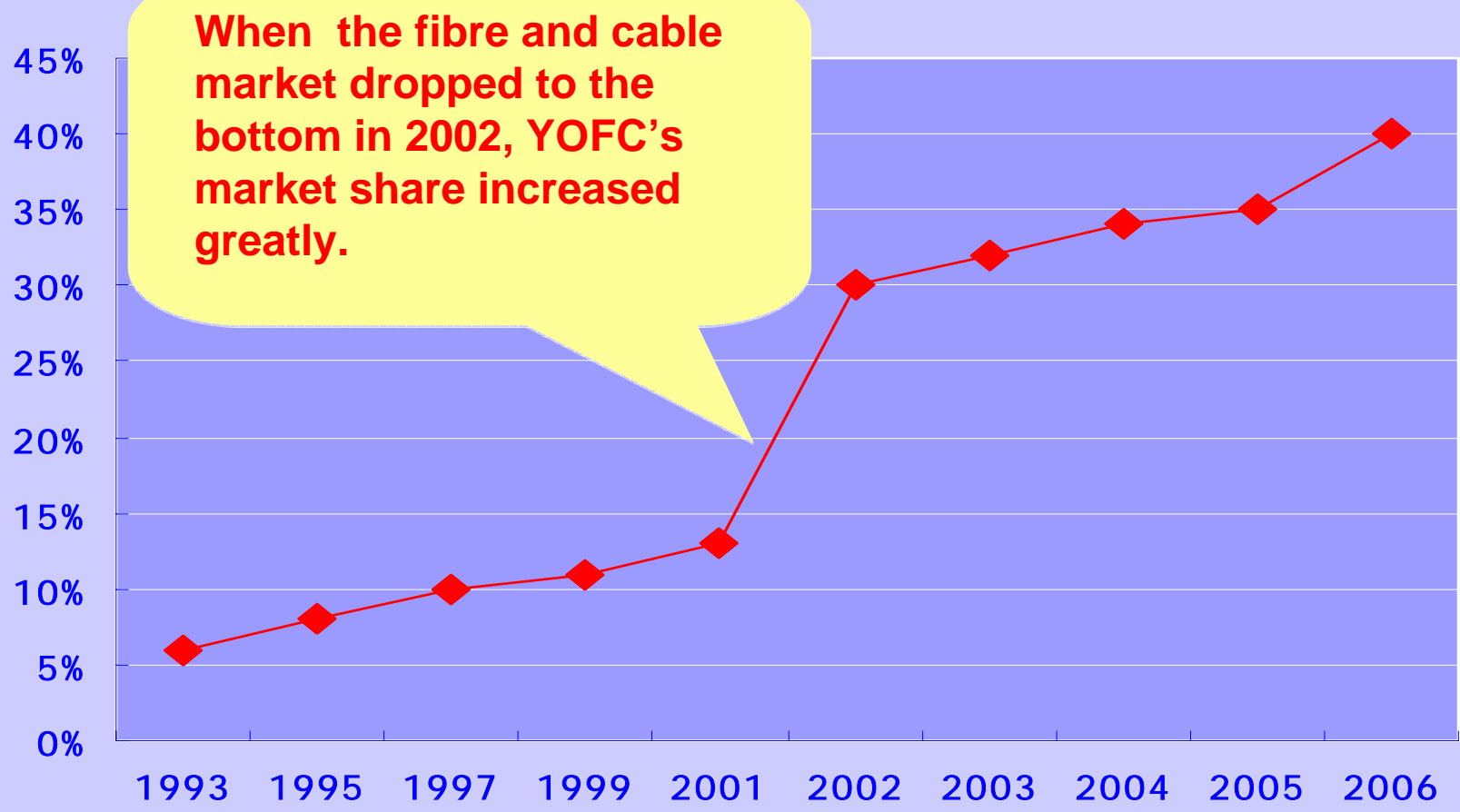

Domestic optical fibre market

Investment



HYC (5.55%)



NKW (20%)



ZFOC (10%)



CFSL (9.64%)



YOFC (51%)



AoX (42%)

长飞光纤光缆有限公司



YOFC (75%)

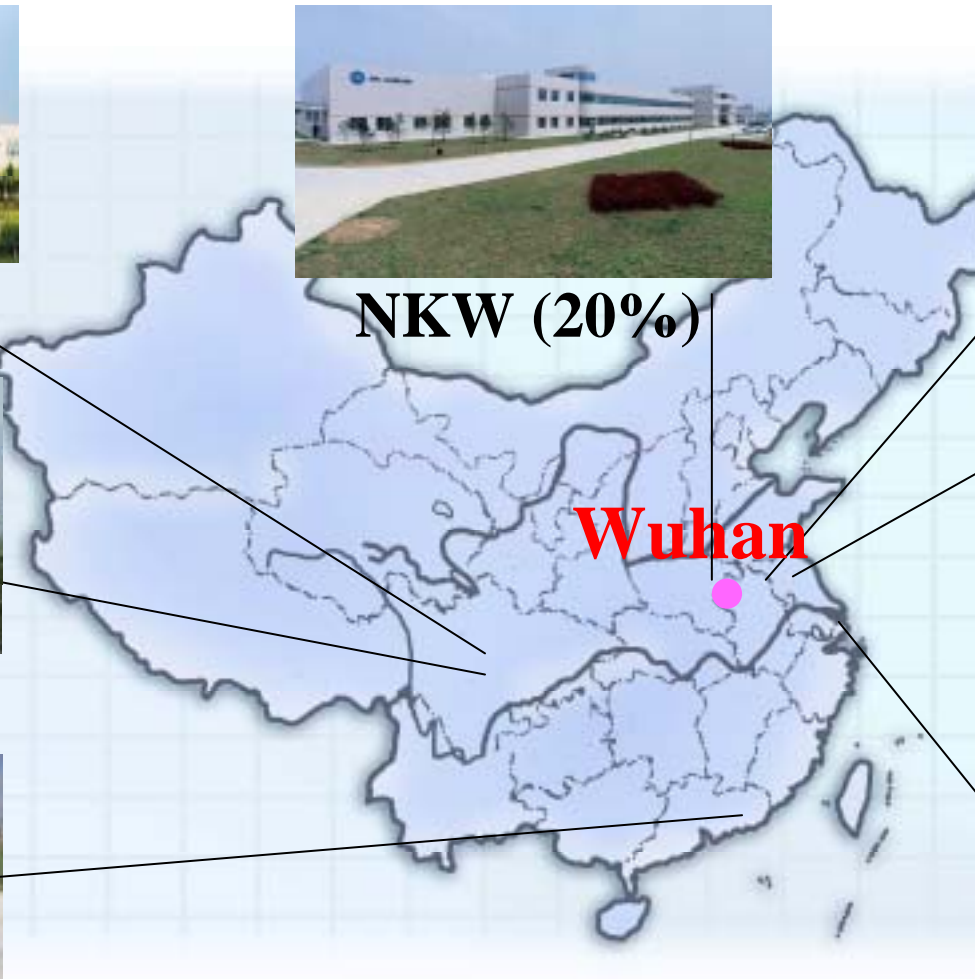

Continual technical innovation and cooperation

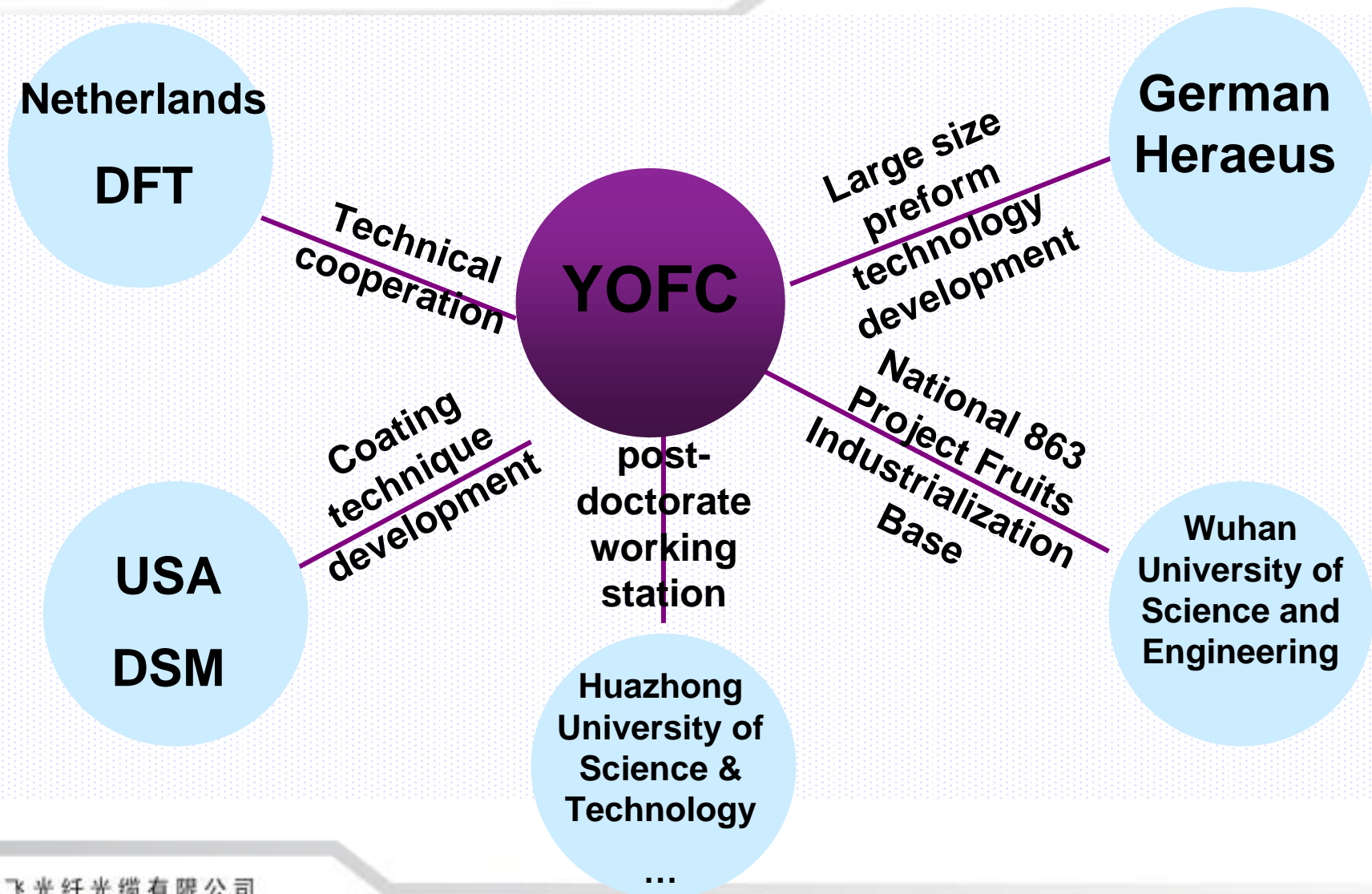

Core technology and IPR

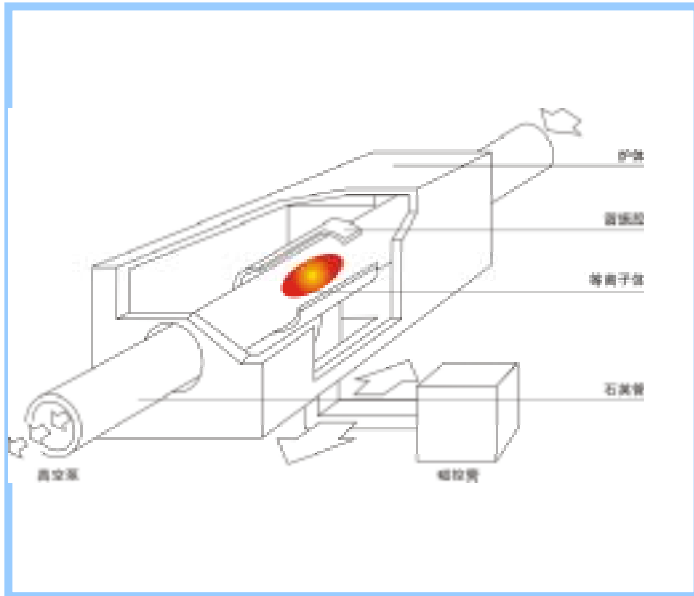

Over 100 granted patents
Over 40 invention patents
Several granted patents
in USA

YOFC owns many core technology
such as PCVD

Impressive honor



In 2005, “Study on Non-zero Dispersion Shifted Single-mode Fibre Made by PCVD and Industrialized Production” was awarded the second prize of national science and technology advancement.

This is the highest honor won in the same sector in China and YOFC is only and the first optical fibre and cable manufacturer that has won such honor.

Strategic objective and mission

Strategic objective:

Become the most influential fibre and cable manufacturer in the world and maintain the leading position in the global fibre and cable sector.

Task:

Promote the wide application of fibre in China and in the world and let everyone enjoy the freedom and happiness brought by fibre.

Bright prospects

In the 20-years development course , taking “Customers’ Satisfication” as its task, YOFC has established strategic partnership with customers and realized the co-development and the win-win situation.

Facing the continually increasing demand in the worldwide optical communications market, YOFC is standing at the forefront of China’s optical fibre and cable industry and is preparing for a new round of growth.



Thanks